

CENTURY[®]

Heavy Duty Integrated



4024 - 9055

20 TON

50 TON



AWDIRECT

Zips.com | 800-222-6047



SETTING THE STAN



4024

- Over 103" of Underlift Reach
- 20-Ton Recovery Boom
- 20,000 lb. Winches
- Single-Axle Unit
- Great Value Loaded with Features



5130

- 128" of Underlift Reach
- 25-Ton Recovery Boom
- Our Largest Single-Axle Unit
- 25,000 lb. Winches
- Best In Class Weight Rating



5230

- 128" of Underlift Reach
- 30-Ton Recovery Boom
- Weight-saving Aluminum Body Option
- 25,000 lb. Winches
- Incredibly Versatile Loaded with Features



7035

(PolyBilt Body Option shown)

- 128" of Underlift Reach
- 35-Ton Recovery Boom
- Dual 35,000 lb. Winches
- Our Most Popular Heavy-Duty Unit
- Optional Lightweight PolyBilt Body



9055

- 138" of Underlift Reach
- 50-Ton 3-Stage Recovery Boom
- Dual 50,000 lb. Winches
- Our Largest Capacity Integrated Unit Perfect for Mixers, Packers, Busses & Everything In Between



SP 850-XP

- Hydraulic Pivoting Stiff Legs
- Add Additional 35,000 lb. Winches
- Available on the 7035 and 9055
- Perfect for Tough Recovery Situations
- Finest European Technology

Above units show several popular body and equipment options.

STANDARD IN HEAVY-DUTY TOWING & RECOVERY

Optional Underlifts for the 7035 and 9055 with capacities up to 55,000 lbs. Retracted.

Available Winch Capacities:

4024	(2) 20,000 lbs.
5130	(2) 25,000 lbs.
5230	(2) 25,000 lbs.
7035	(2) 35,000 lbs.
9055	(2) 50,000 lbs.

Variety of Available Lighting Configurations

Optional Aluminum Tubular Pylon Available in Several Styles and Sizes.



Optional Rear Outriggers with Hydraulic Extendable Feet and Flip Down Rear Spade for Added Stability.



Standard Dual Rear Control Stations

- Dual Pressure Gauges (driver side)
- Air Winch Clutch Release Switches
- Driver Side Hour Meter and Air Regulators
- Optional LED Backlit Control Legends



The largest choice of standard and optional forks and attachments in the industry:

- 9 Sets of Cast Forks
- Pivoting Spring Lift Adaptors
- Chain Hook End Cups
- Low Profile Cast Forks Holders



Aluminum Modular Body

- Industry leading storage space
- Adjustable shelves with chain racks and fork holders
- Single button lock and unlock of compartments
- Key fob remote
- Optional 3 or 7 drawer tool box
- Optional fold down storage brackets for heavy duty tire lift

5230 Model Shown

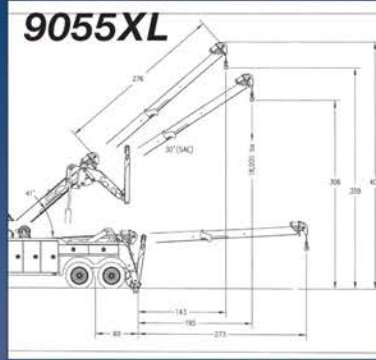
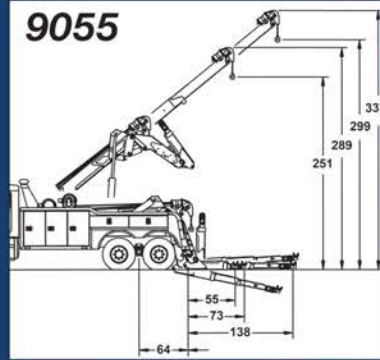
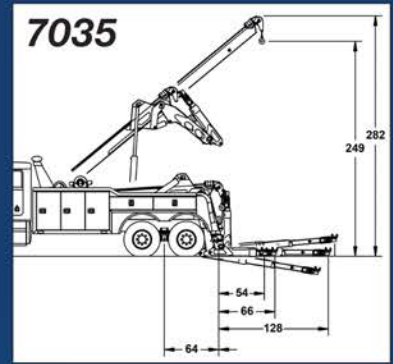
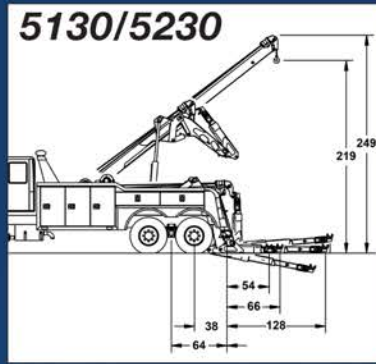
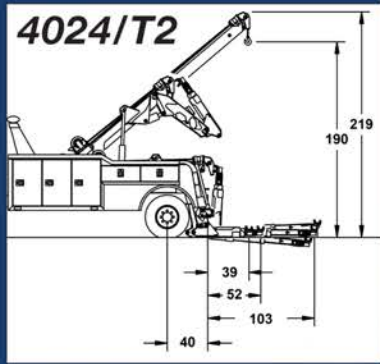

BODY SPECIFICATIONS		
Model	Standard Body Configuration	Additional Body Configurations
4024	138" C.A.	156, 182" C.A.
5130	156" C.A.	182", 206", 230" C.A.
5230	156" C.B.	180" / 204" C.B.
7035	156" C.B.	180" / 204" C.B.
9055	156" C.B.	180" / 204" C.B.
9055XL	180" C.B.	180" / 204" C.B.
SP 850-XP	156" C.B.	180"

Low Rider Underlift



Century offers the Low Rider Underlift to provide the strength and durability you need for your toughest tows while still providing the lowest profile stinger. The Low Rider provides you with 144" of reach while the "Coach" Low Rider provides additional reach up to 160" to haul those difficult pumpers, packers, coaches, and fire trucks.

Standard Length Body Configuration

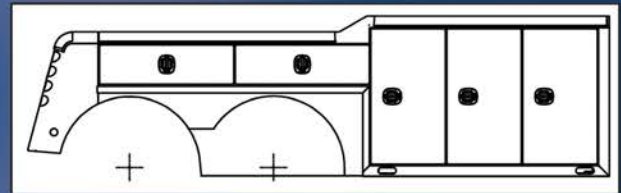

Century offers multiple body configurations for the Heavy Duty Integrated series to help better fit your demands and suit your individual needs.

CENTURY®

PolyBilt Body Option



The PolyBilt body option provides a rugged durable design that has gone through years of field testing. The boxes feature roll up aluminum doors with remote lock/unlock, adjustable shelves and built in storage for your forks and popular attachments. The PolyBilt body is ideal for harsh environments to provide superior protection from rust and corrosion caused by road chemicals.

BOOM SPECIFICATIONS

Model	Boom Structural Rating (S.A.E.)		Boom Angle	Max Hook Height (in)	Hydraulic Boom Extension (in)
	Retracted 30°	Extended 30°			
4024	20 ton	15,000 lbs.	40°	190"	96"
5130	25 ton	16,000 lbs.	39°	219"	120"
5230	30 ton	16,000 lbs.	39°	219"	120"
7035	35 ton	22,000 lbs.	40°	249"	130"
9055	50 ton	30,000 lbs.	39°	259"	144"
9055 (3 Stage)	50 ton	18,000 lbs.	39°	299"	216"
9055XL	50 ton	18,000 lbs.	39°	359"	276"

WINCH SPECIFICATIONS

Model	Winch Capacity	Winch Type	Cable Specifications
4024	20,000 lbs.	Dual Planetary Winch	9/16" x 175' I.W.R.C.
5130	25,000 lbs.	Dual Planetary Winch (2 Speed)	5/8" x 200' I.W.R.C.
5230	25,000 lbs.	Dual Planetary Winch (2 Speed)	5/8" x 200' I.W.R.C.
7035	35,000 lbs.	Dual Planetary Winch (2 Speed)	3/4" x 200' I.W.R.C.
9055	50,000 lbs.	Dual Planetary Winch (2 Speed)	3/4" x 250' I.W.R.C.
SP 850-XP	35,000 lbs.	Dual Planetary Winch (2 Speed)	5/8" x 200' I.W.R.C.

UNDERLIFT SPECIFICATIONS

Model	Extended Underlift	Retracted Underlift	Tilt Arc	Tow Rating
4024	12,000 lbs. @ 103"	24,000 lbs. @ 39"	8°	50,000 lbs.
5130 / 5230	16,000 lbs @ 128"	35,000 lbs. @ 54"	20°	80,000 lbs.
7035*	16,000 lbs @ 128"	35,000 lbs. @ 54"	20°	80,000 lbs.
7035 Coach Low Rider	16,000 lbs. @ 138"	35,000 lbs. @ 59"	20°	80,000 lbs.
9055*	17,000 lbs. @ 138"	55,000 lbs. @ 55"	17°	80,000 lbs.
9055 Coach Low Rider	18,000 lbs. @ 160"	55,000 lbs. @ 62"	17°	80,000 lbs.

*Based on a 42" chassis frame height. Retracted distance taken with fork holders flipped inward
Measurement & Specifications include the Optional "Street" Lowrider

CHASSIS RECOMMENDATIONS

Model	Front Axle (lbs.)	Rear Axle (lbs.)	Clear C.A. / C.B.	After Frame from Center of Rear Axle	R.B.M. (in./lbs.)
4024	10,000	21,000	138"	42"	1,200,000
5130	12,000	21,000	156"	40"	1,650,000
5230	13,200	40,000	156"	40"	2,250,000
7035	13,200	40,000	156"	40"	2,250,000
7035 (SP 850-XP)	14,600	40,000	204"	40"	3,500,000
9055	14,600	40,000	156"	40"	3,000,000
9055 (SP 850-XP)	20,000	40,000	204"	40"	3,500,000
9055XL	16,000	46,000	180"	40"	3,500,000

Standard Features

- Dual Control Stations
- Pressure Gauges & Hour Meter
- Hydraulic Pump
- Diagonal Hydraulic Rear Spades w/Flipper Feet
- Safety Chains in Rear Pockets with Roller
- Quick Connect Air & Electric Hook Ups
- MVEC Power Distribution System & Switch Panel
- MMO Interface (7035/9055 only)
- Tailboard D-Rings
- Low Pull "D" Ring Kit
- Flipper Feet Grater Blades
- "D" Rings (Tailboard Mount, Std on 7035 & 9055)
- LowRider Underlift (7035 & 9055)
- Upgrade to 7035 Underlift (5230)

Boom Features

- Power Elevation & Power Extension
- 360° Sheave Head
- Cable Tie Backs
- Cable Tensioners
- Winch Air Free Spool
- Dual 2-Speed Planetary Winches (N/A for 4024)

Underlift Features

- Power Tilt & Power Extension
- Hydraulic Fold
- 3-Stage Design
- Low Profile 70° Pivoting Heavy Duty Fabricated Cross Bar
- Low Profile Fork Holders
- Pivoting Spring Lift Adaptors
- Chain Hook End Caps
- 14 FXN Wireless Remote Control with Charging/Docking Station (7035/9055 only) (8 FXN on 4024/5130/5230)
- 9 Sets of Cast Steel Forks:

3" Short	4.5" Short	Grab Axle Fork
3" Medium	4.5" Medium	6" Short Offset
3" Tall	4.5" Tall	6" Medium Rear Axle Fork

Body Features

- 96" Wide Aluminum Modular Body
- Rubber Mounting Isolators
- LED Body Lighting
- LED Tool Compartment Lighting
- Chrome Double Action Latches with Remote Lock/Unlock
- Gas Door Shocks
- Adjustable Shelves
- Lift Fork Storage
- Chain Storage
- Tailboard Fork & Chain Storage
- Aluminum Tread-Plate Walkway
- Mud Flaps

All ratings are based on structural factors only, not vehicle capacities or capabilities. Specifications shown are approximations and may vary depending on chassis selected. Miller Industries Towing Equipment Inc. reserves the right to change or modify product and or specifications without notice or obligation. Some equipment shown is optional.

*All Recommendations are minimums. Heavier specifications may be required depending on chassis and equipment weight.

The outside frame rails of chassis extending behind the cab must be free of fuel tanks, air tanks, battery boxes, etc.

Optional Features

- | | | | |
|---|---|--|---|
| <ul style="list-style-type: none"> • Air Shift PTO • Tailgate Underlift Controls • Additional Body Lengths • Crossover Tunnel Box • PolyBilt Body Option • MMO Interface (STD 7035/9055) • LED Body Strip Lamps • Body Lighting Strobe Kit • Stainless Dress-Up Kits • Aluminum Tubular Light Pylon • 3 and 7 Drawer Tool Boxes • Offset Fork Holder Extensions | <ul style="list-style-type: none"> • Fork Riser Brackets • Chain Hook Slide Adapter • Pintle Hook Attachment • 5th Wheel Plate • King Pin Attachment • Trailer Ball Adapter • Heavy Duty Tire Lift (13K) • XHD Tire Lift (25K) (7035,9055) • Tire Lift Storage Brackets • Chain Washdown Compartment • Additional Lift Forks • Ground Penetrating Plate | <ul style="list-style-type: none"> • Backlit Controls • Chain Package • Endless Loop Sling Package • Spreader Bars • Screw Pin Shackle Package • Snatch Blocks • Snatch Block Storage Bar or Rack • Light Bar • LED Work & Hook-Up Lighting • LED Swivel Work Lights • Coach LowRider Underlift (7035,9055) • PTO Override | <ul style="list-style-type: none"> • Wireless Wide Load Light Bar • Dual Rear Camera & Monitor • Hydraulic Extendable Rear Outriggers • 24" 30" 36" or 48" Saddle Tunnel Box • Shelf Kit for 30", 36" & 48" Tunnel Boxes • 9055-B (2-Stage Boom, 35K Winches, MMO Delete) |
|---|---|--|---|



Zips.com | 800-222-6047