

DewEze

CLUTCH PUMP KIT

710088	Bracket Assy. (Inc. item 1, 22)		Kit No.	700318
711097	Bracket Bolt Pkg. (Inc. items 5-8, 11, 15, 17)		Make	Dodge
None	Pulley Bolt Pkg.		Engine	5.9L
None	Idler Bolt Pkg.		Fuel	Diesel
None	Fan Spacer Bolt Pkg.		Year	1994-98
			Equipment	Turbo
			Revised	G 9-29-98

ITEM	PART #	DESCRIPTION		
1.	711096	Pump mounting bracket (Inc. item 16)	11.	OEM
2.	740242	Idler pulley/flat	13.	Shoulder bolt/OEM idler Bolt/tensioner
3.	*	Pump	14.	OEM
4.	740148	Clutch/serpentine	15.	110603
5.	110214	5/16NC x 5 Grade 8 bolt	16.	711099
6.	110487	M10 x 120 x 1.5 Bolt	17.	110224
7.	110544	7/16NC x 2 Bolt	18.	740241
8.	110213	Shoulder bolt/DewEze idler	19.	<i>a</i> 120075
9.	110425	3/8NC x 1 1/4 Bolt		<i>b</i> 720104
10.	110672	3/8 Lock washer	20.	<i>a</i> 720123
11.	110219	7/16NC Lock nut		<i>b</i> 120076
12.	OEM	M10 x 1.5 Nut	21.	711161
			22.	OEM

*a*For use with 5, 7, 9 gal. pump
*b*For use with 12, 17 gal. pump

* See Master List For Pump Part No.

FIG. 1

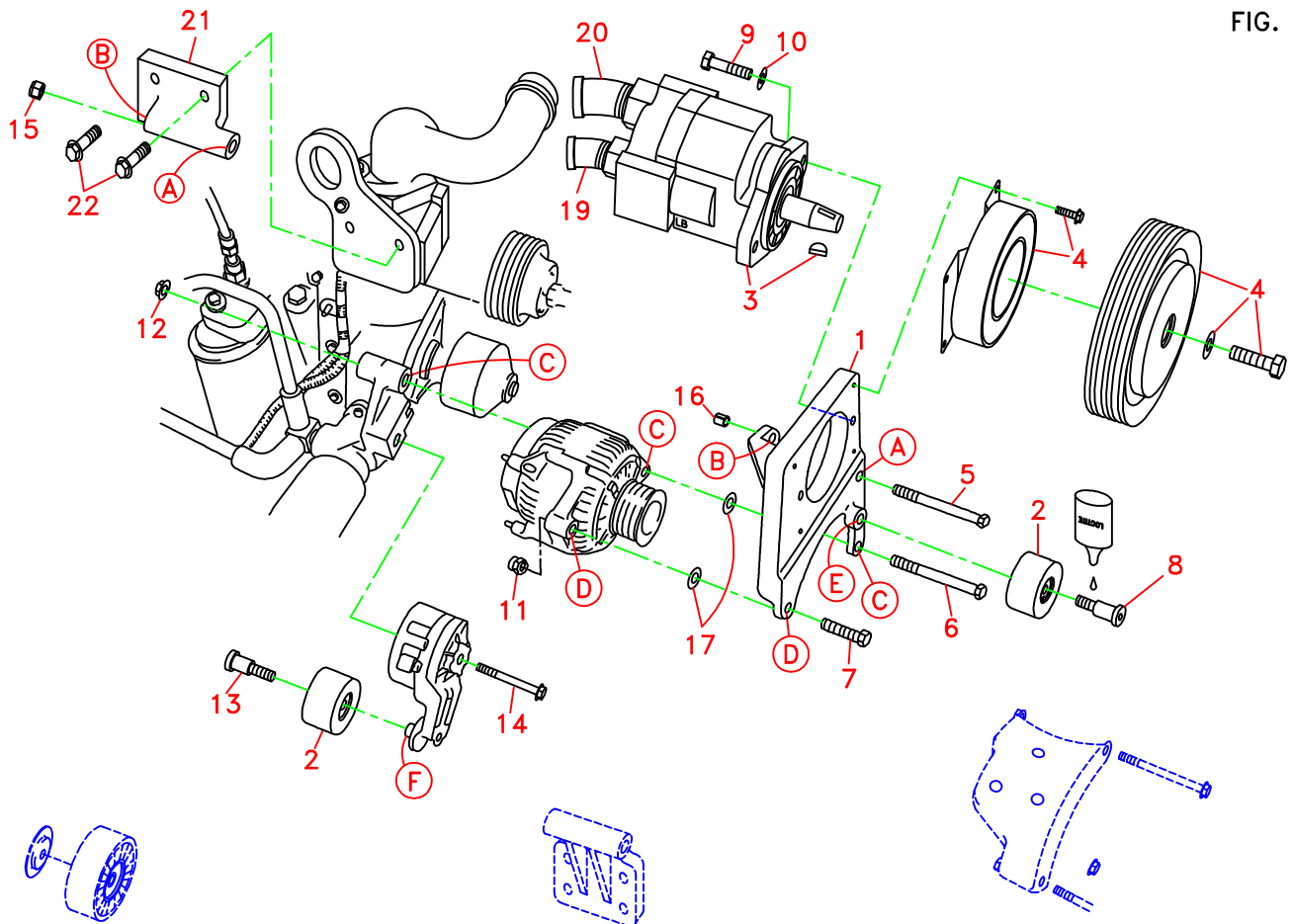

REMOVE OEM IDLER
PULLEY AND WASHER

REMOVE OEM BRACKET
FROM THERMOSTAT HOUSING

REMOVE OEM ALTERNATOR
BRACKET AND BOLTS

(A)(B)(C)... Denotes bolt holes in engine to locate corresponding holes in Pump Brkt.

FIG. 2

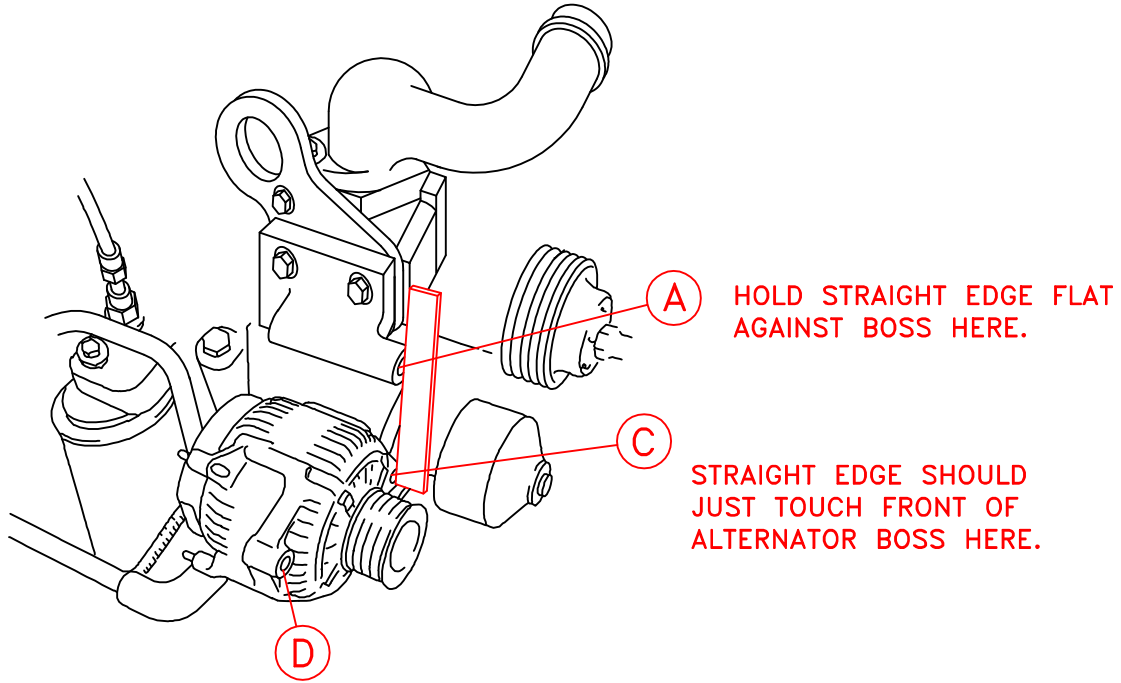

FIG. 3

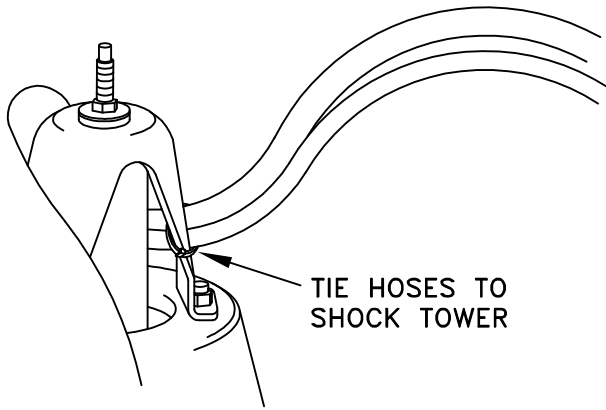

FIG. 4
BELT ROUTING

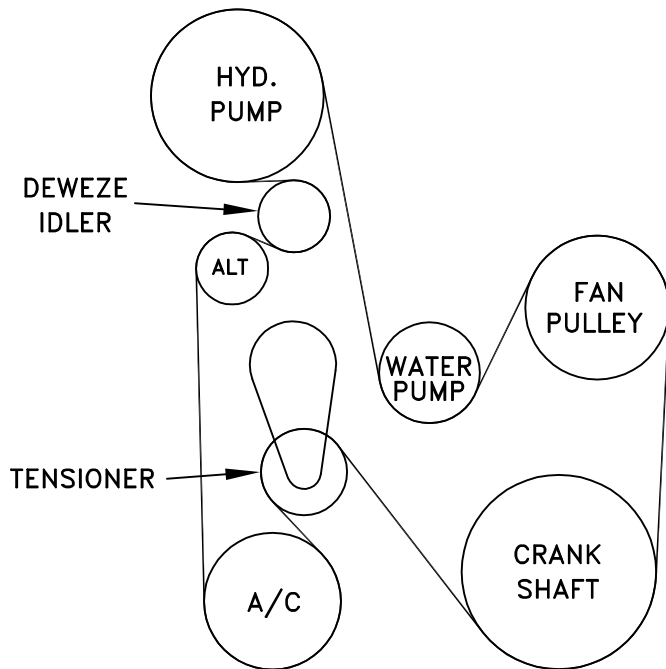

FIG. 7
OEM BELT TENSIONER

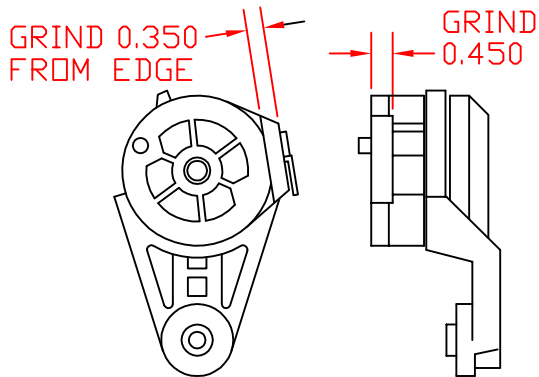

FIG. 5

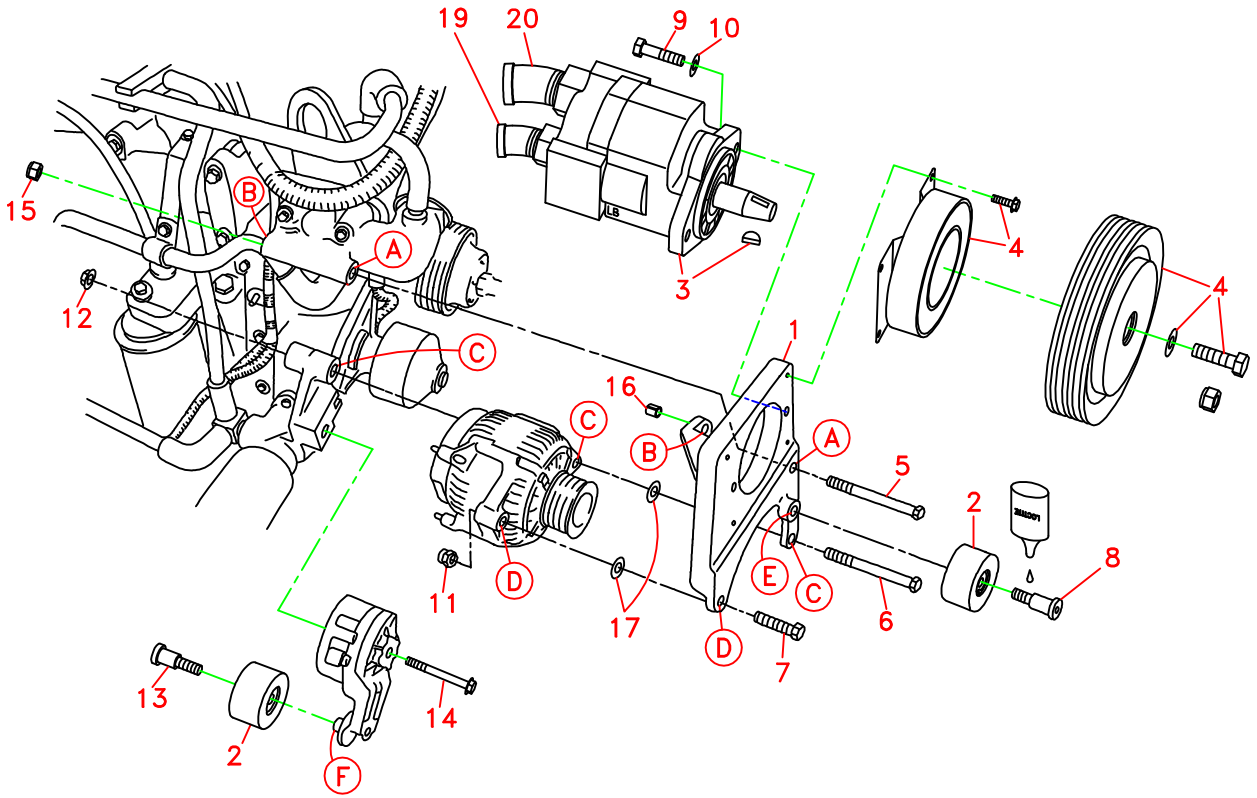
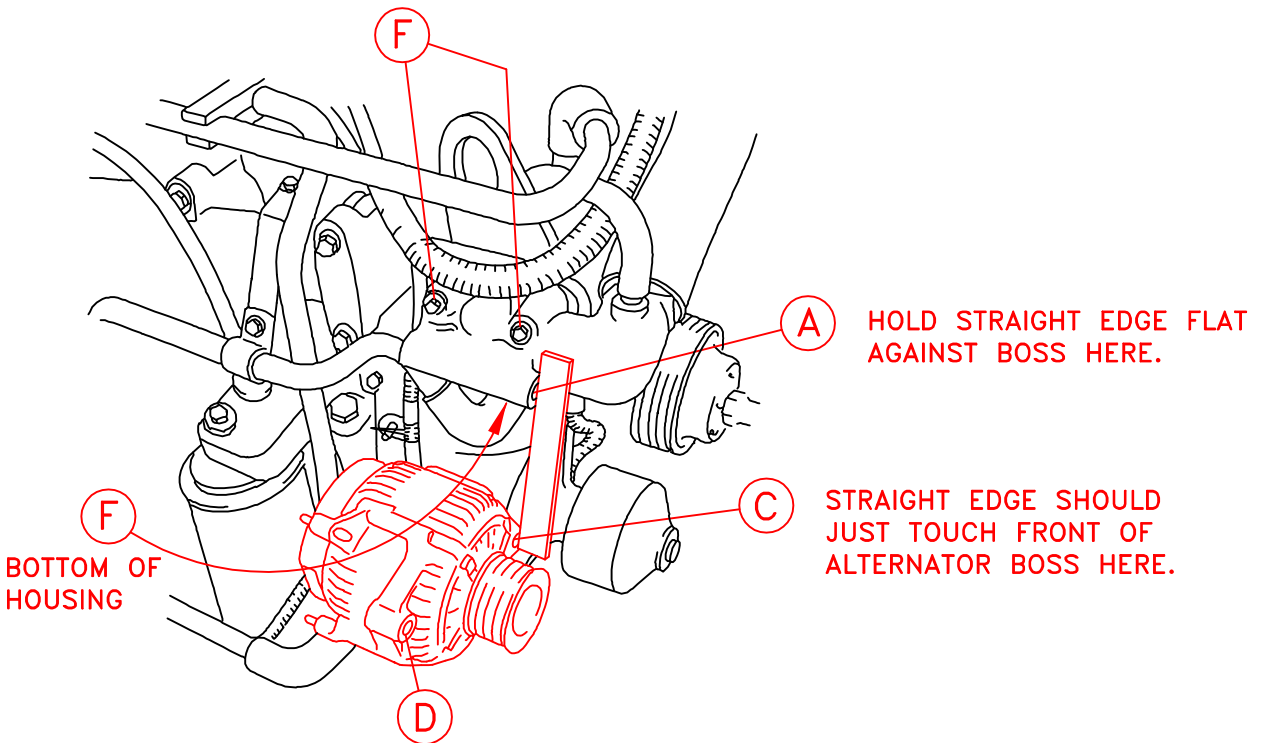

FIG. 6



DewEze

Clutch Pump Kit
#700318
Dodge 5.9L
With A/C
1994-98

INSTALLATION INSTRUCTIONS

NOTE: Suction hose to pump must be a wire braid hose; minimum 1" I.D. for 7 & 9 GPM pumps, 1 1/4" I.D. for 12 & 17 GPM pumps. Installations with smaller suction hoses will void the pump warranty.

1. Disconnect battery.
2. Remove OEM belt.
3. Remove OEM tensioner by removing center bolt (14). Remove OEM idler pulley and washer from tensioner.
4. A notch must be ground in the back of the tensioner to clear the alternator. Grind back .350" from the edge and .450" deep (to edge of spring where it comes through the tensioner). See Fig. 7.
5. Install DewEze idler pulley (2) on tensioner using OEM shoulder bolt (13). Do not use OEM washer that was on rear of OEM idler.
6. Replace tensioner using OEM bolt (14).
7. Remove OEM alternator top bracket and its two mounting bolts.
8. Remove OEM bolt from bottom of alternator (location C), leaving alternator in place on mount.

NOTE: If the thermostat housing on your engine looks like the one in Figures 1 and 2, do steps 8 and 9, skip step 10, and do steps 11 through the end. If your thermostat housing looks like the one in Figures 5 and 6, skip steps 8 and 9, and do steps 10 through the end.

9. Remove bracket and four bolts from thermostat housing. Keep two of the bolts. Install DewEze thermostat bracket (21) using two OEM bolts (22).
10. Refer to Figure 2: Hold a straight edge flat on thermostat housing boss (location A). Boss on alternator (location C) should be in line with location A. If alternator bosses are too far back, place .020" shims (17) at locations C and D behind pump bracket (1).
11. Refer to Figure 6: Hold a straight edge flat on thermostat housing boss (location A). Boss on alternator (location C) should be in line with location A. If not, loosen the three thermostat housing bolts (location F) and pry housing forward until it is in line with the alternator. If thermostat housing will not line up, place .020" shims (18) at locations C and D behind pump bracket (1).
12. Refer to Figure 1: Hold bracket in place and insert 10mm x 120mm bolt (6) through bracket and into bottom alternator hole at Location C. Thread OEM nut (12) onto bolt. Insert 5/16 x 5 bolt (5) through bracket at Location A, threading 5/16 lock nut (15) on back. Insert 7/16 x 2 bolt at location D, threading 7/16 lock nut (11) on back. Tighten all bolts.
13. Insert shoulder bolt (8) through DewEze idler pulley (2). Apply Loctite to bolt threads and mount idler onto boss on pump bracket at location E. Tighten bolt.

14. Install pump onto back of bracket using two 3/8 x 1 1/4 bolts (9) and two 3/8 lock washers (10). Install clutch coil onto front of bracket with four w/z flange bolts supplied in clutch package. Install key and clutch pulley onto pump shaft using bolt and heavy washer supplied in clutch package.
15. Install DewEze serpentine belt (18).
16. Connect the hoses to the pump using 45° elbows as specified in the parts list for your size pump.
NOTE: Tie the hoses to the shock tower as shown in Fig. 3 to keep the hoses away from the turbocharger.
17. Run the engine and check for any clearance or alignment problems. Adjust as needed.