



► Firebolt® Class 3 LED | LED Beacon

FEATURES

- Single flash pattern
- (3) high-powered LEDs
- Cost effective
- Permanent and magnet mount models available
- Polycarbonate base and dome
- Multi-voltage, 12-24 VDC
- Three-year warranty

REPLACEMENT PARTS

- SAE J845, Class 3

A superior warning signal

The Firebolt® Class 3 LED beacon produces a superior warning signal to promote work zone safety. The LED technology in the Firebolt LED allows for a minimal Amp draw of less than 0.5 Amp while meeting Class 3 standards.

Built for versatility and durability

Designed to meet the demands of a variety of work zones including snow plows, forklifts, utility trucks and construction vehicles; the Firebolt Class 3 LED is made of a shatterproof, polycarbonate dome and base that includes an o-ring to help protect against moisture. The Firebolt Class 3 LED is available in both permanent and magnet mount.



Permanent mount



Magnet mount with cigarette-plug



Specify Model

- 220350-02 Permanent mount, 12-24 VDC, Amber
- 220360-02 Magnet mount with cigarette-plug, 12-24 VDC, Amber

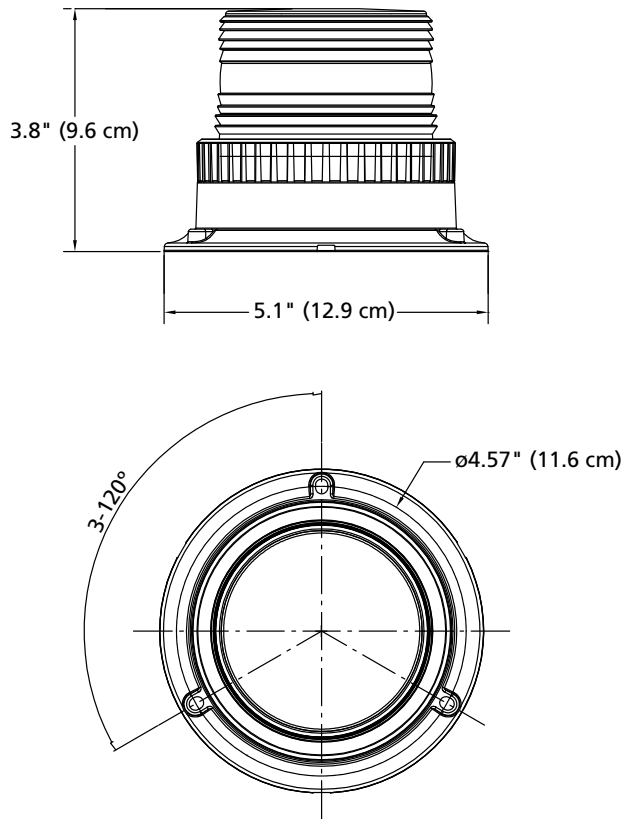

Specifications	
Voltage	12-24 VDC
Amp Draw	< 0.5A @ 12 VDC <0.25A @ 24 VDC
Number of LEDs	3
Approval	SAE J845, Class 3
Physical Specifications	
Height	3.8 in (9.6 cm)
Diameter	5.1 in (12.9 cm)
Ship Weight	
	1.2 lbs (0.54 kg)