

## Safety Message to Installers of Warning Light Equipment

### **⚠ WARNING**

People's lives depend on your proper installation and servicing of Federal Signal products. It is important to read and follow all instructions shipped with this product and the original product. Listed below are some other important safety instructions and precautions you should follow:

- To properly install the lighting system, you must have a good understanding of automotive systems, along with proficiency in the installation and use of safety warning equipment.
- Do not install equipment or route wiring in the deployment path of an airbag.
- If a vehicle seat is temporarily removed, verify with the vehicle manufacturer if the seat needs to be recalibrated for proper airbag deployment.
- When drilling into a vehicle structure, be sure that both sides of the surface are clear of anything that could be damaged.
- Refer to the instructions packed with related products for additional precautions and information.
- This product contains high-intensity LEDs. Do not stare directly into the light at close range or permanent damage to your eyesight may occur.
- For the light to function properly, a separate ground connection must be made. If practical, it should be connected to the negative battery terminal. At a minimum, it may be attached to a solid metal body or chassis part that will provide an effective ground path as long as the light system is to be used.
- To avoid damage the light, ensure that the input voltage is the same voltage as the voltage rating of the light. Ensure that the correct polarity is observed and that the beacon is properly fused.
- Locate the light control so the VEHICLE and CONTROL can be operated safely under all driving conditions.
- Do not attempt to activate or deactivate light control while driving in a hazardous situation.
- You should frequently inspect the light to ensure that it is operating properly and that it is securely attached to the vehicle.
- File these instructions in a safe place and refer to them when maintaining and/or reinstalling the product.

Failure to follow all safety precautions and instructions may result in property damage, serious injury, or death.

## Product Overview

The Firebolt® beacon is equipped with LEDs for zero light maintenance with no bulbs or strobe tubes to replace. The combination of long-lasting LEDs, advanced dome optics and high-intensity flash patterns eliminate dark spots or shadows around the beacon. The beacon includes a black plastic base. The Firebolt meets SAE J845 Class 3 requirements.

## Unpacking the Beacon

After unpacking the beacon, inspect it for damage that may have occurred in transit. If it has been damaged or is missing a part, do not attempt to install or operate it. File a claim immediately with the carrier, stating the extent of the damage. Carefully check all envelopes, shipping labels and tags before removing or destroying them. If you are missing any parts, contact Customer Support at 1-800-264-3578 or 1-708-534-3400 7 a.m. to 5 p.m., Monday through Friday (CT).

### ⚠ WARNING

**AIRBAG DEPLOYMENT**—Do not install equipment or route wiring in the deployment path of an airbag. Failure to observe this warning will reduce the effectiveness of the airbag or potentially dislodge the equipment, causing serious injury or death.

### ⚠ WARNING

**LIGHT HAZARD**—To be an effective warning device, an emergency warning system produces bright light that can be hazardous to your eyes at close range. Do not stare into the light at close range or permanent damage to you eyesight may occur.

### NOTICE

**REVERSE POLARITY/MISWIRING**—Reverse polarity or incorrect voltage may damage the beacon. To avoid damage, ensure that the battery voltage is the same as the voltage rating of the light and that the correct polarity is observed. If you are connecting to a 12 V power outlet, connect the positive wire to the center terminal and connect the negative wire to the outer terminal.

## Surface Mounting the Beacon

### NOTICE

**DRILLING PRECAUTIONS**—Before drilling holes, check the area into which you are drilling to be sure that you do not damage vehicle components. De-burr all drilled holes and smooth all sharp edges. Protect all wires routed through drilled holes with convolute/split-loom tubing.

**IMPORTANT:** Before you begin the installation, plan all wire routing.

To mount the beacon permanently on the vehicle surface:

1. Select a mounting location for the beacon.
2. See Figure 1. Using the base of the beacon as a template, scribe mounting hole locations on the mounting surface. Scribe a wire routing hole location on the mounting surface. Orient a drain slot facing rearward for drainage (Figure 2 on page 3) to minimize the accumulation of wind driven rain and moisture.

Figure 1 Firebolt dimensions

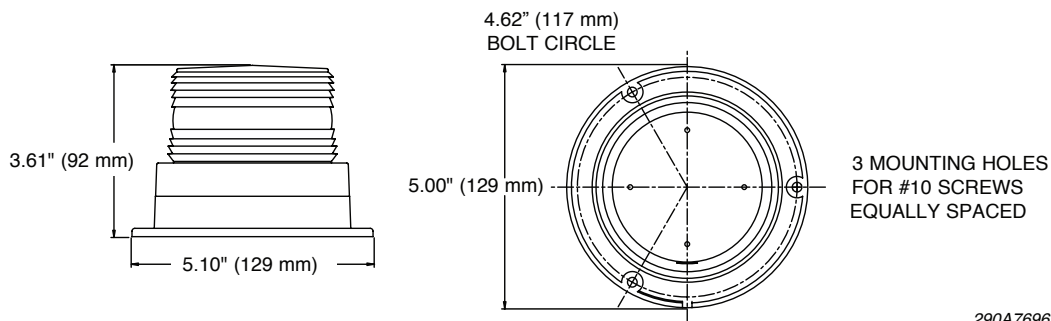

3. Drill three 0.203" holes at the scribed mounting hole locations. Drill a 0.31" hole at the scribed wire routing hole location. Remove all burrs and sharp edges.
4. Install the supplied grommet in the wire routing hole.
5. Center the gasket over the drilled holes and route the wires through the gasket and grommet.

**Figure 2** Beacon mounting and wiring

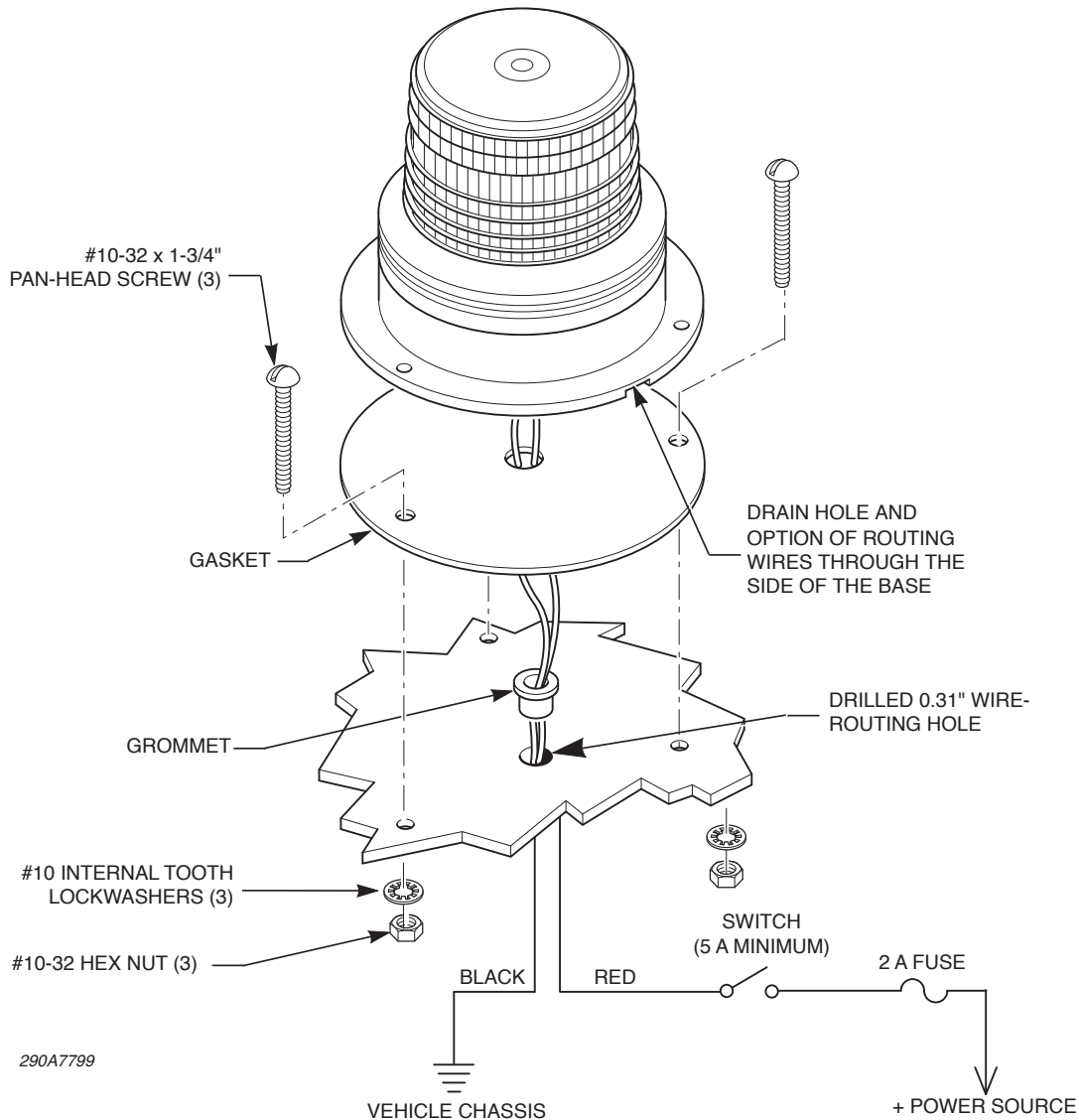

## Wiring the Surface-Mounted Beacon

To wire the beacon:

1. Determine the length of wires needed for the installation. For lengths up to 15 ft (5 m), use minimum 18 AWG (1 mm<sup>2</sup>) wire. For lengths over 15 ft, use minimum 16 AWG (1.5 mm<sup>2</sup>) wire.
2. Strip 1/4 inch (5 mm) of insulation from the ends of the red and black installer-supplied wires.
3. Connect one terminal of an installer-supplied switch with a current capacity of at least 5 A to the red (+) wire of the beacon. Additional 18 AWG (1 mm<sup>2</sup>) or larger wire may be added, if needed.

## Installation Instructions for the Firebolt LED Beacon

---

4. Use 18 AWG (1 mm<sup>2</sup>) or larger wire to connect the remaining switch terminal to one end of the supplied fuseholder and 2 A fuse.
5. Connect the other end of the fuseholder to the positive (+) terminal of the voltage source.
6. Connect the black (–) wire from the beacon to a known good vehicle ground as close to the beacon as practical.
7. Test the beacon for proper operation.

## Magnetic Mounting

---

### **⚠ WARNING**

***DO NOT DRIVE WITH MAGNETICALLY-MOUNTED BEACON INSTALLED—Because vehicle roof construction and driving conditions vary, do not drive a vehicle with a magnetically-mounted beacon installed. The beacon could fly off the vehicle causing injury or damage. Repair of damage incurred because of ignoring this warning shall be the sole responsibility of the user.***

---

The holding power of magnetic mounting systems is dependent upon surface finish, surface flatness, and thickness of the steel mounting surface. Therefore, to promote proper magnetic mounting:

- ✓ Ensure that the mounting surface is flat.
- ✓ The mounting surface and magnets must be kept clean, dry, and free of foreign particles that prevent good surface contact.
- ✓ A magnet mounting system should not be used on vehicles with vinyl tops.
- ✓ To prevent the sliding of the beacon on the mounting surface, avoid quick acceleration and hard stops.

To temporarily mount the beacon to a vehicle with a magnetic mounting system:

1. Place the beacon on the vehicle roof at a location that provides maximum signaling effectiveness for your application.
2. To operate the magnet-mounted beacon, insert the plug at the end of the cable assembly into the 12 V power outlet socket.
3. Test the beacon for proper operation.

## Cleaning the Dome

---

### **⚠ WARNING**

***CRAZING/CHEMICALS—A crazed, cracked or faded dome reduces the light output and the effectiveness of the lighting system. A dome showing this type of aging must be replaced. Failure to follow this warning may result in bodily injury or death.***

---

To clean the dome:

1. Rinse the dome with lukewarm water to loosen dirt and debris.
2. Use a mild soap, lukewarm water, and a soft cloth to gently clean the dome. Do not use heavy pressure or caustic, abrasive, or petroleum-based cleaners.
3. Rinse and dry the dome with a soft cloth to prevent water spotting.