

REV	DESCRIPTION	DATE	APPR

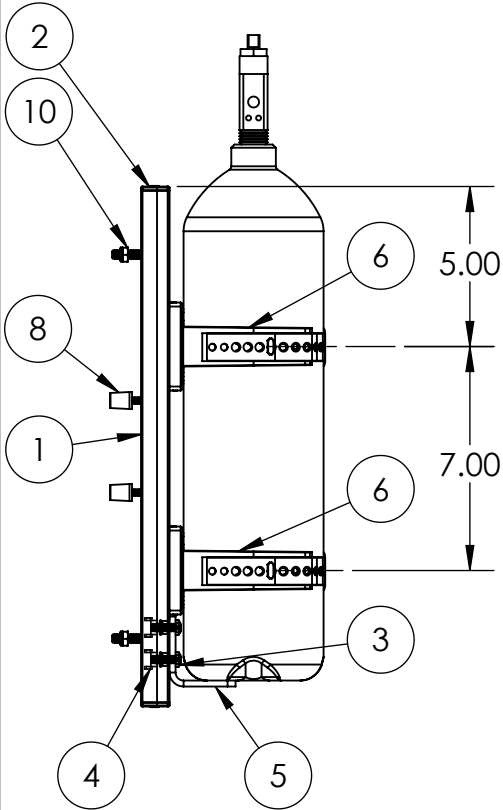
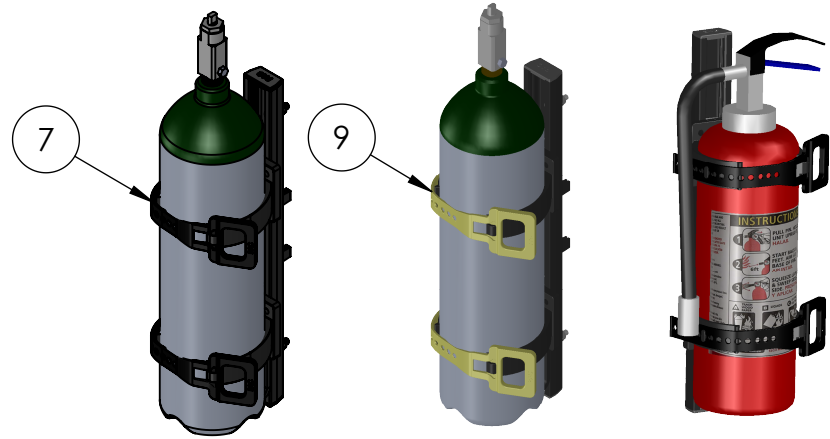
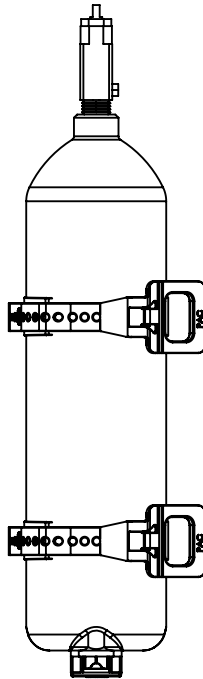

10	2035	FASTENER PACK	1	1	
9	4017-Y	SUPERSTRAP YELLOW	-	2	
8	7029	FASTENER KIT-ADJUSTAMOUNT PT	1	1	
7	4017-B	SUPERSTRAP BLACK	2	-	
6	1104P	SUPERFLEX 4	2	2	
5	1117	BLACK RING MOUNT	1	1	
4	3024	1/4-20 CHANNEL NUT	6	6	A
3	2098-B	14-20 X 3/4 PHIL PANHEAD BLACK	6	6	
2	2019EC	END CAP PAC STRUT	2	2	
1	2019P-B	BLACK PAC STRUT x 16" LG	1	1	
ITEM NO.	PAC P/N	PART NAME			REV

**NOTES:**

**GRIP RANGE: 3-1/2" \* - 4-1/2" DIAMETER**

**P/N'S: K5044-B (BLACK STRAP)  
K5044-Y (YELLOW STRAP)**

**\* WITH STRAP**

**PERFORMANCE  
ADVANTAGE  
COMPANY**



**TOLERANCES UNLESS OTHERWISE SPECIFIED**

.X= ± .03  
.XX= ± .010  
.XXX= ± .005  
.XXXX= ± 0.0005  
ANGLES ± 0.5 °  
FRACTIONAL ± 1/64

THIRD ANGLE PROJECTION



COLOR

	NAME	DATE
DRAWN BY	JPG	3-25-21
APPR. BY		
MFG BY		
MFG. P/N		
ENG APPR.		
MATERIAL		
ALT. MATERIAL		
FINISH		

THE INFORMATION CONTAINED IN THIS DRAWING IS THE SOLE PROPERTY OF **PERFORMANCE ADVANTAGE CO.** ANY REPRODUCTION IN PART OR AS A WHOLE WITHOUT THE WRITTEN PERMISSION OF PERFORMANCE ADVANTAGE CO. IS PROHIBITED.

**TITLE:**

**O2 CYLINDER/5LB EXT. MOUNT**

**PART NUMBER**  
**K5044 - B (BLACK)**  
**- Y (YELLOW)**

REV

**SCALE: 1:6**

**SHEET 1 OF 1**