

TRAILER OPERATION

To load or unload the Landoll Hauloll, first park the tractor and trailer in a straight line on relatively level ground. Set the tractor brakes while releasing the trailer brakes. This is necessary for the trailer axles to be able to move freely. Make sure hydraulic lines are connected and engage PTO.

Before pulling the axles forward, raise the trailer to the approximate loading angle. Then pull the axles to the full forward position. Adjust trailer angle if necessary until the rear of the trailer rests on the ground. You are now ready to drive or winch on the load.

The preceding paragraph is standard procedure, however the operator must use his own judgment. If the load is unbalanced with more weight on the king pin than on the trailer axles, pull the axles a few feet forward to balance out the load before tilting the trailer.

To return the trailer to level position, reverse the steps used to tilt the trailer.

WINCH OPERATION

Warning!

Goods are not designed for use in the lifting or moving of persons! The winches described herein are neither designed nor intended for use or application to equipment used in the lifting or moving of persons. The cable clamps alone on winches are not designed to hold rated loads. Therefore, a minimum of 5 wraps of cable must be left on drum barrel to achieve rated load. Any damage resulting when less than 5 wraps are used will void the warranty.

COMBINE WELL OPERATION

To use combine wells on LHA4 and gooseneck trailers loosen clamp on underside of combine well then lift and pull out then lift and pull out combine well to desired width. Ensure that support chains are adjusted to equal lengths. With combine wells in extended position proceed to above procedure for tilting trailer.

To use combine wells on Model LHA5 trailers remove safety pin and pull out and up until combine well rests on the short storage leg. Slide support tube in and place support chain loops on chain support bar. Lower trailer to loading position and then pull combine well out until storage leg is clear. (Fig. 1) Back combine on until back tires are past combine well. Then raise trailer until front end of combine well drops past its support. Lower trailer to ground again. (Fig. 2)

Back combine to where the drive wheels are centered on the larger section of the combine well. (Fig. 3 & 4)

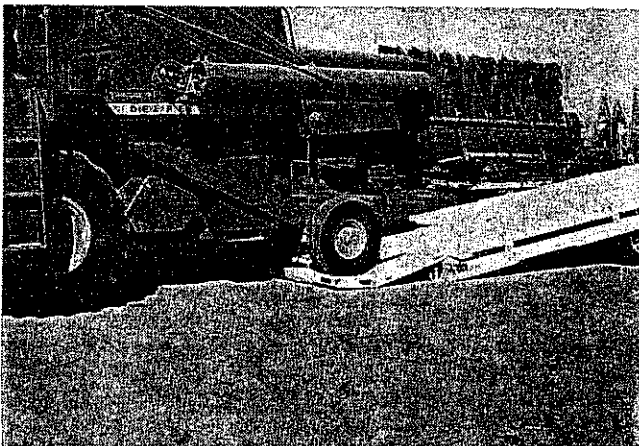

Fig. 1



Fig. 2

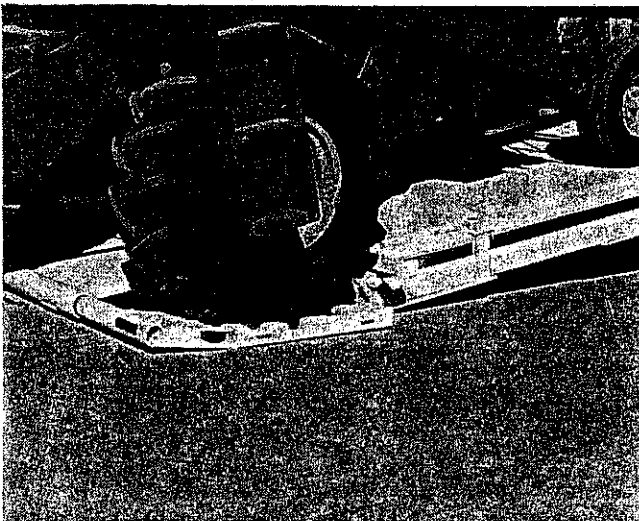

Fig. 3

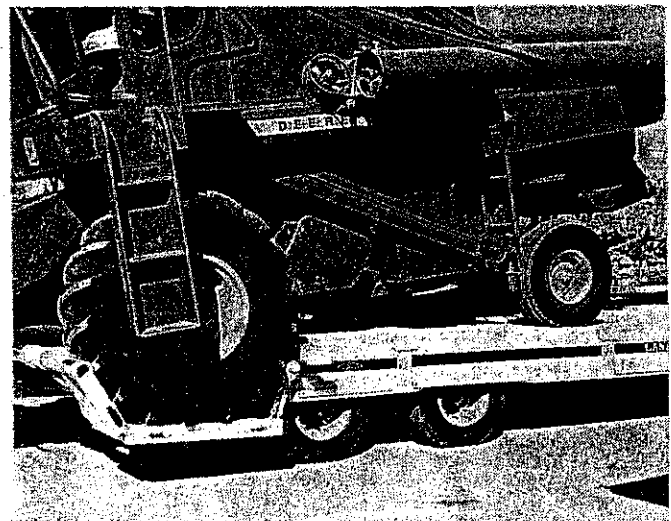

Fig. 4

Phone 913-562-5381

DONALD R. LANDOLL
President



1700 May Street
Marysville, Kansas 66508

Home of Quality

Liquid Feeders
Chisel Plows
Hauloff Trailers
Pickup Racks
Quality Fabrications

June 23, 1978

Tudor & Jones
Weedsport, New York 13166

Dear Mr. Jones,

We appreciate your calling to our attention the incompleteness of our Service Manual concerning the "Maintenance Schedule". We assumed that the note on the bottom of the page- "Circled number indicates recommended lubricant listed on following page"- was sufficient explanation. However, this will be corrected. You are correct that the wheel bearings should have a life expectancy far in excess of 30,000 miles. If you will return the removed parts, we will endeavor to recoup credit for same. Please use return authorization #0006 (enclosed) for shipment.

The free wheeling on your winch, if properly lubricated should not seize. It may well be that running on heavily salted roads could aggravate the problem. May I suggest to you to lubricate from the under side of the curb side leg, that area of the winch to free up the clutch that slides on the cable drum shaft and the shifter fork. If the above does not free up the clutch, removable disassembly of the bearing leg assembly and lubrication may be required.

Please advise if we can be of service

Sincerely,

A Rudy Belknap

enc/jo
cc Jerry
Bob

Tudor & Jones

Farm
Equipment
Distributor

Weedsport, N. Y. 13166 • Phone: (315) 834-6661

Established 1906

June 20, 1978

Rudy Belknap
Landoll Corporation
Box 269, 1700 May Street
Marysville, Kansas 66508

Dear Rudy:

Please note that on your lubrication schedule, the item we circled is a little misleading. Our man understood the instructions to mean that the wheel bearings be changed at 30,000 miles. I did not look at the instructions, but assumed that he was correct and okayed the move. We took it to a place in Syracuse, New York who proceeded to change the wheel bearings. Apparently this was not at all necessary, although this firm in Syracuse claimed that the bearings showed signs of scoring. We think we were imposed upon. A representative from C. C. Kelley & Son was here and said that the wheel bearings on that trailer should last much longer than 30,000 miles.

We would appreciate your comments regarding this matter. Also we would suggest that you make this maintenance schedule a little plainer.

Yours truly,

CGNJ/fs
enc.

TUDOR & JONES

*The free wheeling of our
which is "seized". Do you
have a better arrangement
than that one! ?*

Prompt and Courteous Service Since 1906

Maintenance Schedule

- 5,000 mi. or 60 days.
Check the following:
- ① Hydraulic oil tank (3/4 full.)
 - ② Winch oil level.
 - ⑤ Reservoir, brake master cylinder.
- 5,000 mi. or 60 days.
Check the following on bushing for gooseneck swivel hitch mounted in truck bed.

- 5,000 mi. or 60 days.
- ③ Slack adjuster.
 - Cam bracket bushing
 - Brake spider bushing
 - LHA4 and LHA5.

- 30,000 mi.
- ④ Cam rollers.
 - Retainer springs.
 - Anchor pins.
 - LHA4 and LHA5.

- 5,000 mi. or 60 days
- ④ Equalizer mounting bolt, LHAG only.

- 5,000 mi. or 60 days
- ④ Combine well slides.
 - 4 fittings.

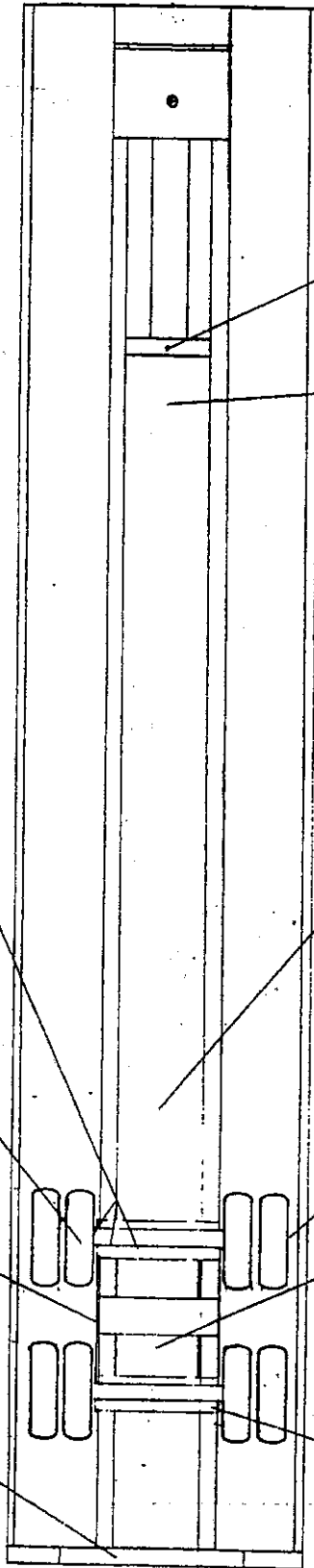

- ④ 1 fitting - 5,000 mi. or 60 days. Hinge, 5th wheel gooseneck, LHA4 and LHA5 only.

- ④ 5,000 mi. or 60 days. Fittings on cable drum and bearing leg of winch.

- ④ 5,000 mi. or 60 days. Track for cylinder support slide. LHA5 only. Clean track and coat with grease.

- ③ Check 5,000 mi. or 60 days. Wheel bearings all models. Change 30,000 mi.

- ④ 5,000 mi. or 60 days. Cylinder rod bushing. 1 fitting, LHA5 only.

- ④ 5,000 mi. or 60 days. Carriage rollers. 16 fittings on LHAG and LHA4. 4 fittings on LHA5.

Circled number indicates recommended lubricant listed on following page.

Maintenance Schedule

5,000 mi. or 60 days.
Check the following:

- ① Hydraulic oil tank (3/4 full.)
- ② Winch oil level.
- ⑤ Reservoir, brake master cylinder.

- ④ 5,000 mi. or 60 days. One fitting on bushing for gooseneck swivel hitch mounted in truck bed.

5,000 mi. or 60 days.

- ③ Slack adjuster.
- Cam bracket bushing
- Brake spider bushing
- LHA4 and LHA5.

30,000 mi.

- ④ Cam rollers.
- Retainer springs.
- Anchor pins.
- LHA4 and LHA5.

5,000 mi. or 60 days

- ④ Equalizer mounting bolt, LHAG only.

5,000 mi. or 60 days

- ④ Combine well slides. 4 fittings.

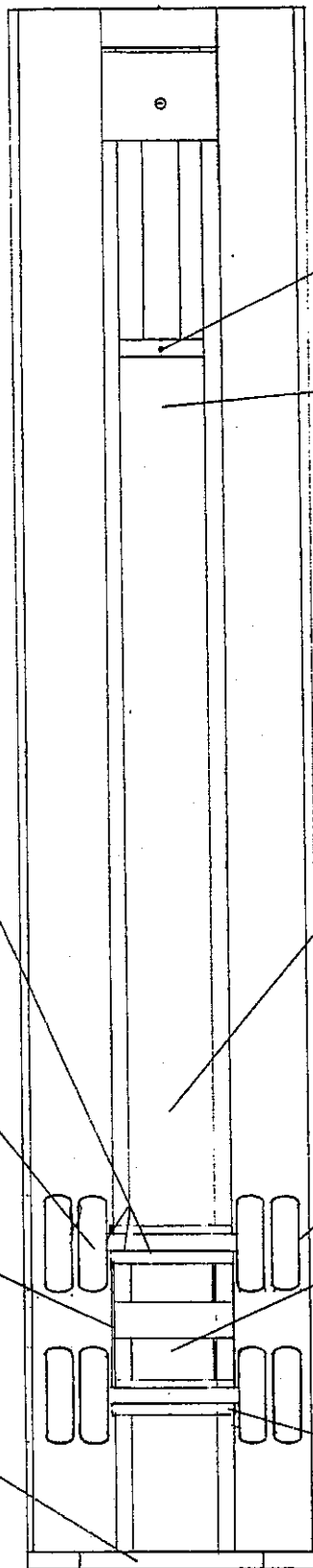

- ④ 1 fitting - 5,000 mi. or 60 days. Hinge, 5th wheel gooseneck, LHA4 and LHA5 only.

- ④ 5,000 mi. or 60 days. Fittings on cable drum and bearing leg of winch.

- ④ 5,000 mi. or 60 days. Track for cylinder support slide. LHA5 only. Clear track and coat with grease.

- ③ Check 5,000 mi. or 60 days. Wheel bearings all models. Change 30,000 mi.

- ④ 5,000 mi. or 60 days. Cylinder rod bushing. 1 fitting, LHA5 only.

- ④ 5,000 mi. or 60 days. Carriage rollers. 16 fittings on LHAG and LHA4. 4 fittings on LHA5.

Circled number indicates recommended
lubricant listed on following page.

AXLE ALIGNMENT INSTRUCTIONS TRANSPRO HEAVYWEIGHT

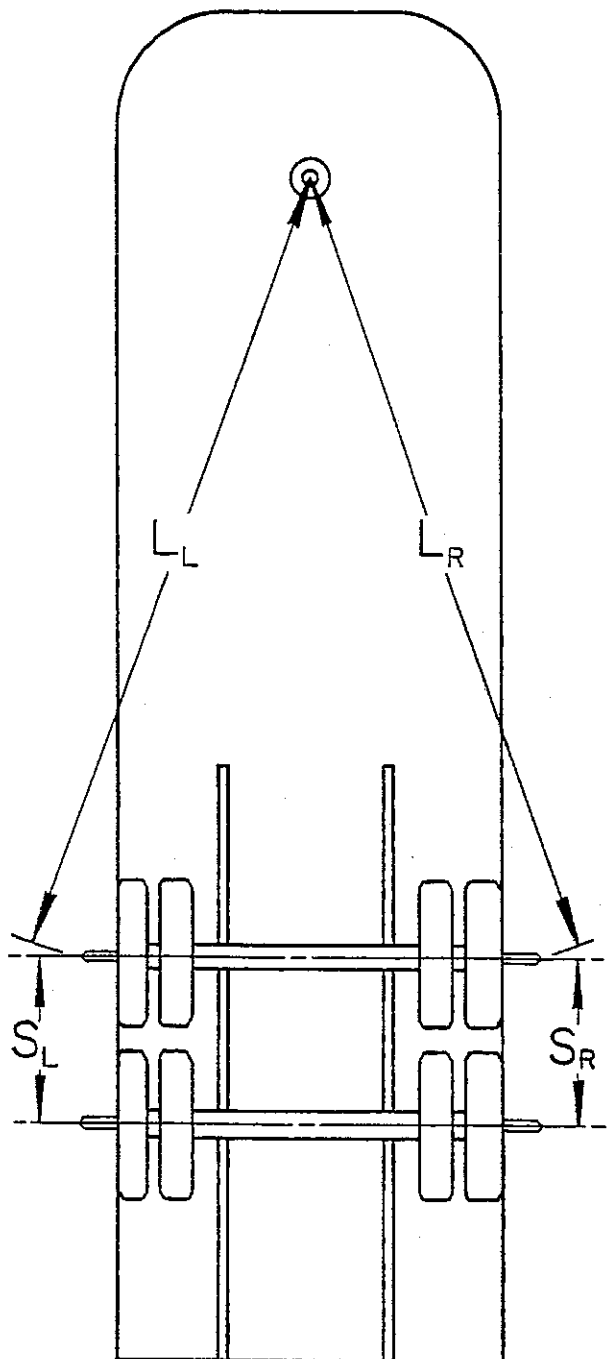

AFTER SUSPENSION INSTALLATION, AND PERIODICALLY THEREAFTER, AXLES SHOULD BE ALIGNED TO INSURE PROPER TRACKING OF TRAILER AND TO AVOID EXCESSIVE TIRE WEAR. FOR BEST RESULTS THE USE OF AXLE AND KING-PIN EXTENSIONS, OR A SUITABLE OPTICAL ALIGNMENT DEVICE, IS RECOMMENDED.

1. Level the empty trailer and bleed air reservoir.
2. Make certain that the equalizers are level and that all spring ends are bearing on wear pads.
3. Align the front axle with the king-pin by adjustment of the forward adjustable torque arm. When properly aligned L_L will equal L_R .
4. In like manner align the rear axle with front axle so that $S_L = S_R$.
5. Tighten adjustable torque arm clamp bolts to 50 lb. ft. torque.
6. After loaded run-in period of 1,000-2,000 miles the axle alignment should be checked and corrected if necessary.

$$L_L = L_R \pm \frac{1}{16}$$

$$S_L = S_R \pm \frac{1}{16}$$



SUSPENSION SYSTEMS FOR THE TRAILER INDUSTRY

TRANSPRO HEAVYWEIGHT TRAILER SUSPENSION

MAINTENANCE RECOMMENDATIONS

The Heavyweight trailer suspension, by design, requires an absolute minimum of maintenance. However, suspensions in "over the road operations" require periodic checks to assure continued trouble free performance. We recommend, after an initial loaded run-in period of at least 1,000 miles, the trailer alignment should be rechecked and corrected. Furthermore, all fasteners, especially U-bolts, should be retorqued to specifications below.

1. Check U-bolt nuts to assure that 300 ft. lbs. torque is maintained.
2. Check all hanger mounting bolts to assure tight fit of hanger to frame.
3. Check equalizer thru-bolt to assure that 480-500 ft. lb. torque is maintained.
4. Check torque arm bolts to assure that 250 ft. lbs. torque is maintained.
5. Check torque arm tube clamp nuts to assure that 80 ft. lbs. torque is maintained.

We recommend further inspections at 90 day intervals on the above items.

TRM-275

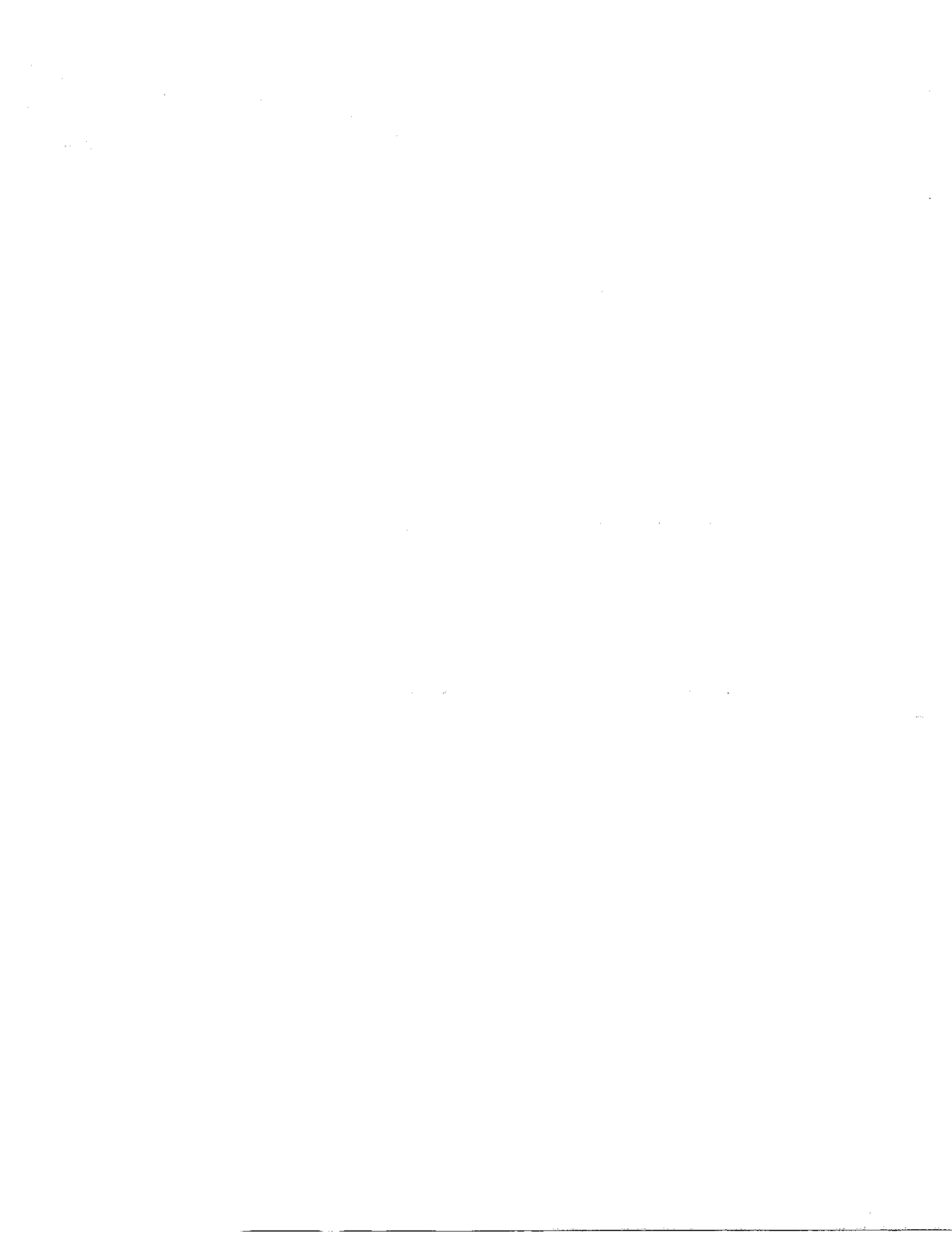

Tire Load Chart

8.25 x 15 Tires on Goodyear 6515LWD Rims

Maximum inflation pressures at normal highway speeds 100PSI for bias tires and 105PSI for radial tires.

Tire	Ply Rating	Max. Pressure	Max. Load*
Michelin Radial	14	105PSI	3660# @ 50 MPH 4130 @ 51-55 MPH
Other Radials	12	95PSI	3260#
	14	105PSI	3470#
Bias Ply	12	90PSI	3260#
	14	100PSI	3470#

* Max. load per tire, used as duals

MAX. INFLAT. PRESSURE PER GOODYEAR FOR RIM 100PSI FOR BIAS TIRE 105PSI FOR RADIAL TIRE
 MAX LOAD 4290 LBS

Complete Rim 6515LWD Goodyear

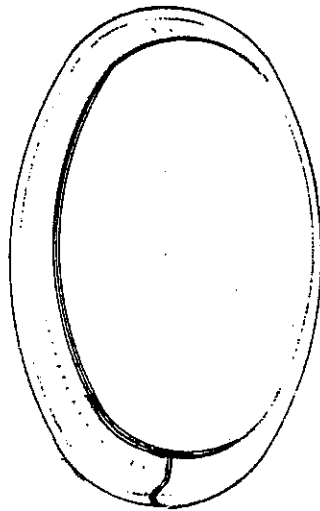

R6515LW
Side Ring

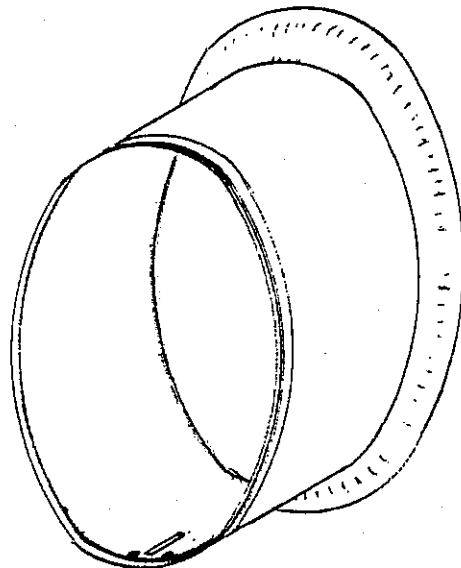

B6515LWD
Rim Base

*Part on back
of rail tank case*

Fifth Wheel Latch

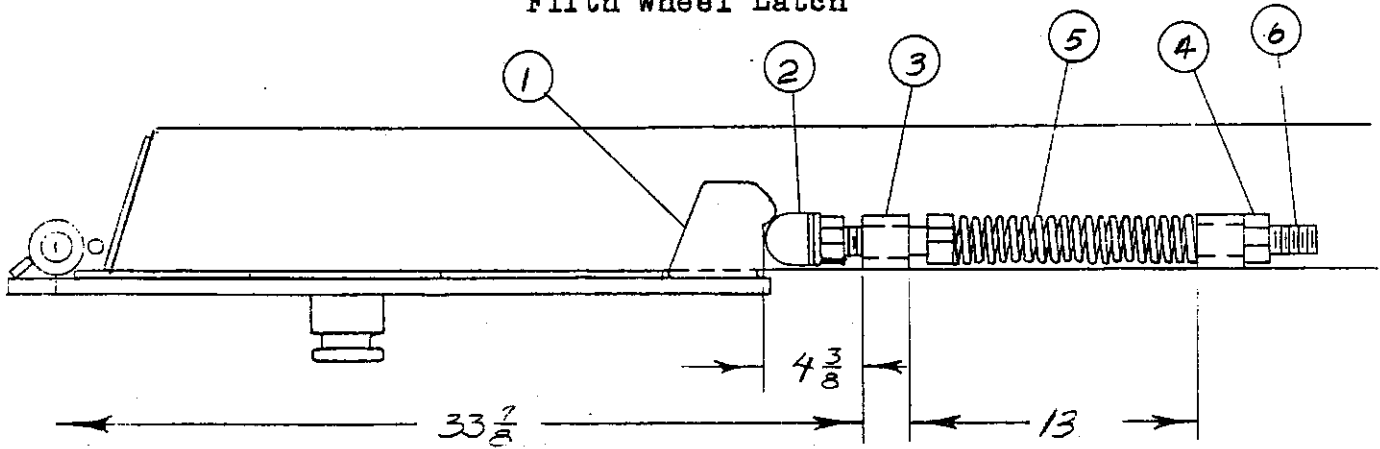

<u>Item</u>	<u>P/N</u>	<u>Description</u>	<u>Qty.</u>
1	3-311-010165	Latch, 5th Wheel	1
2	3-311-010164	Cam, 5th wheel latch	1
3	RRT113-2	Bushing	2
4	1 1/4"-7 NC	Hex Nut	2
5	2-720-010002	Spring	1
6	3-642-010006	Latch Rod	1

Note: When installing this fifth wheel latch on older model trailers all items listed above in the quantities listed must be ordered.

To adjust 5th wheel latch assy. support fifth wheel plate and adjust rear nut until the cam just touches the flat surface on the latch. Then tighten the other nut compressing the spring to approximately 10 3/8" or until there is sufficient tension to hold the 5th wheel plate in place. To check the tension on the latch place a pry bar between the 5th wheel plate and the backing plate and pry down until the latch releases. If it releases too easily tighten the spring tension. If you are unable to trip it, back off the spring tension until you are able to trip the release. Too much tension will cause excessive wear on the release and possibly bend the latch rod.

BRAKE ADJUSTMENT

Prior to shipping, Standard Forge axles with brakes and drums have the brakes adjusted to provide maximum braking. However, if after the axle is installed on the trailer, or when linings are later replaced and the brakes require re-adjusting, the following procedure should be followed:

1. Have the wheel raised off the ground

While many people attempt to adjust brakes with the wheel on the ground, it is very unlikely that satisfactory adjustment can be made in this manner. Bearing and drum wear, lining radius tolerances, and the relationship of the radial dimensions of component parts with the weight of the trailer on the axle, will not allow for true alignment to afford maximum braking without brake "drag".

2. Adjusting slack

A. With the wheel turning slightly (by hand), rotate the adjusting screw on the slack adjuster until the wheel is locked by the brakes.

B. Back off the adjusting screw until the wheel turns freely with no evidence of brake "drag". (Usually two (2) "clicks" of the slack adjuster screw is sufficient to provide the proper clearance.)

3. Brake lining

A. Linings should be inspected for wear at least every 30,000 to 40,000 miles

B. Lining wear—"Rule of Thumb"

After adjusting brakes, if the brake will not release (cam returns to closed position), the linings should be replaced.

Under no circumstances should linings be used to the point where the rivets or screws are above or level with the lining surface.



A19S-FS75-LHDA Weld-On Spider Fabricated Shoe

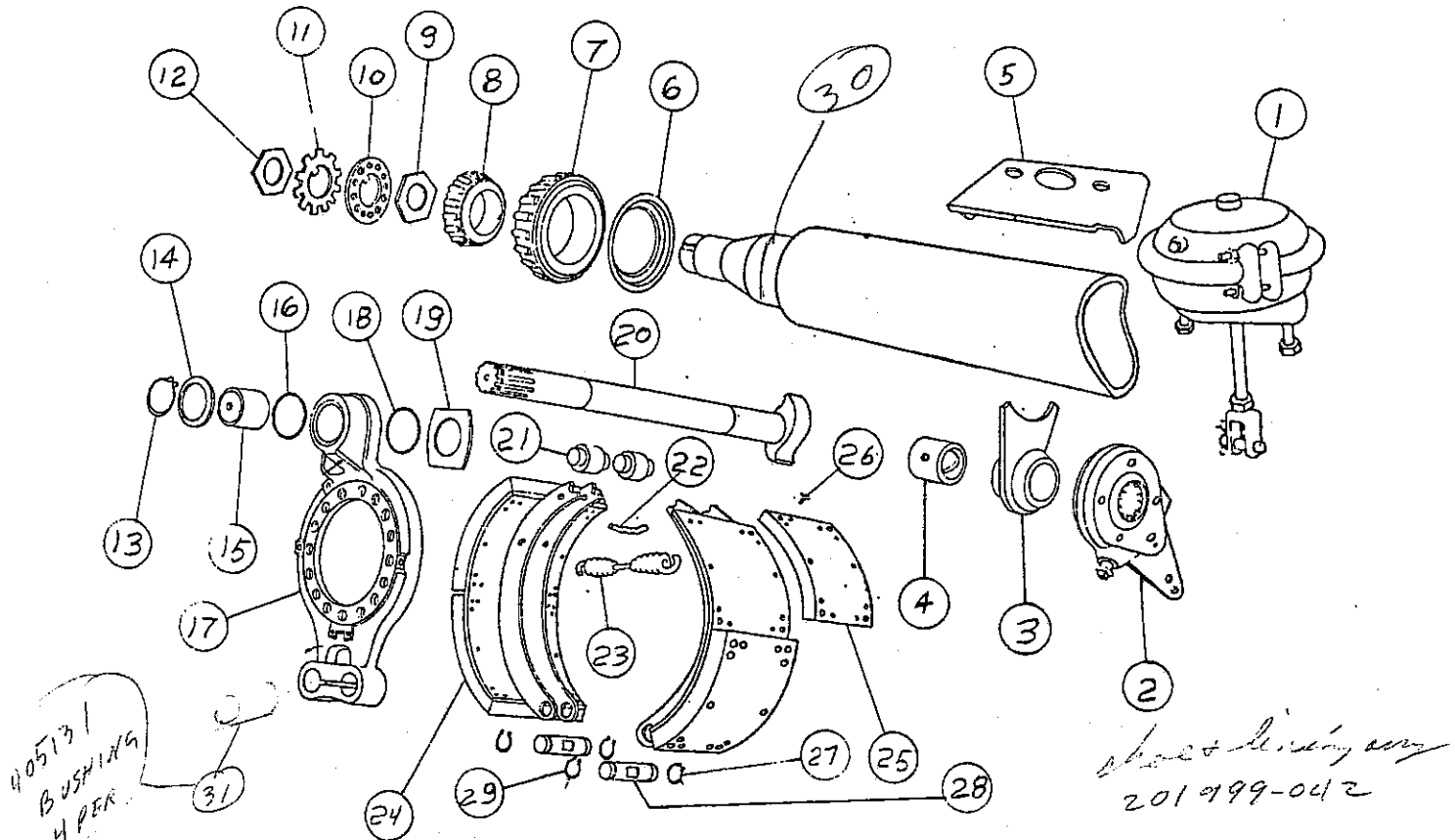

<u>NUMBER</u>	<u>PART NUMBER</u>	<u>QUANTITY</u>	<u>DESCRIPTION</u>
1	217024-054	2	Air Chamber
2	212102	2	Slack Adjuster
3	209999-019	2	Cam Bracket-Assy.
4	405128	2	Cam Bushing
5	210111	2	Air Chamber Bracket
6	2109 106999-019	2	Grease Retainer
7	663	2	Bearing-Inner
8	HM 212049	2	Bearing-Outer
9	103103-002	2	Nut Inner Spindle
10	105107	2	Washer Spindle
11	105106	2	Washer-Star Lock
12	103102-001	2	Nut-Outer Spindle
13	214104	2	Lock Ring-Cam Shaft
14	403105	2	Washer-Spacer
15	405129	2	Bushing-Spider
16	408101-001	2	Seal-spider
17	200115-001	2	Spider-Weld on
18	408101-001	2	Break Spider seal
19	403150	2	Retainer-Cam shaft
20	*202103-213	2	Cam Shaft L & R
21	204108-001	4	Brake Roller
22	207100	4	Spring Retainer
23	208106	2	Retract Spring
24	201140	4	Brake Shoe
25	213131 4591	21	Lining-Anchor End & Cam End
26	404101-001	96	Rivet-Brake Shoe
27	214107	4	Anchor Pin Lock
28	203108	4	Anchor Pin
29	214107	4	Anchor Pin Lock
*	202103-213	21 3/8	cam shaft
30	150.7	2	SEAL RING
	202103-184	18 1/2	cam shaft

83153CCA Webb 15 inch, 3 Spoke Wheel

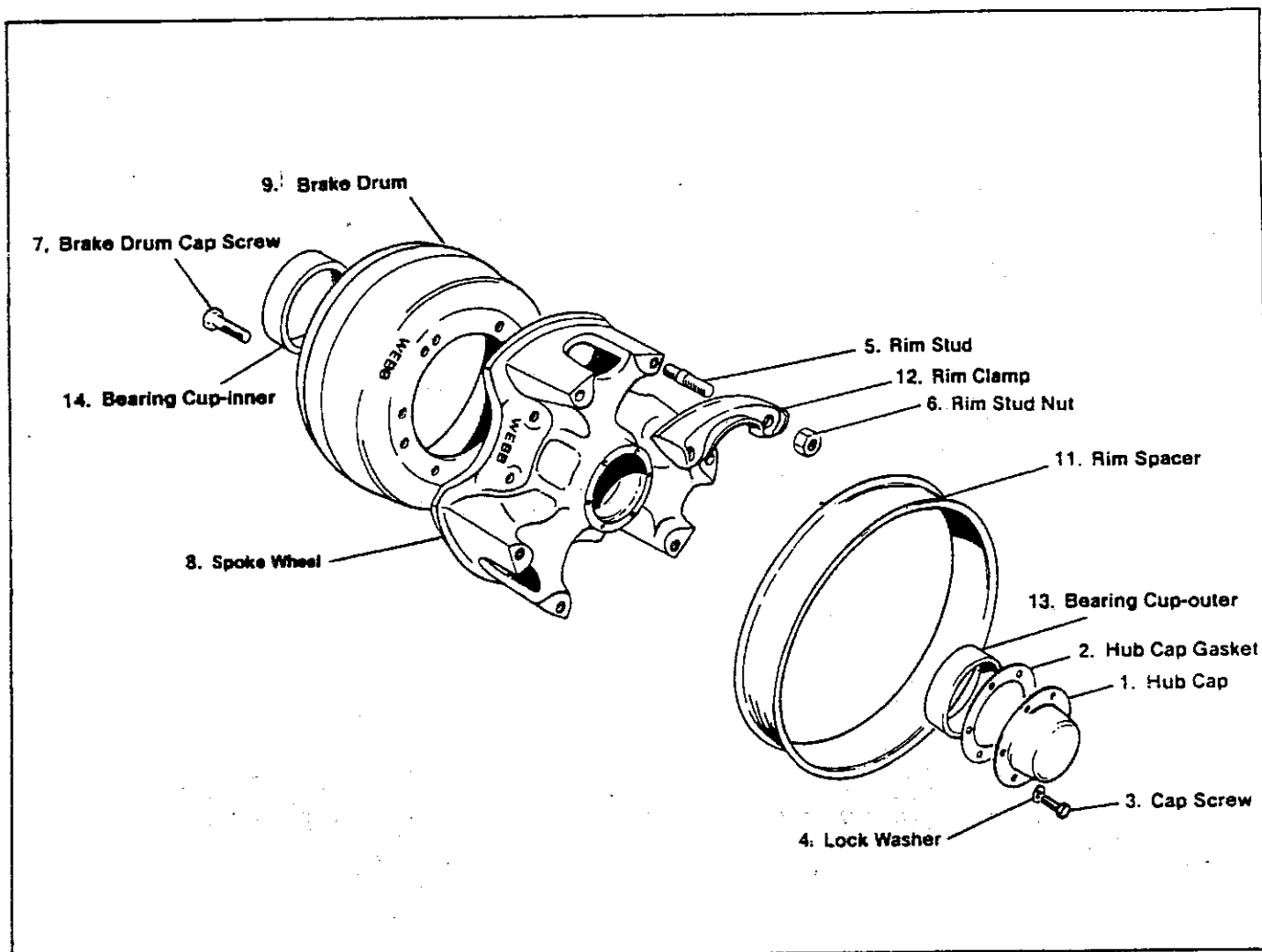

<u>ITEM</u>	<u>DESCRIPTION</u>	<u>PART NO.</u>	<u>QTY.</u>
1	Hub Capw/plug	70655	1
2	Hub Cap Gasket	72655	1
3	Hub Capscrew	83175	6
4	Lock Washer	103	6
✓ 5	Rim stud	171027	6
✓ 6	Rim stud nut	74710	6
✓ 7	Brake drum capscrew	96218	6
✓ 8	3 Spoke Wheel	8315	1
✓ 9	Brake drum	63617	1
✓ 11	Rim spacer	41540	1
✓ 12	Rim clamp	3314	3
✓ 13	Bearing cup outer	HM212011	1
✓ 14	Bearing cup inner	653	1

HW-UM-2-5R-1-U-3H

SUSPENSION, 3 LEAF

1. 0049-00 Hanger, front, undermount
2. 0030-00 Torq. arm adjust, complete assy.--includes the
0032-01 Eye end, L. H. adj. torq. arm following
0032-02 Eye end, R. H. adj. torq. arm
0029-00 Screw adjusting, adj. torq. arm
0022-00 Bushing, rubber, torq. arm
0001-19 Bolt, hex $\frac{1}{2}$ "-20 x 3"
0002-05 Nut, hex, lock, $\frac{1}{2}$ "-20
3. 0001-08 Bolt, hex $\frac{7}{8}$ "-14 x $5\frac{1}{4}$ "
4. 0002-12 Nut, hex, lock $\frac{7}{8}$ "-14
5. 0102-14 U-bolt $\frac{7}{8}$ "-14 x 5" rd. x 14"
6. 0304 Seat, spring, underslung
7. 0379 Spring roller, 3.94 long
8. 0001-09 Bolt, hex $\frac{1}{2}$ "-20 x 5"
9. 0002-05 Nut, hex, lock $\frac{1}{2}$ "-20
10. 0378 Spring roller 3.44 long
11. 0058-00 Equalizer beam assy.
0106-00 Bushing and shaft assembled
12. 0065-00 Hanger, equalizer, undermount
13. 0001-14 Bolt, hex 1"-14 x $6\frac{1}{4}$ "
14. 0002-10 Nut, hex, lock 1"-14
15. 0031-00 Torq. arm, non adj.
16. 0374-00 Liner, spring
17. 0338-00 Plate, bottom U-bolt, underslung
18. 0079-02 Spring-three leaf, high arch
19. 0053-00 Hanger, rear, undermount

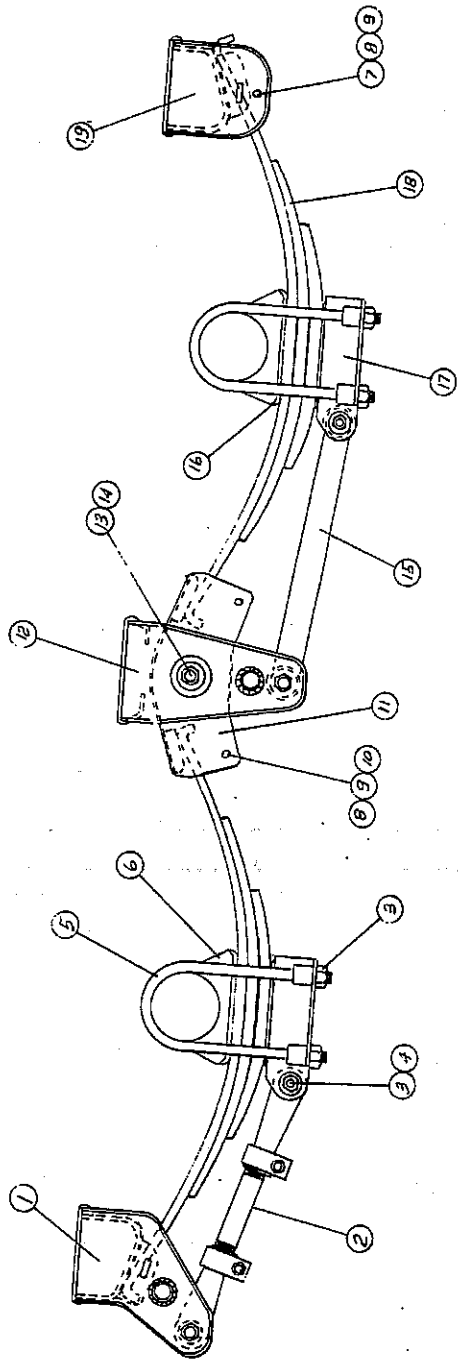

rec. from itd. force 8-8-78

TIMKEN TRAILER WHEEL BEARINGS

RECOMMENDATIONS FOR LUBRICATION AND ADJUSTMENT

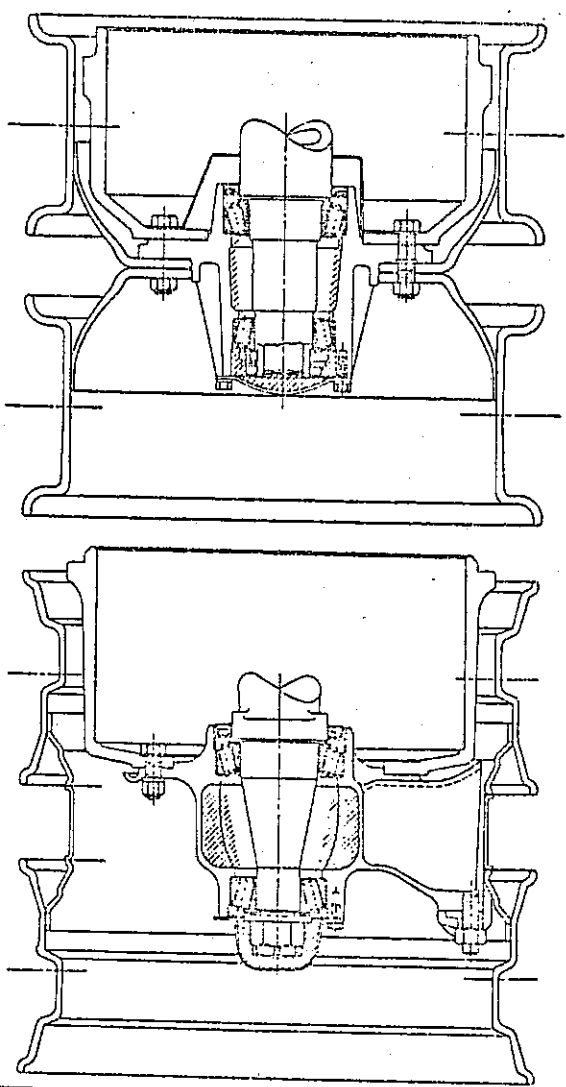

FIGURE 1

FIGURE 2

WHEEL BEARING ADJUSTMENT FOR GREASE OR OIL LUBRICATION

FIGURE 1 SINGLE ADJUSTING NUT

Tighten the adjusting nut with a 12" wrench, at the same time turn wheel in both directions, until there is a slight bind to be sure all bearing surfaces are in contact. Then back off adjusting nut 1/6 to 1/4 turn or to the nearest locking hole or sufficiently to allow the wheel to rotate freely within limits of .001" to .010" end play. Lock nut at this position.

FIGURE 2 DOUBLE ADJUSTING NUTS

Tighten inner nut with 12" wrench, while turning the wheel in both directions, until there is a slight bind so all bearing surfaces are in contact. Then back off inner nut 1/3 turn to allow the wheel to rotate freely. Install lockwasher. Tighten jam or outer nut. Final bearing adjustment should be with .001" to .010" end play. Lock nuts at this position.

WHEEL BEARING LUBRICATION

GREASE: Shading indicates the recommendation for the correct amount of grease in wheel hub. (Fill wheel hub with grease to inside diameter of outer races and also fill hub grease cap.) Never use grease heavier than 265 A. S. T. M. penetration (No. 2 grade).

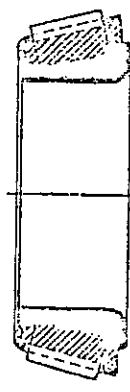

Grease bearing cone by machine or by hand method. Force grease between rollers, cone, and cage.

OIL: Fill hub with oil to the required level as indicated on the hub cap. Follow equipment builder's recommendation for type of oil to use. Oils generally recommended are:

- A. SAE 90 or 140 EP gear oil (standard rear axle oil).
- B. 30 WT motor oil.

B-38754A

DONT MIX PARTS USE TIMKEN CUPS WITH TIMKEN CONES

THE TIMKEN ROLLER BEARING COMPANY
CANTON, OHIO, U. S. A.



rec. from Std. form 8-8-78

TRAILER WHEEL BEARING AND SPINDLE NUT ADJUSTMENT

Wheel bearings must be correctly adjusted and properly lubricated at regular intervals to achieve maximum bearing life, prevent damage to wheels, axles, and possibly the trailer. Changing the wheel bearing lubricant is recommended every 20,000 to 25,000 miles or twice a year, depending on vehicle speed, loads, and general operating conditions. Proceed as follows when changing lubricant and inspecting bearings:

- Step 1: Remove wheel assembly and bearing cones from axle spindle. Clean all old lubricant from hub of wheel, bearings, and hub cap with a good grade commercial cleaner and a stiff brush, NOT STEEL. DO NOT USE AIR HOSE IN CLEANING OPERATION. Avoid spinning cone while cleaning.
- Step 2: Wipe the cleaned parts dry with clean absorbent cloth or paper. Clean and dry hands and all tools used in the service operation. Lubricant will not adhere to a surface which is wet with solvent, and the solvent may dilute the lubricant. CLEANLINESS IS MOST IMPORTANT.
- Step 3: Inspect seals, seal wiping surfaces, bearing cups, and bearing cones for wear or damage. Handle all parts carefully during cleaning, inspection, and installation, to prevent damage to bearing cage, rollers, and cone.
- Step 4: Check bearing cones with cups for correct fit and number. The bearing (cup and cone) MUST MATE.

Example:	CUPS	CONES
	563	528
	552	567
	653	663
	HM212011	HM212049
	HM218210	HM218248
	HM212011	HM212049

CAUTION: ALWAYS USE CORRECT CUP WITH MATING CONE, NEVER MIX PARTS. See current wheel catalog for a complete listing of cups and cones.

- Step 5: A. Oil lubricated bearings - should have a SAE-90 gear type oil spread on all parts before assembly.
- B. Grease lubricated bearings - pack the bearings with a pressure packer if possible using an approved lubricant of medium consistency, ASTM penetration 265-295 (No. 2 lube). If a pressure packer is not available, pack bearings by hand by forcing the grease into the cavities between the rollers and cage from the larger end of the cone. Coat inside the hub cup with a light coat of grease, to prevent moisture accumulation.

Step 6: Be sure air tank is drained and release brake shoes so there will be no possibility of brake shoe drag interfering with bearing adjustment. Assemble and adjust wheel bearings as follows:

- A. If grease is used, fill the cavity of the wheel between the bearing cups to a level of the bearing cup diameter.
- B. Determine inner cup number and install matching cone in wheel, then check to see that the cone is properly seated in the cup.
- C. Install oil or grease seal as recommended by manufacturer.
- D. Install wheel on axle, being careful not to damage the bearing cups, cones or seal. Special care should be taken with wedge type brakes to align wheel assembly with axle, being careful not to damage the seal.
- E. Determine outer cup number and install matching cone, then check to see that the cone is properly seated in the cup.
- F. Install wheel bearing adjusting nut. Screw adjusting nut against the bearing or thrust washer as the wheel is being revolved in both directions, to expell excess lubricant and insure proper seating of bearing rollers.
- G. It is recommended that a torque wrench be used for assembly of the adjusting nut. The adjusting nut should be tightened to 45 foot-pound torque while rotating the wheel in both directions. If torque wrench is not available, tighten adjusting nut with a bar 12 to 15 inches in length pushing down with full arm strength (not body weight) while rotating the wheel in both directions.
- H. On a double nut axle, back off adjusting nut 2 to 2-1/2 holes on the lock ring or 1/4 of a turn.
- I. Double Nut Axle - install wheel bearing lock washer and jam nut and tighten to 250 to 300 foot-pounds torque. If a torque wrench is not available, tighten jam nut with a 12 to 15 inch bar with full body weight. The wheel should rotate easily but not have excessive play.
- J. Check final bearing adjustment with a dial indicator. Adjustment should be within 0.001 to 0.008 inch end play. If a dial indicator is not available, check bearing adjustment for play by using pry bar under wheel or tires.

Bearing adjustment may also be checked by rolling torque in inch-pounds. (Multiply pull in pounds by rolling radius from center of axle). Rolling torque should not exceed 55 inch-pounds with grease or 35 inch-pounds with oil.

- K. Should bearings be improperly adjusted, repeat Steps F through I.
- L. Install hub cap with proper gasket. Torque of 16 to 20 foot-pounds is recommended for the cap screws on the hub cap.
- M. If oil is used, fill to line on hub cap, and replace plug.

Step 7: After each run, visually inspect wheels and brake drums for damage or leaks. Keep close check on all moving parts to obtain maximum life.

MATERIAL LIST FOR

WEBB 8315 15" WHEEL ASSEMBLY

<u>PART NUMBER</u>	<u>QUANTITY REQUIRED</u>	<u>DESCRIPTION</u>
8315	1	15" 3-Spoke Wheel
653	1	Inner Bearing Cup
**553X or HM212011	1	Outer Bearing Cup
70655	1	6 Hole Hub Cap
72655	1	Hub Cap Gasket
83175	6	5/16-18 X 3/4 Hex Head Cap Screw(H.C.)
103	6	5/16 Lock Washer
*	1	Brake Drum
96218	6	5/18-18 X 1 3/4 Hex Head Cap Screw(B.D.)
126	6	5/8 Lock Washer
171027	6	3/4-10 x 2 7/8 Stud
74710	6	3/4-10 Hex Nut
+3314 or 3319	3	15" Rim Clamp
+41533 or 41540	1	15 X 3 3/8 Rim Spacer 15 X 4 Rim Spacer
* Brake Drums:		
62358	12 1/4 X 5 1/2	
62368	12 1/4 X 5 1/2(H.D.)	
63617	12 1/4 X 7 1/2	
63647	12 1/4 X 7 1/2(H.D.)	
		+Rim Clamp: The 3314 rim clamp is used with the 41540 rim spacer and the 3319 rim clamp is used with the 41533 rim spacer.

** Outer Cup Bearing: Please check the outer cone and cup number on your wheel before ordering replacements. The 553X cup used with the 560 cone, and the HM212011 cup is used with the HM212049 cone.

<u>No.</u>	<u>Part No.</u>	<u>Description</u>	<u>Qty.</u>
1	3-762-010013	Undercarriage	1
2	3-762-010029	Undercarriage for trailer w/combine wells	1
3	3-762-010027	Bracket, mud flap	2
4	3/4-10 NC x 1½	Hex head bolt	2
	3/4-10 NC x 2½	Hex head bolt	2
	3/4	Lock washer	4
5	3-762-010016	Hold down, undercarriage	4
6	RRT 114-5.75	Roller	2
7	3-762-010012	Roller pin	2
	5010	Grease zerk SAE ¼	4
8	H-128-SW	Cam follower H. D.	4
9	2-12 NC	Hex nut	4
10	3/8-16 NC	Hex nut	8
11	3/8	Lock washer	8
12	3-485-010001	Mud flap	2
13	3-762-010017	Clamp, mud flap	2
14	3/8-16 NC x 3	Hex head bolt	8
15	3-557-010047	Pin, cyl. anchor	1
16	0600-375-04000	3/8 x 4 roll pin	2
17	516-22 PTL	Pin	2

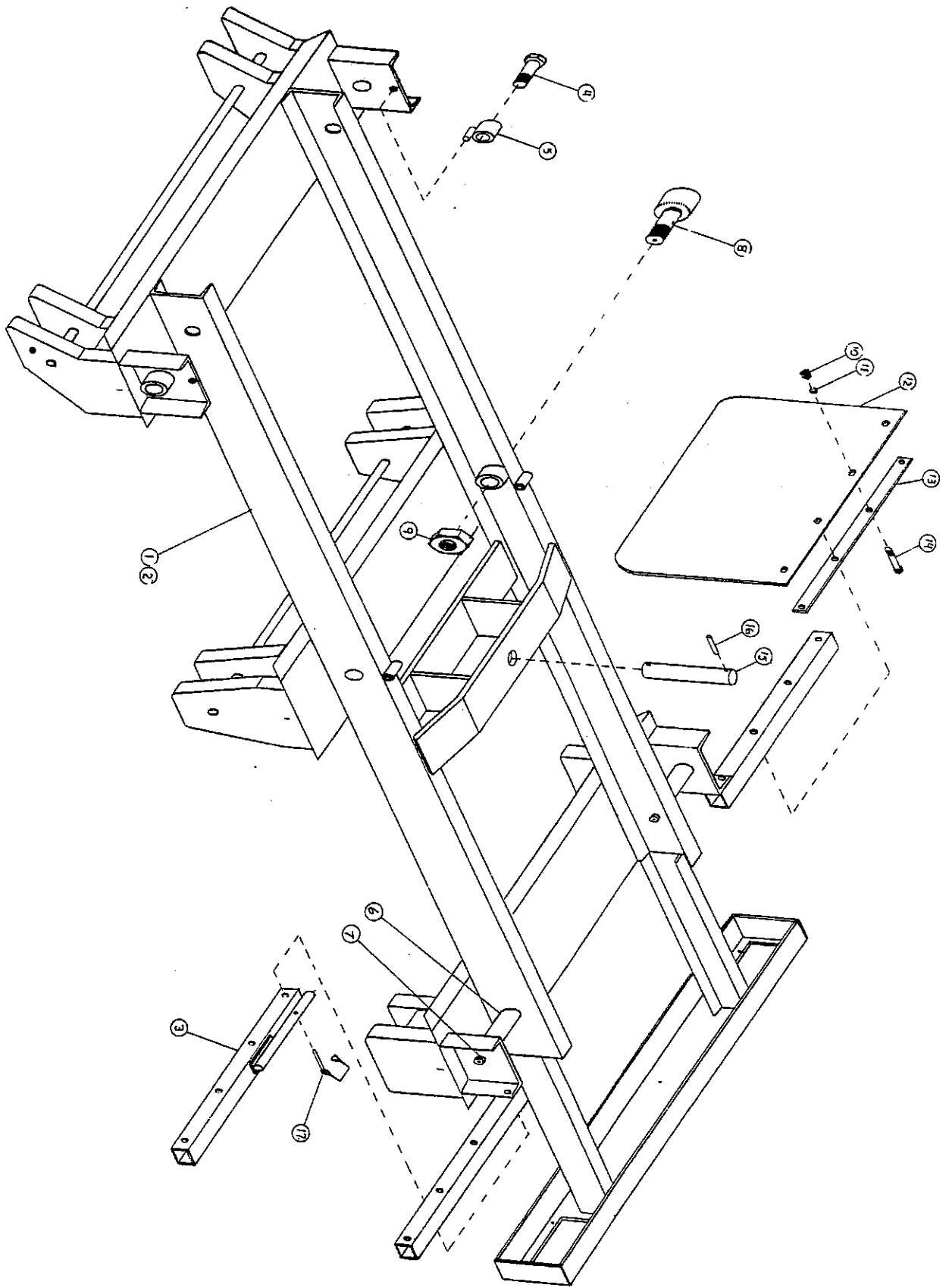

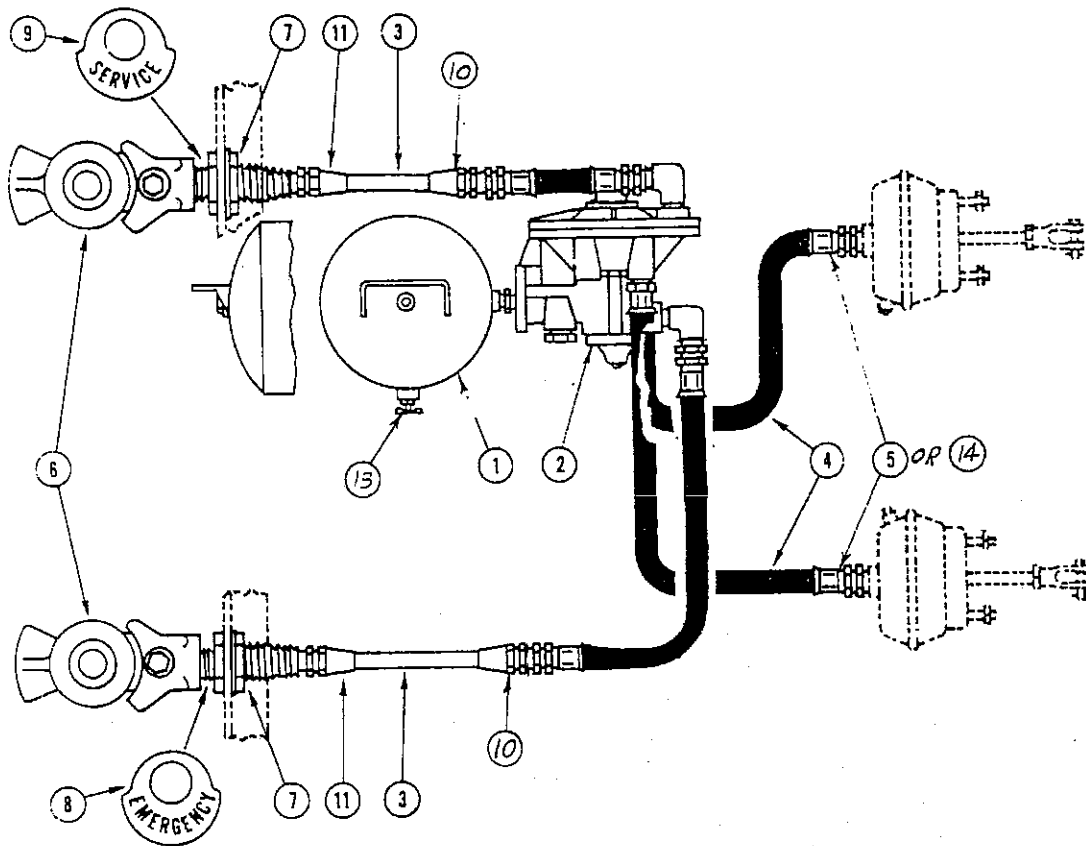

Air Brakes

<u>Item</u>	<u>Part Number</u>	<u>Description</u>	<u>Qty.</u>
1	55D-74	Tank	1
2	32A-319 3190wid	Relay valve	1
3	62P-6	3/8" O.D. nylon tubing	Specify length req'd.
4	54A-6X-250S ✓	Air hose 3/8 I.D. x 3/4 O.D.	Specify length req'd.
5	55C-31	Hose fitting 3/8 hose x 1/4 MPT	As req'd.
6	55B11	Coupler, air, glad hand	2
7	55B-61	Frame union	2
8	55B-61-6	Tag, emergency line	1
9	55B-61-7	Tag, service line	1
10	H0-166-6X 2 4	Connector 3/8 tube x 1/4 FPT	2
11	H0-168-6X 2 4	Connector 3/8 tube x 1/4 MPT	2
12	H0-159- 108 108	Insert (3/8 tube) (Not shown)	4
13	56D-4	Drain cock	1
14	55C-21	Hose fitting 3/8 hose x 3/8 MPT	As req'd.

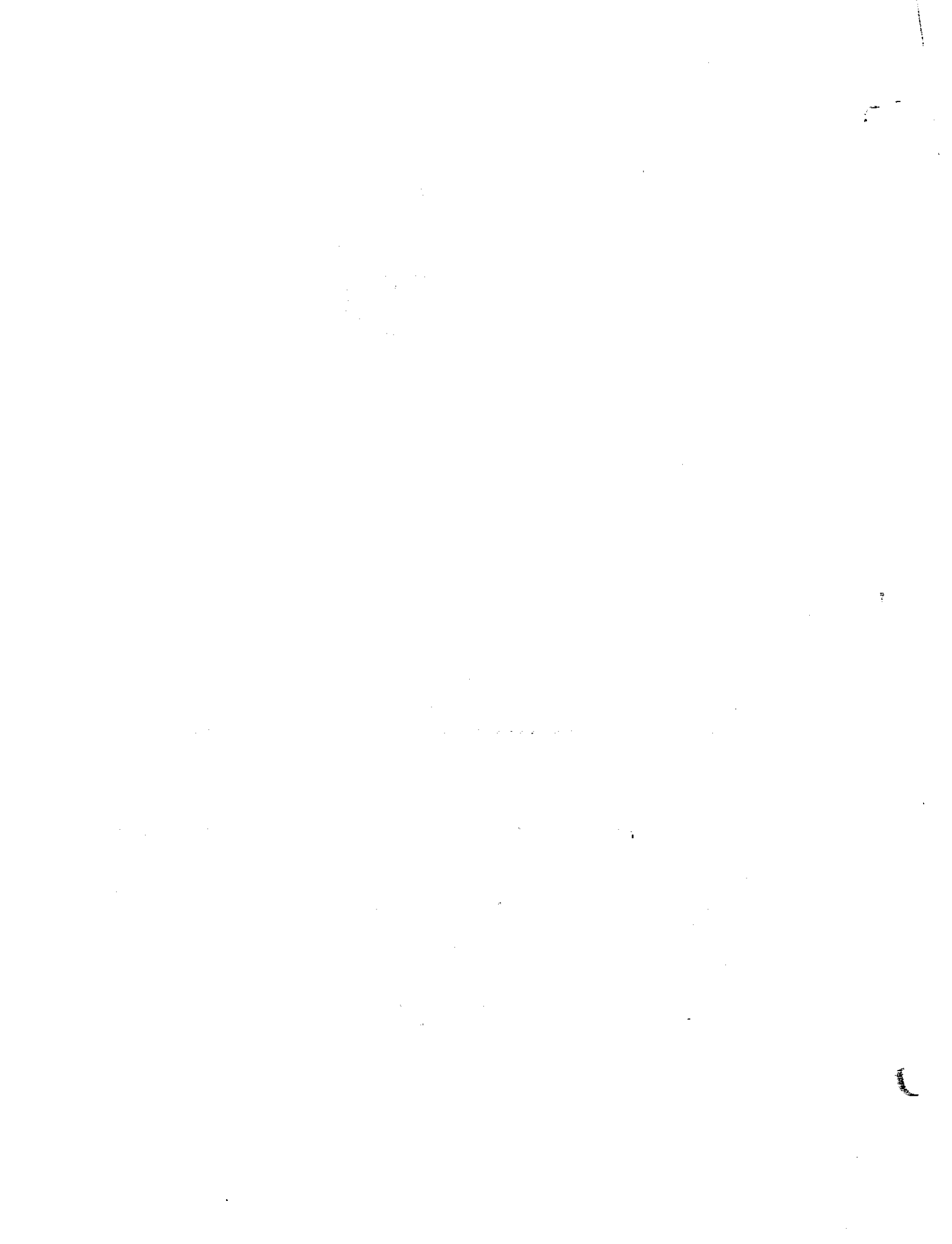

LHA5 HYDRAULIC SYSTEM

ITEM	PART NO.	DESCRIPTION	QTY.
1	4050-4	Coupler body half	1
2	7/8"	Machine bushing	4
3	1/2"	Garden hose washer	2
4	95	Knob, ball	3
5	3-360-010006	Control arm, hyd. valve	3
6	1/8" x 1"	Cotter pin	3
7	BA3-111-AAA-G00AO	3 spool valve	1
	3/8-16 NC x 2	Hex head bolt	3
	3/8-16 NC	Hex nut	3
	3/8"	Lock washer	3
8	2045-8-8S	Swivel adapter	4
9	2049-8-8S	45° swivel adapter	4
10	3/4 x 1/2	Reducer bushing	2
11	2254-8-8S	Tee swivel adapter	1
12	3/16 x 2 1/4	Cotter pin	5
13	3-557-010008-5g	Pin, cyl. rod end	2
14	R-964	4" x 42" hyd. cylinder	2
15	2255-8-8S	Tee swivel adapter	1
** 16	103-1027-007	Hyd. motor	1
17	2047-8-8S	90° swivel adapter	9
* 18	3-762-010021	Cylinder, modified	1
	Includes (1)	K-797 hyd. cylinder	
	and (1)	3-762-010020 end piece, cyl. rod	
19	5010-4 8210-4	Male tip	1
20	Note 1	Hose assy. (press)	1
21	Note 1	" " (return)	1
22	Note 1	Hose assy.	1
23	Note 1	Hose assy.	1
24	Note 1	Hose assy.	1
25	Note 1	Hose assy.	1
26	Note 1	Hose assy.	1
27	Note 1	Hose assy.	1
28	Note 1	Hose assy.	1
29	3-557-010033	Pin, cyl. butt end	3
30	Note 1	Hose assy.	1
31	Note 1	Hose assy.	1
* 32	1/2 NC x 3"	Hex head bolt	1
* 33	3-762-010019	Cyl. rod support	1
* 34	1/2"	Lock washer	1
* 35	1/2 NC	Hex nut	1
36	2832-24	Brass bushing	1

* Used on models through May 1977. Models built after this date will have standard K-797 126" cylinder with drilled cylinder rod, ~~3-762-010033~~ cylinder rod support, ~~3-557-010008~~ pin and ~~3/16 x 2 1/4~~ cotter pin.

Note 1 When ordering hydraulic hose assy., specify length and size of hose required.

** Optional Hyd. motor 104-1003-003, requires additional fittings 2 each of 2066-8-10S swivel adapter.

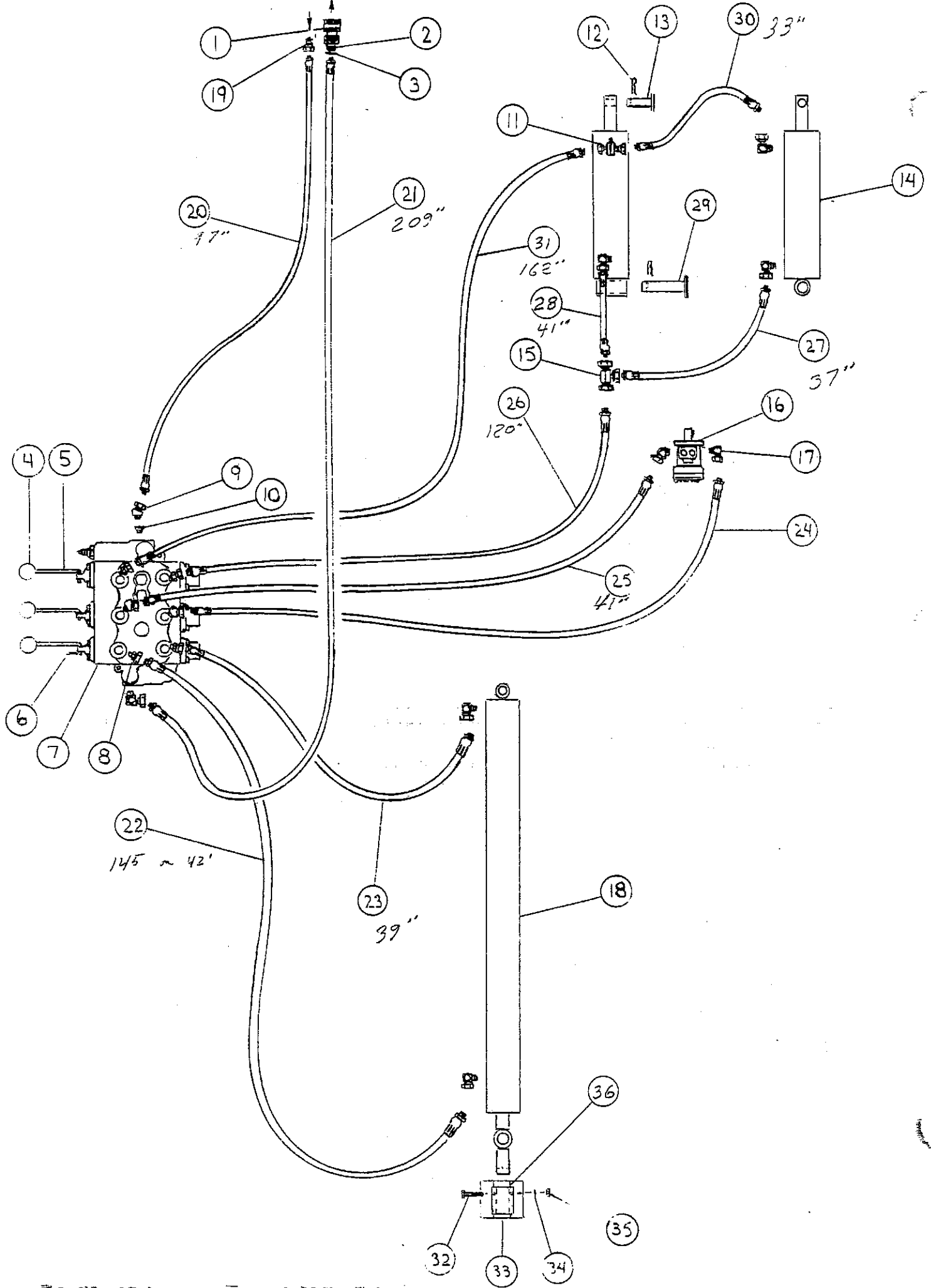

V20-1P13P-1C-11

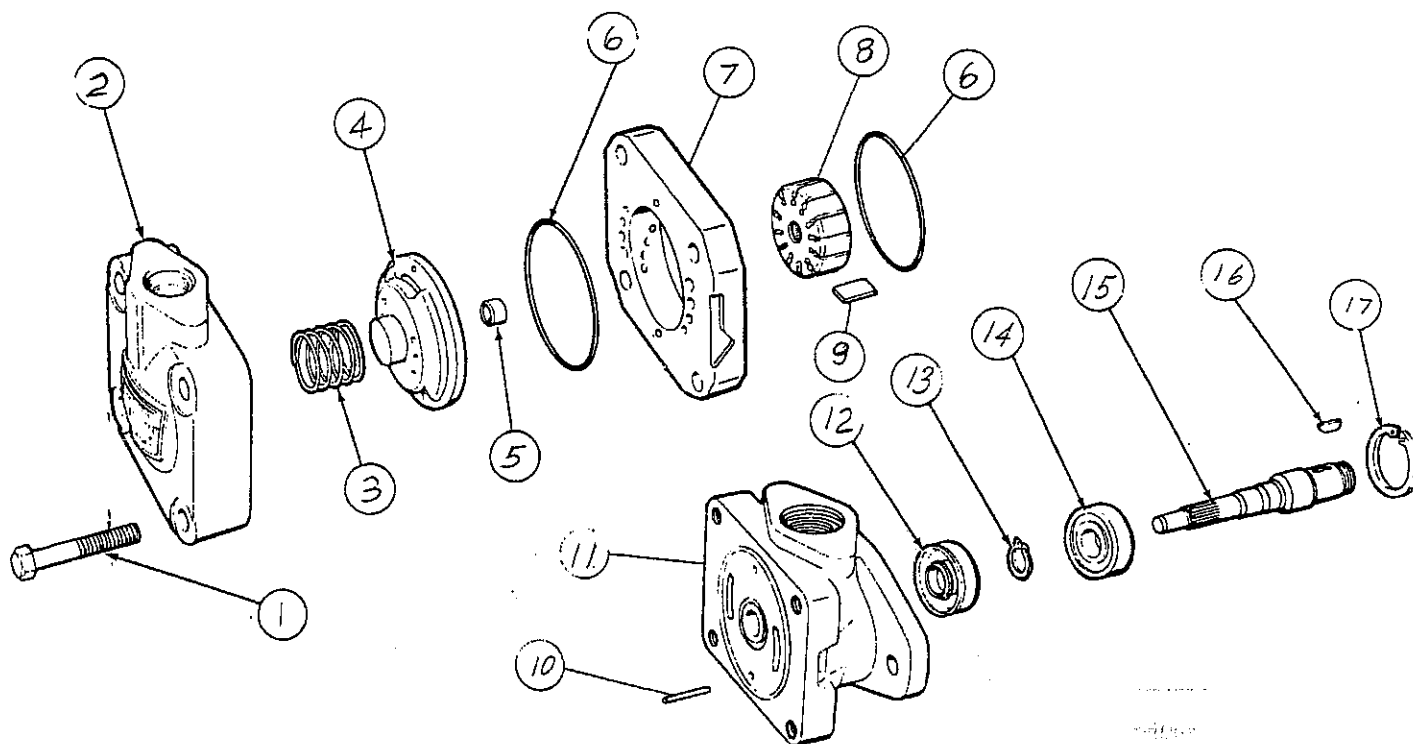

<u>Item</u>	<u>Part No.</u>	<u>Description</u>	<u>Qty.</u>
1	1319	Screw	4
2	313657	Cover	1
3	275672	Spring	1
4	359287	Pressure plate	1
5	280267	Bushing	1
6	154090	"0" ring	2
7	331807	Ring	1
8	358334	Rotor	1
9	923479	Vane kit (12 vanes)	1
10	9603	Pin	2
11	280689	Body	1
12	229235	Seal	1
13	98653	Snap ring	1
14	98574	Bearing	1
15	280372	Shaft	1
16	5881	Key	1
17	109975	Snap ring	1
	922733	Seal kit	
		includes items 6 and 12.	
	923487	Cartridge kit	
		includes items 6, 7, 8 and 9.	



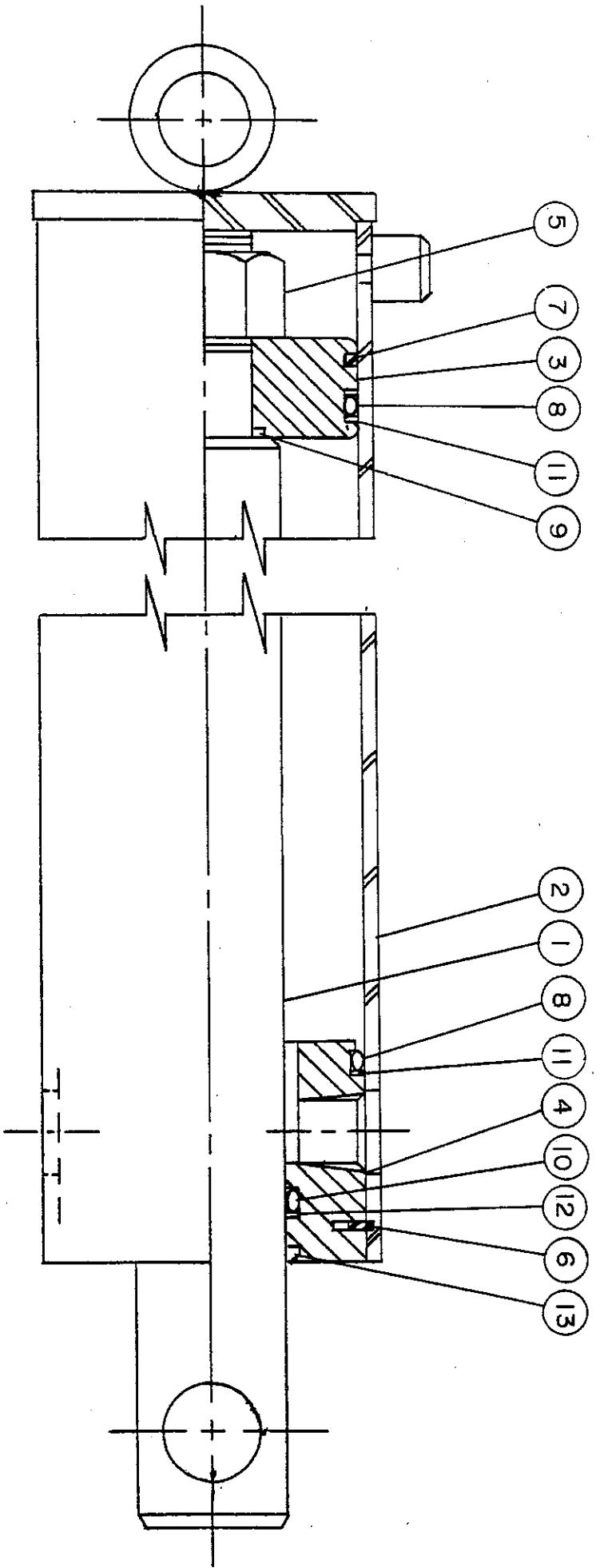

R - 964 HYD. CYLINDER 4 X 42

ITEM	QTY.	PART NO.	DESCRIPTION
1	1	011100080	PISTON ROD
2	1	061900250	BUTT TUBE ASSY.
3	1	071900019	PISTON
4	1	081900019	GLAND
5	1	2200000212	LOCK NUT
6	1	2300001400	SNAP RING
7	1	2400004008	PISTON RING
8	2	2400000342	O-RING
9	1	2400000026	O-RING
10	1	2400000329	O-RING
11	3	2400005342	BU - WASHER
12	1	2400005329	BU - WASHER
13	1	250001329	WIPER
* PMCK - R - 964			PACKING KIT

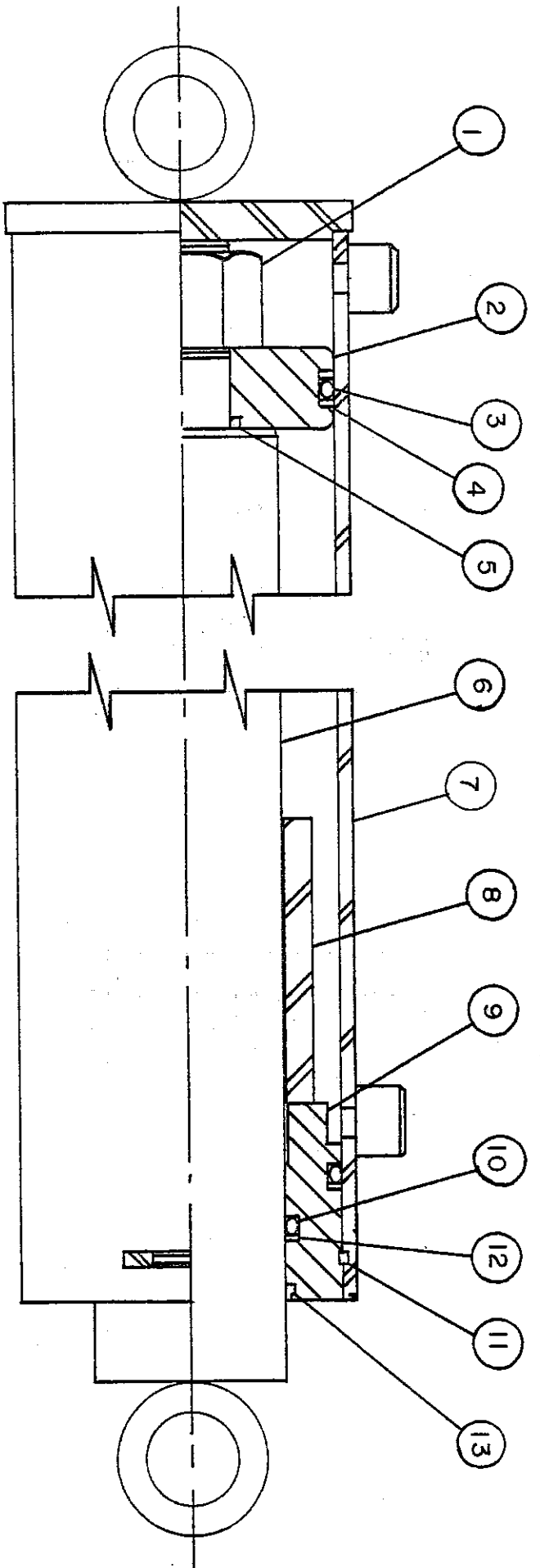

K-797 HYD. CYLINDER 4 X 126

ITEM	QTY.	PART NO.	DESCRIPTION
1	1	220000212	LOCK NUT (1 1/4 - 12)
2	1	071900003	PISTON
3	2	* 2400000342	O-RING
4	3	* 2400005342	BU-WASHER
5	1	* 2400000026	O-RING
6	1	**0213000035	PISTON ROD ASSY.
7	1	061900138	BUTT & TUBE ASSY.
8	1	211300024	SPACER
9	1	081900042	GLAND
10	1	* 2400000333	O-RING
11	1	* 2300007400	SQ. RETAINING RING
12	1	* 2400005333	BU-WASHER
13	1	* 2500001333	WIPER
		* PMCK-K-797	PACKING KIT

** Use 011300179 piston rod on models after June 1977. This rod does not have bushing on end.



PRINCE MANUFACTURING CORPORATION P.O. Box 537 Sioux City, Iowa 51102 Ph. 712 277 4061

December 4, 1974

DISASSEMBLY AND REASSEMBLY INSTRUCTIONS
SPIN-IN RING RETAINER

With the cylinder removed from the machine, retracted, and drained of oil, proceed as follows:

1. Secure the cylinder in a vise or other method to prevent rotation. Rotate cylinder so the slot in barrel is positioned for easy access.
2. With a 90° pin type spanner wrench rotate gland counter-clockwise. The tail end of the wire will appear in slot of barrel. If tail of wire catches it may be necessary to lift wire slightly with narrow screwdriver. Continue rotating gland to feed wire completely out.
3. Pull on piston rod to remove gland and piston from tube. Note: If seals catch in retaining ring groove, it may be necessary to cut seal through slot in tube and pull out with needle-nose pliers.

Before reassembly check that new seals have been installed and all internal parts are free of visible contamination. Smear a heavy grease on piston and gland O.D. seals for easier assembly.

1. Insert piston, gland and rod assembly into tube. Line up hole in gland retaining groove with slot in cylinder barrel.
2. Using new retaining wire rotate gland clockwise until wire is completely in tube.

The cylinder is now ready for reassembly in machine.

DISASSEMBLY AND REASSEMBLY DIAGRAM
SPIN-IN RING RETAINER

NOTE:
1. PUSH TAIL OF RING TOWARD CYLINDER TO AVOID
SCRAPING OF RING ON MILLED SLOT.

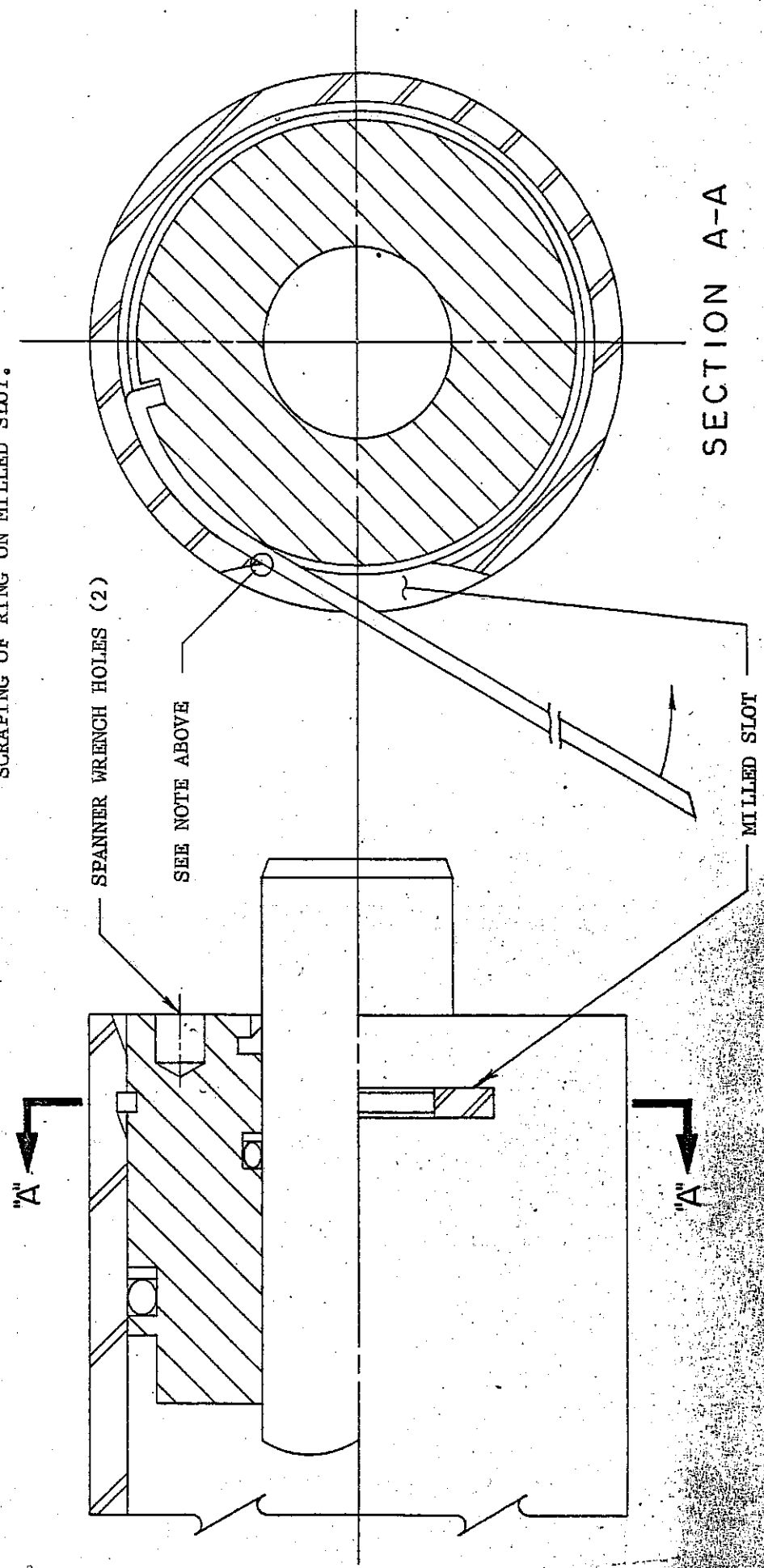

SECTION A-A

BA3 III AAAG00AO

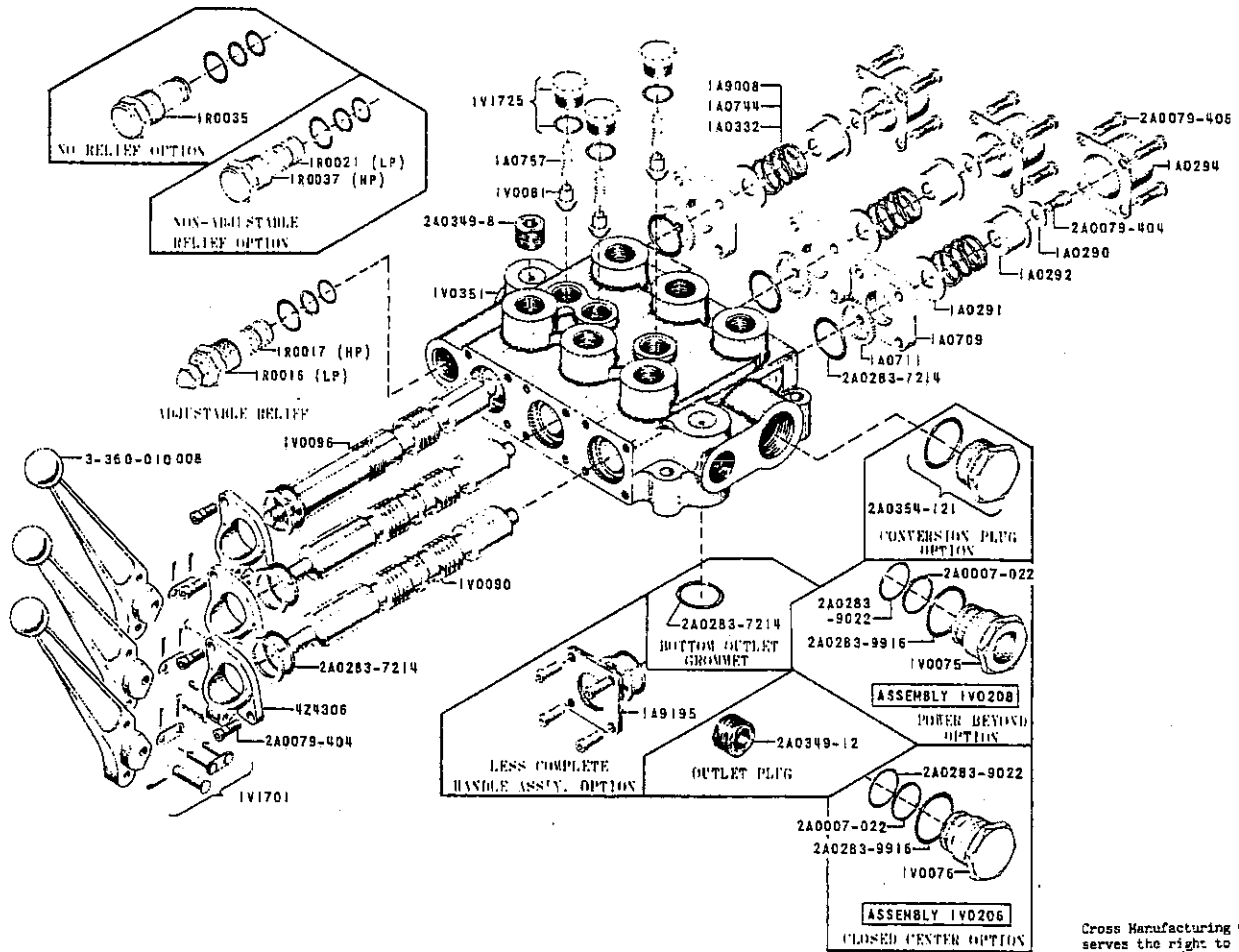

Cross Manufacturing Company reserves the right to discontinue products and/or to change design, specifications or prices at any time without incurring any obligations.

PARTS LIST

PART NO.	DESCRIPTION	QTY. REQ'D. (3-Spool)	PART NO.	DESCRIPTION	QTY. REQ'D. (3-Spool)
1V0081	Load Check Poppet	3	1V0092	4-Way Motoring Spool	Opt.
* 1V0090	4-Way Spool	3	1V0093	3-Way Motoring Spool	Opt.
* 1V0096	3-Way Spool	Opt.	— SPECIAL PARTS FOR LESS COMPLETE HANDLE ASS'Y. OPTION —		
* 1V0101	Valve Housing (1 Spool)		1A9195	O-Ring Retainer Plate	1
* 1V0126	Valve Housing (2 Spool)		— SPECIAL PARTS FOR HIGH PRESSURE RELIEF OPTION —		
* 1V0351	Valve Housing (3 Spool)		1R0017	Relief Ass'y. Adj. (1500-3000)	1
1V1701	Pin Kit	1	— SPECIAL PARTS FOR NON-ADJUSTABLE RELIEF OPTION —		
3-360-010008	Handle	3	1R0021	Relief Ass'y. (500-1500)	Opt.
1V1725	Load Check Plug Ass'y.	1	1R0037	Relief Ass'y. (1500-3000)	Opt.
1R0016	Relief Ass'y., Adj. (500-1500) Std.	3	1R0035	Relief Plug Ass'y.	1
424306	Handle Bracket	3	— SPECIAL PARTS FOR POWER BEYOND OPTION —		
1A0290	Centering Spring Washer	3	1V0076	Power Beyond Sleeve (3NPTF)	1
1A0291	Stop Washer	3	2A0007-022	O-Ring Back-Up	1
1A0292	Stop Collar	3	2A0283-9022	O-Ring	1
1A0294	End Cap	3	2A0283-9916	Plug O-Ring	1
1A0332	Light Centering Spring	Opt.	— SPECIAL PARTS FOR CLOSED CENTER OPTION —		
1A0709	End Spacer	3	1V0076	Closed Center Plug	1
1A0711	O-Ring Spool Washer	6	2A0007-022	O-Ring Back-Up	1
1A0744	Centering Spring (Std.)	3	2A0283-9022	O-Ring	1
1A0757	Load Check Spring	3	2A0283-9916	Plug O-Ring	1
1A9008	Heavy Centering Spring	Opt.	— MISCELLANEOUS —		
2A0079-404	Machine Screw	9	2A0283-7214	Rubber Grommet (Bottom Outlet)	1
2A0079-406	Machine Screw	12	2A0349-8	3/8NPTF, 3-Way Port Plug	Opt.
2A0283-7214	Spool Seal	6	2A0349-12	3/8NPTF Outlet Plug	Opt.
			2A0354-121	Conversion Plug Ass'y. (Opt.)	1

* The select-fit honing process at factory, which fits a spool to an individual valve body, eliminates the possibility of ordering the valve body or spool as separate items.

(#) SEE FORM 101



<u>Item</u>	<u>Part No.</u>	<u>Description</u>	<u>Qty.</u>
1	3-786-010001	Hyd. tank assy. (12.5 gal.)	1
2		1" NPT x 90° st. el	2
3		1" NPT nipple, close	1
4	29857-6	Y-type line strainer	1
5	3-561-010001	Hose barb 1" NPT	2
6	4-1203	Hose clamp 1 1/4-1 3/4	2
7	See Note I	hose assy.	1
8	2047-8-8S	90° swivel adapter	3
9	3/4 x 1/2	Reducer bushing	1
10	201P13P1C11	Pump, Vickers	1
11	1 1/2 x 1	Reducer bushing	1
12	19B-60	Hose 1 1/4" x 5' long	1
13	RD12D	Hydraulic relief valve	1
14		3/4" NPT nipple, close	1
15		2" pipe plug	1
16	See Note I	hose assy.	2
17	5010-4	Male tip	1
18	4050-4	Coupler body half	1

Note I, when ordering hydraulic hose assy., specify length and size of hose required.

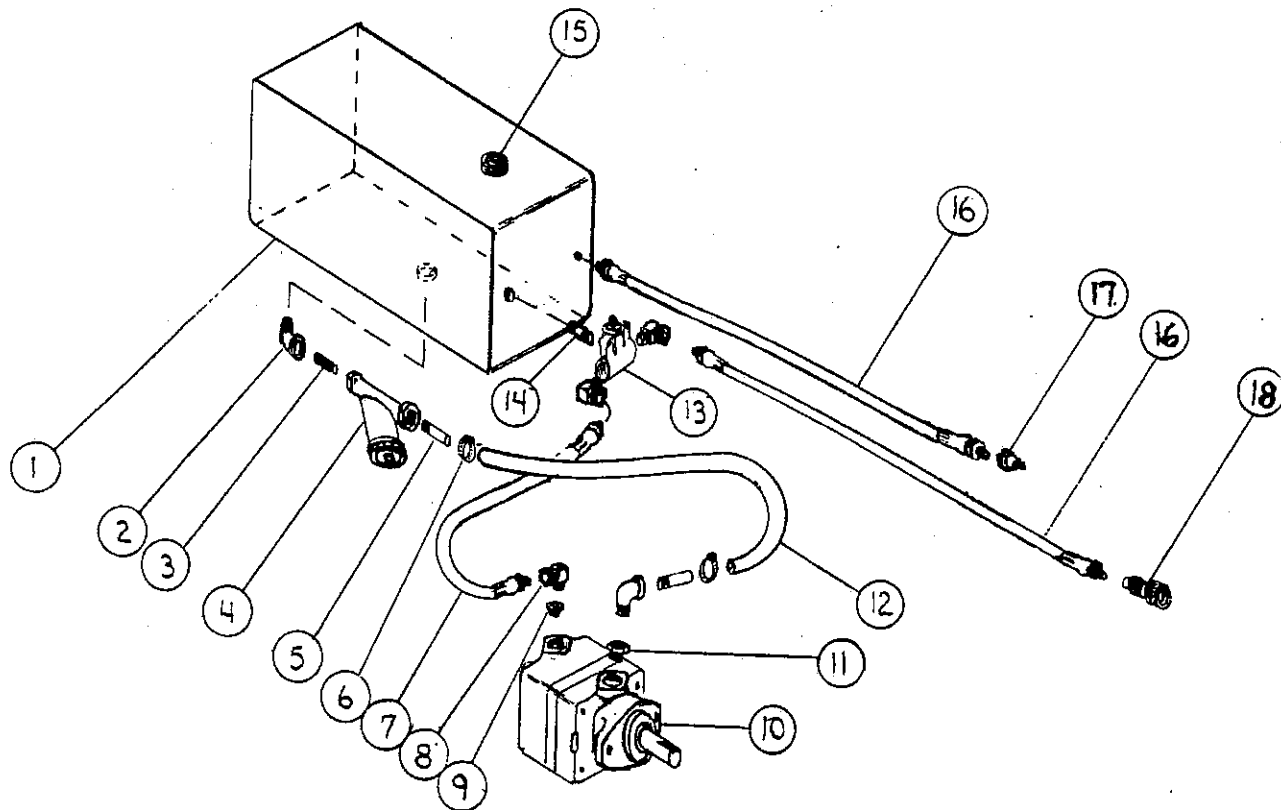

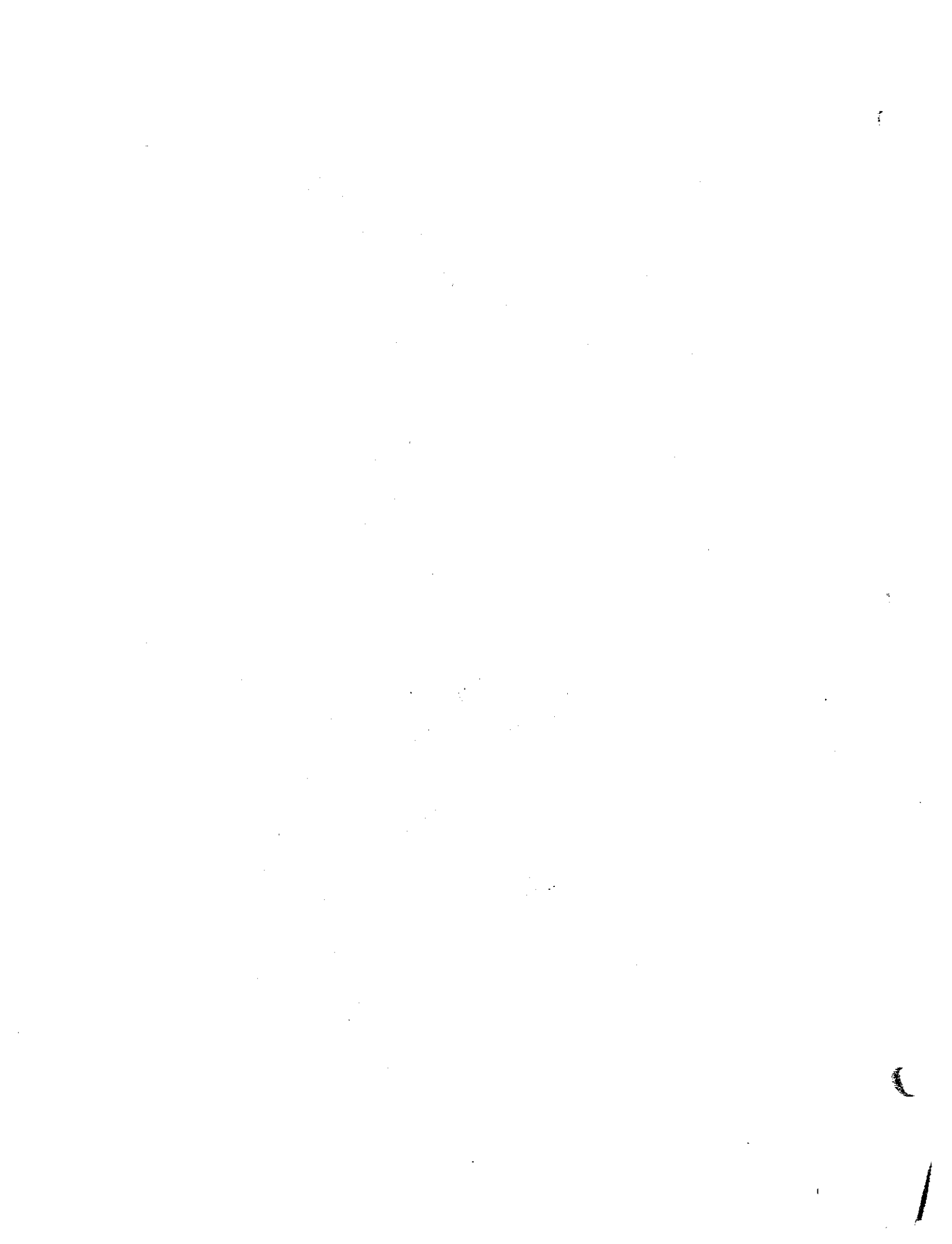

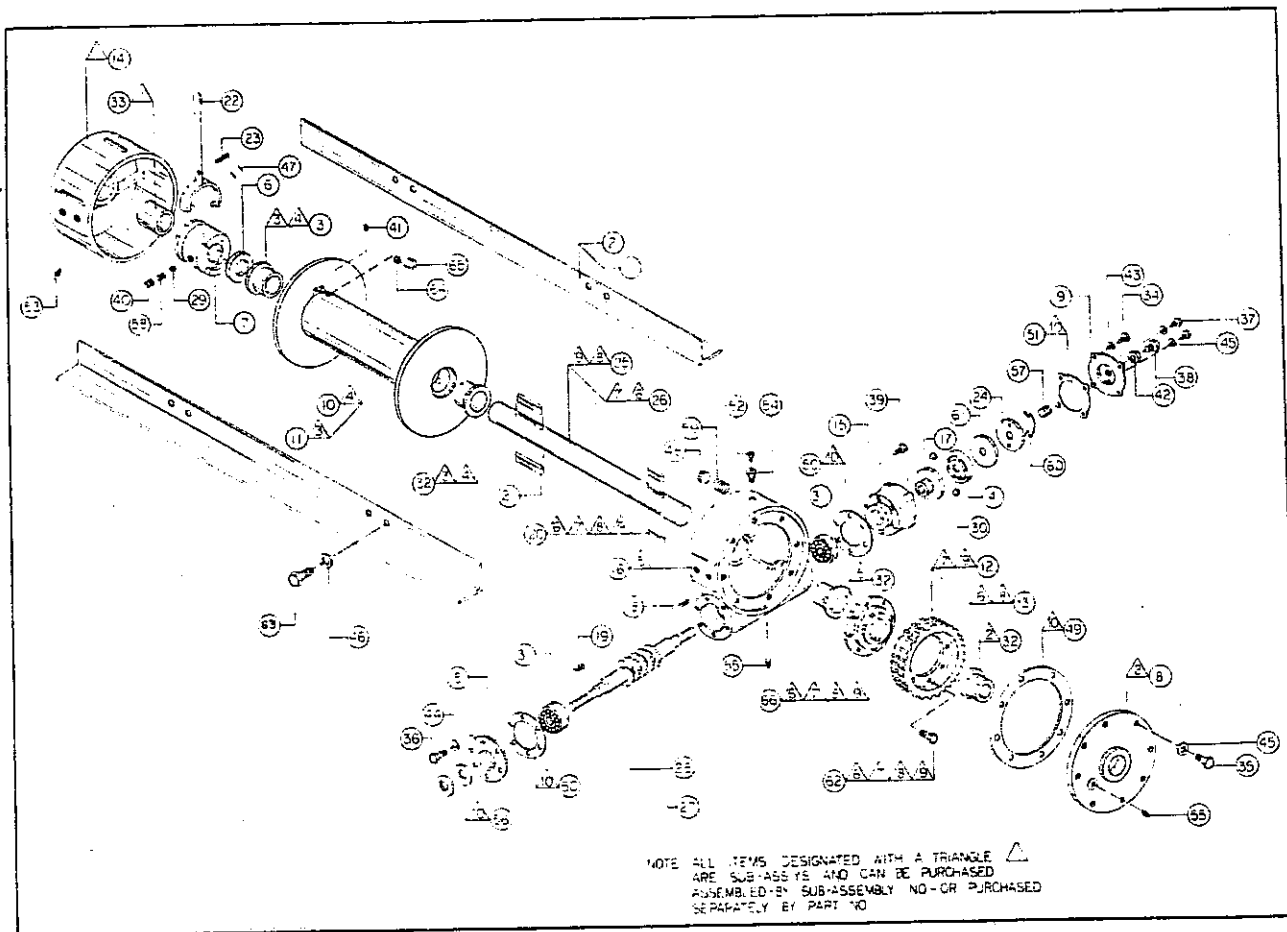

MATERIAL LISTING

ITEM NO.	QTY REQ	PART NO.	DESCRIPTION	ITEM NO.	QTY REQ	PART NO.	DESCRIPTION	ITEM NO.	QTY REQ	PART NO.	DESCRIPTION
1	2	302093	Angle (Y800)	24	1	352021	Plate	47	2	424005	Cotter Pin
2	2	302111	Angle Std.	25	1	356728	Drum Shaft (Y800)	48	2	438001	Drag Brake
3	1	308049	Bushing	26	1	356770	Drum Shaft - Std.	49	1	442033	Gasket
4	1	314007	Cam Plate	27	1	368082	Worm R.H.	50	2	442093	Gasket
5	1	316006	End Plate	28	1	368084	Worm L.H.	51	1	442095	Gasket
6	1	324010	Spacer	29	1	400003	Ball	52	1	456008	Relief Fitting
7	1	324103	Jaw Clutch	30	2	400007	Ball	53	1	456031	Lub Fitting
8	1	328019	Cover	31	2	402045	Bearing	54	1	468002	Reducer
9	1	328027	Brake Cover	32	3	412009	Bushing	55	2	468011	Pipe Plug
10	1	332019	Drum (Y800)	33	1	412020	Bushing	56	2	486016	Oil Seal
11	1	332059	Drum Std.	34	4	414071	Capscrew	57	1	494010	Spring
12	1	334083	Gear L.H.	35	8	414234	Capscrew	58	1	494011	Spring
13	1	334086	Gear R.H.	36	6	414282	Capscrew	59	2	494022	Spring
14	1	338020	Clutch Hsg.	37	2	414391	Capscrew	60	1	494025	Flat Spring
15	1	338039	Brake Hsg.	38	1	414574	Capscrew	61	1	530007	Brake Plate
16	1	338084	Gear Hsg.	39	6	414901	Capscrew	62	8	414573	Capscrew
17	1	340011	Brake Hub	40	1	414971	Poppet Screw	63	8	414734	Capscrew
18	1	342053	Key	41	1	416057	Setscrew (Y800)	64	2	418048	Nut (Mod 800 only)
19	1	342092	Key	42	1	418067	Nut	65	1	514006	U-Bolt (Mod 800 only)
20	2	342141	Key	43	4	418162	Lockwasher	66	1	340017	Gear Hub
21	2	342144	Key	44	6	418176	Lockwasher				
22	1	344019	YoKe	45	10	418184	Washer				
23	1	346019	Pin	46	8	418248	Lockwasher				

SUB ASSEMBLY LISTING

ITEM NO.	QTY REQ'D	PART NO.	DESCRIPTION	ITEM NO.	QTY REQ'D	PART NO.	DESCRIPTION
△1	1	222016	Clutch Hsg. Assy.	△6	1	250172	Gear & Shaft Assy. R.H. Std.
△2	1	228020	Cover Assy.	△7	1	250173	Gear & Shaft Assy. L.H. Std.
△3	1	234048	Drum Assy. Std.	△8	1	250174	Gear & Shaft Assy. R.H. (Y800)
△4	1	234071	Drum Assy. (Mod. Y800)	△9	1	250175	Gear & Shaft Assy. L.H. (Y800)
△5	1	248007	Gear Hsg. Assy.	△10	1	246012	Seal & Gasket Kit

Ramsey Winch Co.

5531 EAST ADMIRAL PLACE • PHONE TR 5-1521
BOX 15829, ADMIRAL STATION • TULSA, OKLAHOMA

INSTALLATION INSTRUCTIONS

RAMSEY AUTOMATIC SAFETY BRAKE ASSEMBLY (OIL COOLED)

1. If winch has left hand worm and gear and spools over top of drum, put brake balls in number one slots on cam. If winch spools under drum, put brake balls in number two slots.

If winch has right hand worm and gear and spools over drum, use number two slots in cam for brake balls. If winch is underwind, use number one slots for brake balls.
2. Install brake hub on winch worm with key.
3. Assemble balls in cam using hard grease to hold balls in place.
4. Install cam and balls, fitting balls in slots on hub.
5. Install brake disc.
6. Install retainer.
7. Install flat spring in brake housing cover (arch down).
8. Install brake housing cover, fitting pins in slots on spring and holes in retainer.
9. Test brake by shifting PTO to forward then reverse to see if brake is working in proper rotation. If not, remove brake and locate brake balls in opposite set of slots.
10. Adjust to suit by tightening or loosening screw on outside of cover. When proper adjustment is obtained, secure screw with jam nut.

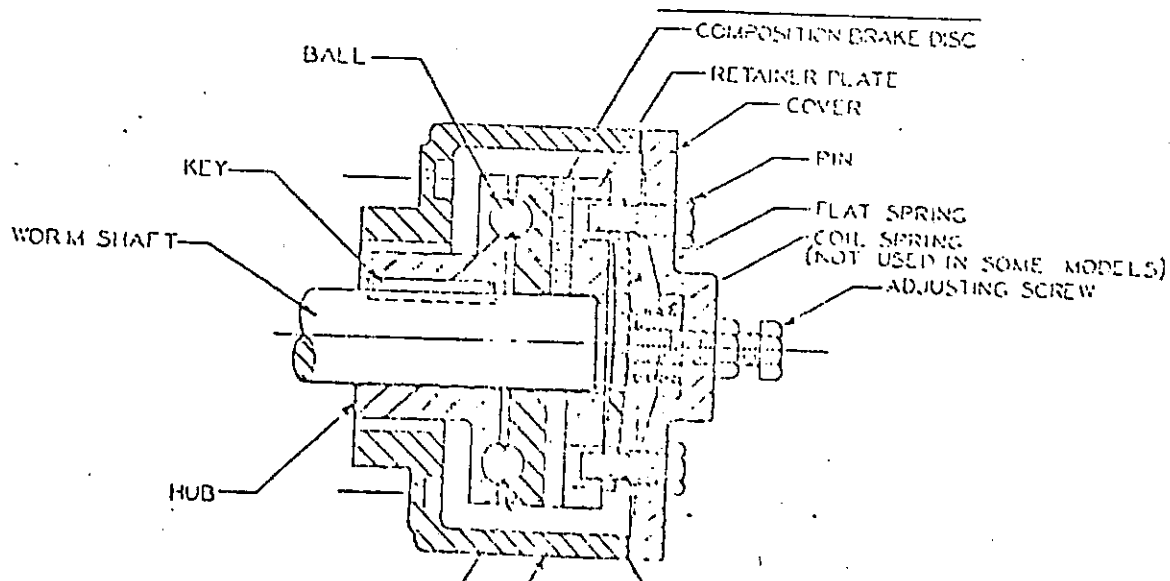
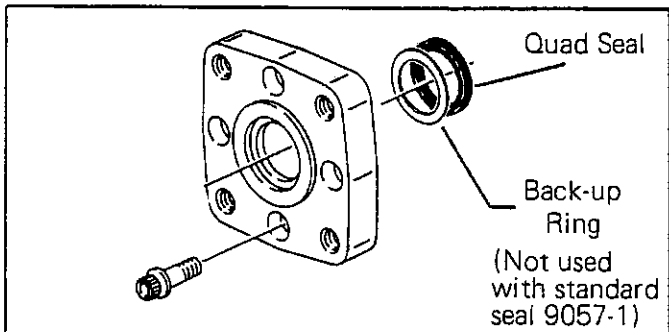
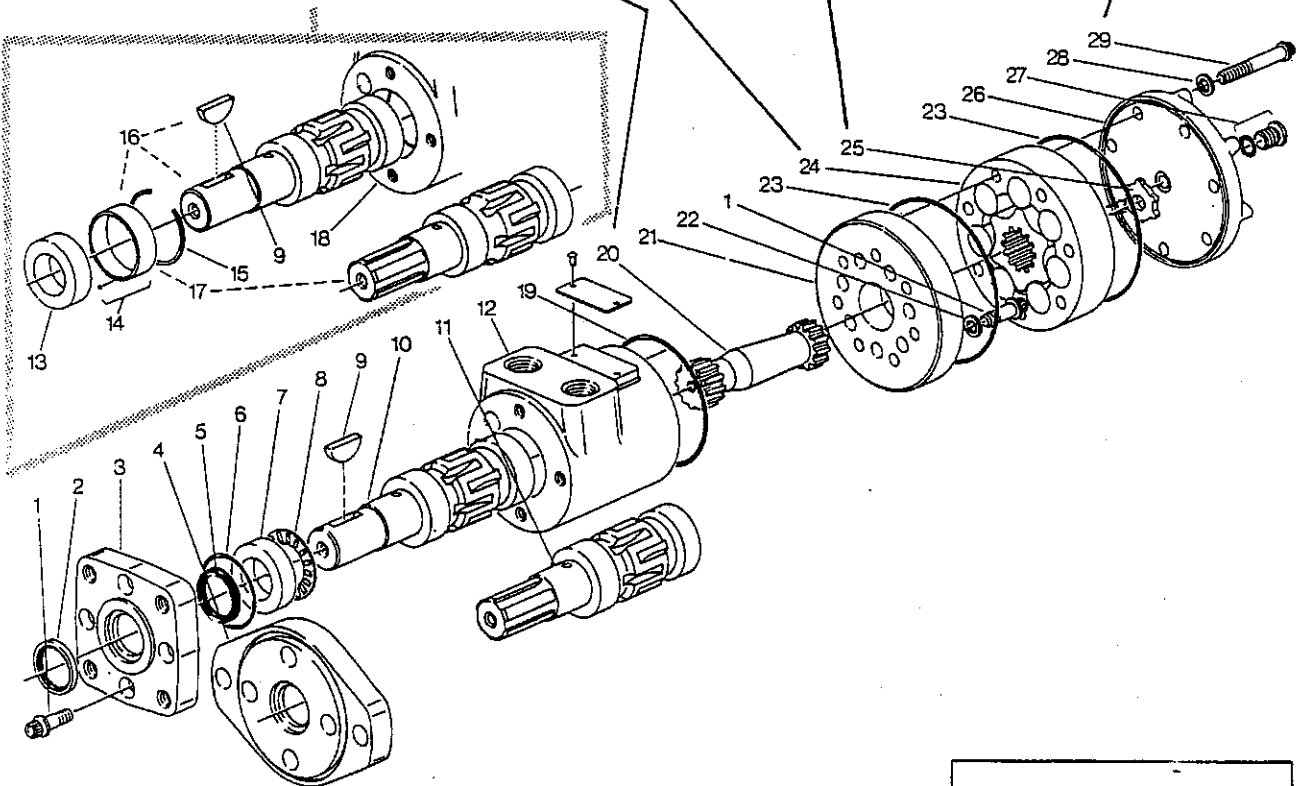

Chart-1

Displacement Cu. In./Rev.	Drive	Geroler	Geroler Width	Spacer	Washer Seal	Cap Screws-- Length
4.3	5741	6606-2	.38"	6901-1	6049	5389-21 - 1.25"
6.0	6610	6606-3	.53"	NONE	6049	5389-9 - 1.38"
9.9	6611	6606-4	.86"	6901-1	N O N E	5389-3 - 1.75"
11.5	6612	6606-5	1.00"	6901-1		5389-10 - 1.87"
14.3	6612	6606-6	1.25"	6901-2		5389-4 - 2.12"
17.2	6612	6606-7	1.50"	6901-4		5389-18 - 2.38"
23.0	6612	6606-8	2.00"	6901-7		5389-19 - 2.87"

Motors With
Optional Bearing



Alternate seal furnished on some models due to unavailability of standard high pressure seal # 9057-1. For replacement purposes always order 9057-1.

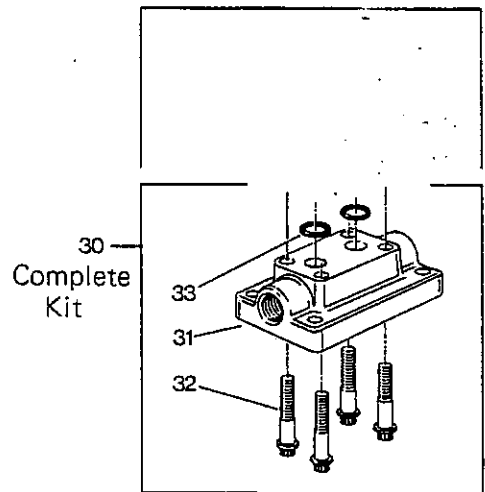

Base Block Mounting Kit

Ref. No.	Part No.	Description	Quantity Req'd.		Recommended spare parts per 100 units.
			Motors With Standard Radial Bearing	Motors with Heavy Duty Radial Bearing	
1	5777	Screw, Cap (12 pt. Dr. 5/16-24 NF x 7/8)	11	11	1 Kit # 60517
X 2	9055-1	Seal	1	1	
3	7464	Flange, Mounting (4 bolt)	1	1	3
4	7463	Flange, Mounting (2 bolt)	1	1	3
X 5	9057-1	Seal	1	1	
X 6	15048	Seal, O-Ring	1	1	
7	7462	Race, Thrust Bearing	1		5
8	7537	Bearing, Thrust, Needle	1		5
9	14193	Key, Woodruff	1		
10	7360-1	Shaft, Straight	1		3
11	7360-2	Shaft, Splined	1		3
12		Housing	1		3
	7359-1	7/8-14 Str. Thd. Ports			
	7359-2	1/2-NPTF Ports			
	7359-3	O-Ring Ports			
13	7593	Race, Thrust, Bearing		1	5
14	60024	Bearing & Ball Kit		1	5
	NSS	Radial Bearing			
	18029	Ball			
15	14326	Ring, Snap		1	5
16	60043	Shaft & Bearing Kit (Keyed)		1	3
	7666-1	Shaft		1	
	14193	Key, Woodruff		1	
	60024	Bearing & Ball Kit		1	
17	60044	Shaft & Bearing Kit (Splined)		1	3
	7666-2	Shaft		1	
	60024	Bearing & Ball Kit		1	
18		Housing		1	
	7592-1	7/8-14 Str. Thd. Ports			2
	7592-2	1/2- NPTF Ports			1
	7592-3	O-Ring Ports			2
X 19	5776	Seal, O-Ring	1	1	
20	*	Drive	1	1	5
21	7458	Plate, Spacer	1	1	3
22	5417	Washer, Lock	11	11	1 Kit # 60515
X 23	15062	Seal, O-Ring	2	2	
24	*	Geroler	1	1	5 ea. displ. size
25	*	Spacer	1	1	3 ea. displ. size
26	6797	Cap, End	1	1	3
27	6833	Plug Assembly	1	1	3
	14236	Plug	1	1	
X	15073	O-Ring	1	1	
X 28	*	Washer Seal	7	7	
29	*	Screw, Cap	7	7	1 Kit ea. displ. size
30	123-1007-001	Base Block Kit-(1/2 NPTF Ports). (Optional on motors with o-ring ports only).			
31	NSS	Port Block	1	1	
32	21046-2	Screw, Cap	4	4	
33	15058	Seal, O-Ring	2	2	
30	123-1008-001	Base Block Kit-(7/8-14 Str. Thd. Ports)(Optional on motors with o-ring ports only).			
31	NSS	Port Block	1	1	
32	21046-2	Screw, Cap	4	4	
33	15058	Seal, O-Ring	2	2	
X	60026	Seal Kit-For all motors Contains parts indicated by X			10

X— Seal Kit (see 60026).

*— See chart 1 for part numbers of specific models.

NSS— Not Sold Separately.

60030	Seal Kit-Ethylene Propylene, —Optional. Formerly Butyl.	Available only as kits for installation by user.
60034	Seal Kit-Viton,—Optional. —Usually preferred for use in systems with higher operating temperatures. For more information contact Service Dept. For use with certain fire resistant synthetic fluids. CAUTION: Check for compatability with fluids before using	

MOTOR ADAPTER FOR LGU2-10F1 WINCH

<u>DESCRIPTION</u>	<u>5 DIGIT NO.</u>	<u>PART NO.</u>	<u>QTY.</u>	<u>ITEM</u>
Motor adapter	23079	23079	1	1
Capscrew 3/8-16NC x 1 3/4			4	7
Coupling half-winch	23081	23081	1	2
Coupling half-motor	23083	23083	1	5
Spacer-constant	23078	23078	1	3
Chain-RLR	13424	701180	1	4
Capscrew 1/2-13NC x 1 1/4			2	6
Lockwasher 1/2"			2	9
Lockwasher 3/8"			4	8

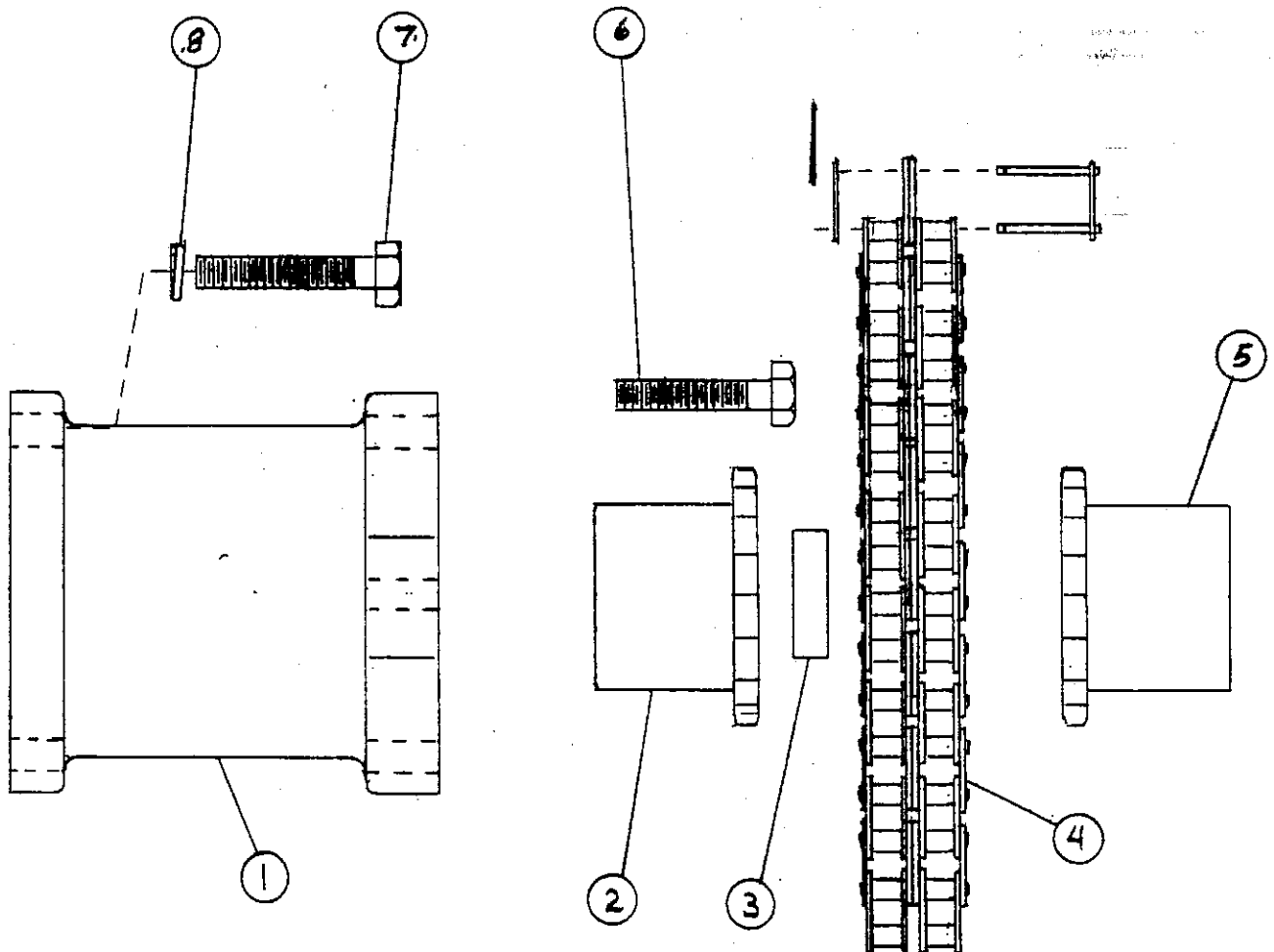

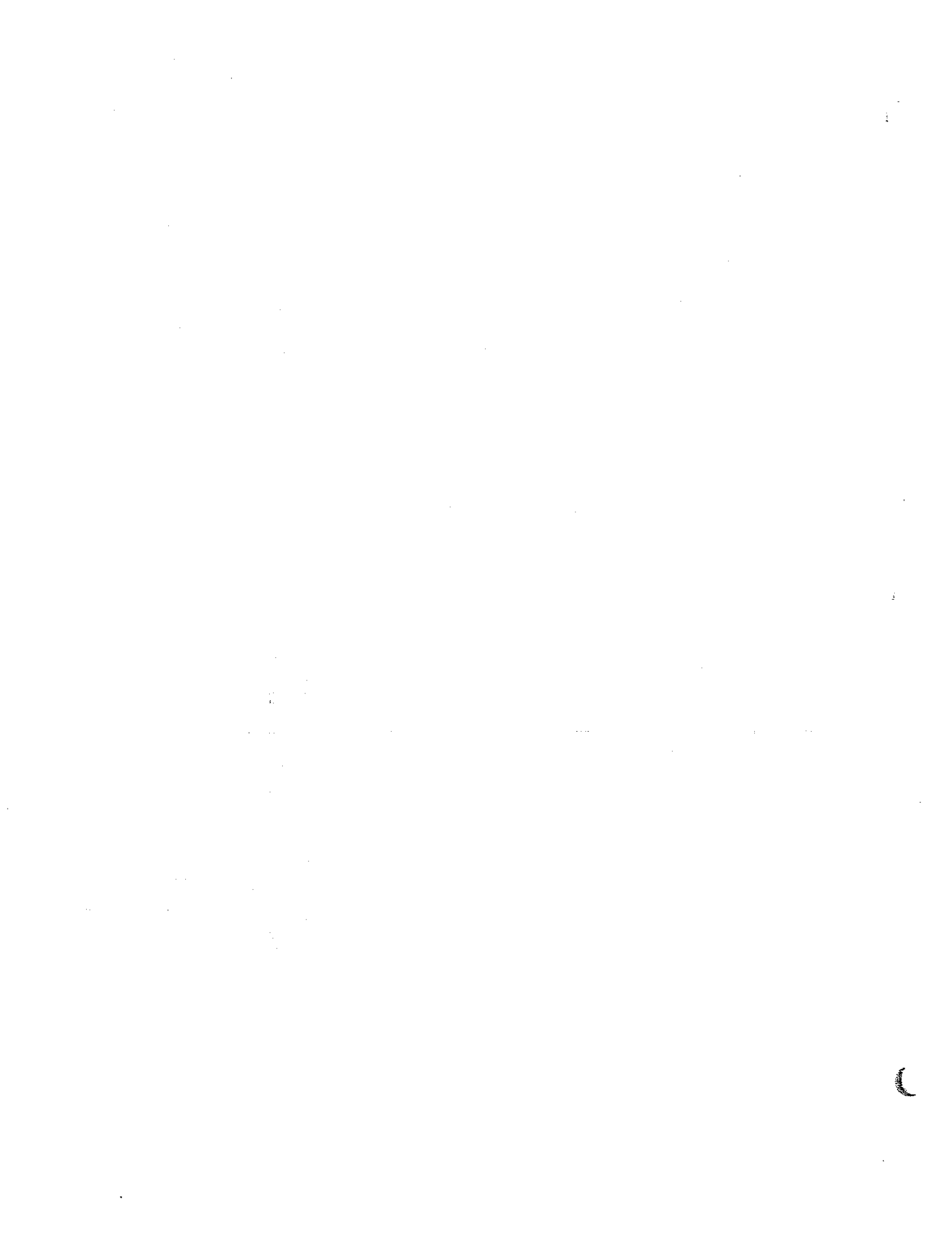

WINCH

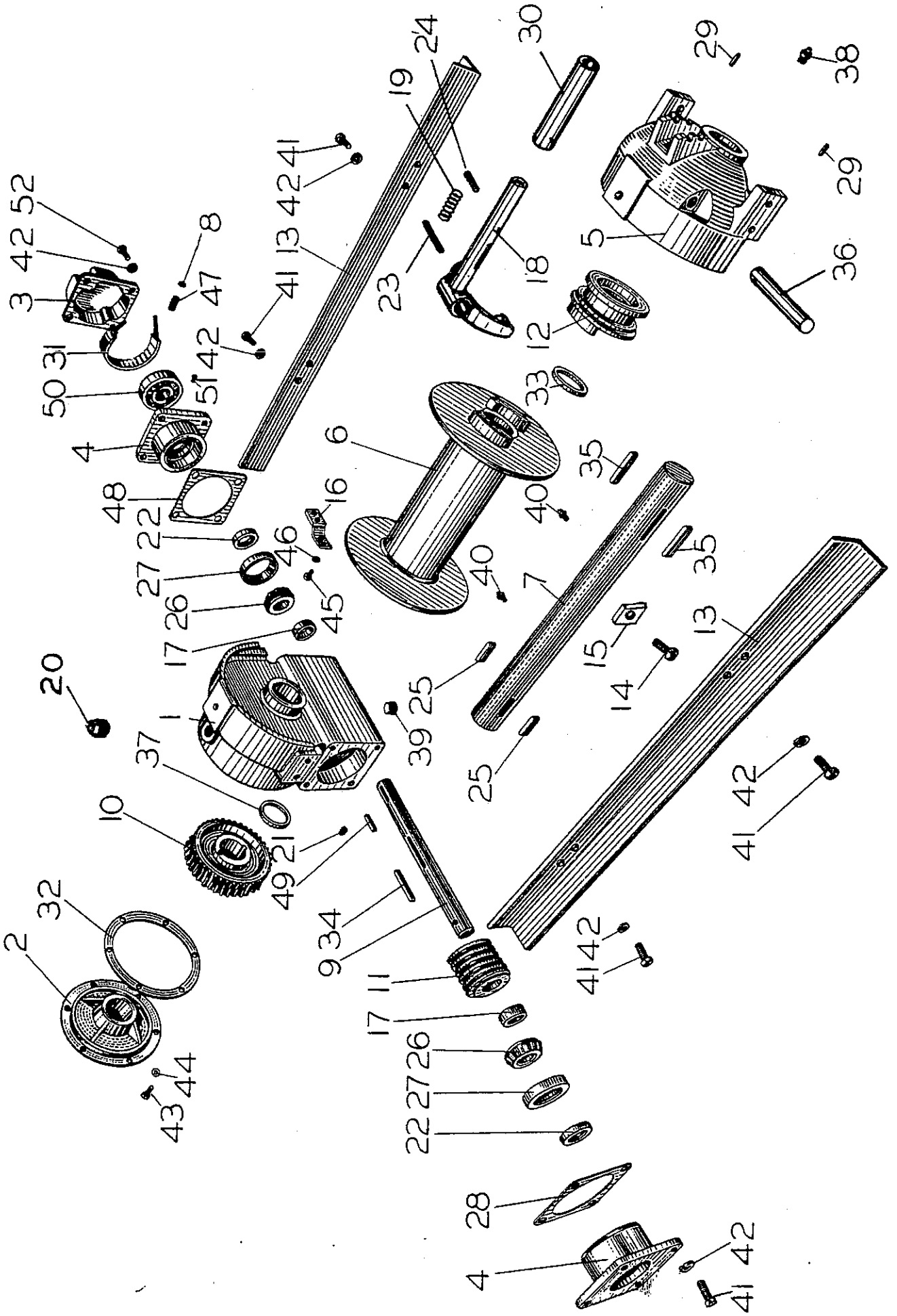

LGU2-10F-1 WINCH 12,000 lb. PULL

<u>ITEM</u>	<u>DESCRIPTION</u>	<u>5-DIGIT NO.</u>	<u>PART NO.</u>	<u>NO. REQ'D.</u>
1	Worm housing assy.	81006	LU2-134-0	1
2	Worm housing cover	81009	LU2-144-0	1
3	Safety brake housing	18032	MU-248	1
4	Bearing container	23303	23303	2
5	Bearing leg assy.	81530	81530	1
6	Cable drum	11128	LU2-135	1
7	Cable drum shaft	11129	LU2-136	1
8	Jam nut	13468	B025J	4
9	Worm shaft	23470	23470	1
10	Worm gear	11144	LU2-201L	1
11	Worm	11142	LU2-200L	1
12	Clutch	18039	M2-141	1
13	Base angle	22752	ALU2-146	2
14	Capscrew	22693	S037-07PH5	1
15	Cable clamp	23462	23462	1
16	Drag brake	81025	LU4-131-0	1
17	Warm spacer	11308	MU-1025	2
18	Shifter fork	13839	LU2-143	1
19	Spring	18002	A-143S	1
20	Pipe plug	22775	E100TD	1
21	Pipe plug	18009	E012T	1
22	Grease seal	18026	MU-149A	2
23	Roll pin	13028	R25-175	1
24	Roll pin	18056	R25-075	1
25	Worm gear key	11117	LU2-101A	2
26	Bearing cone	18015	MU-103A	2
27	Bearing cup	18016	MU-103B	2
28	Gasket	18027	MU-149G	3
29	Roll pin	11837	R12-062	2
30	Shifter handle	12817	LU2-143-3	1
31	Brake band	21925	MU-152-0	1
32	Gasket	11133	LU2-144G	3
33	Retainer ring	18019	MU-139	1
34	Worm key	18030	MU-200A	1
35	Clutch key	18020	MU-141A	2
36	Shifter shaft	11130	LU2-143A	1
37	Thrust ring	11240	MS3-139	1
38	Grease fitting	18047	Z525	1
39	Pipe plug	19045	E050W	1
40	Grease fitting	11799	Z1652	2
41	Capscrew	21961	S037-10PH5	8
42	Lock washer	18003	A037	16
43	Capscrew	11767	S031-10PH5	6
44	Lock washer	11011	AK031	6
45	Capscrew	13005	S025-06PH5	2
46	Lockwasher	12780	AK025	2
47	Spring	18029	MU-156	1
48	Gasket	18024	MU-148G	3
49	Key	18044	M5-151A	2
50	Brake drum	18028	MU-151	1
51	Set screw	12075	S025-03STK	1
52	Capscrew	22703	S037-17PH5	4

<u>Item</u>	<u>Part No.</u>	<u>Description</u>
1	3-276-010152	Right rear overwidth, std.
	3-276-010146	Left rear overwidth, std.
	3-276-010135	Right rear overwidth, combine well
	3-276-010102	Left rear overwidth, combine well
2	3-276-010098	Overwidth w/light opening
3	3-276-010156	Overwidth 41" long
	3-276-010137	Short overwidth 47" long
	3-276-010157	Short overwidth 45 1/4" long
	3-276-010139	Short overwidth 32" long
	3-276-010141	Short overwidth 35" long
	3-276-010155	Short overwidth 39 1/4" long
4	3-276-010051	Extension support
5	3-276-010136	Overwidth extension 71" std.
	3-276-010154	Overwidth extension 59" long
6	3-557-010042	Support tube pin
7	#3	Hairpin
8	3-276-010053	Front extension support left
9	3-276-010054	Front extension support right
10	3/16 x 1 1/4	Cotter pin
11	3-557-010029	Hinge pin, overwidths
12	0600-250-01000	1/4 x 1 roll pin
13	3-869-010008	Support tube, combine wells
14	2-557-010010	Pin
15	3-174-010001	Chain, combine well support
16	516-22PTL	Pin
17	3-869-010007	Support bar, combine well chains
18	3-557-010055	Pin, support bar
19	E0650-063-1750	Spring
20	7/8	Flat washer
21	7/8-9 NC	Hex nut
22	3-276-010077	16" front extension
23	3-276-010049	Front extension support
24	3-557-010038	Pin, front ext. support, lower
25	3-557-010039	Pin, front ext. support, upper
26	3-276-010022	Overwidth extension
27	3-276-010052	Rear overwidth support slide
28	3-869-010004	Right combine well
29	3-869-010005	Left combine well

Note: Some early models and special models may have overwidth variations that are not listed above. If so, please specify length of overwidth and hinge spacing.

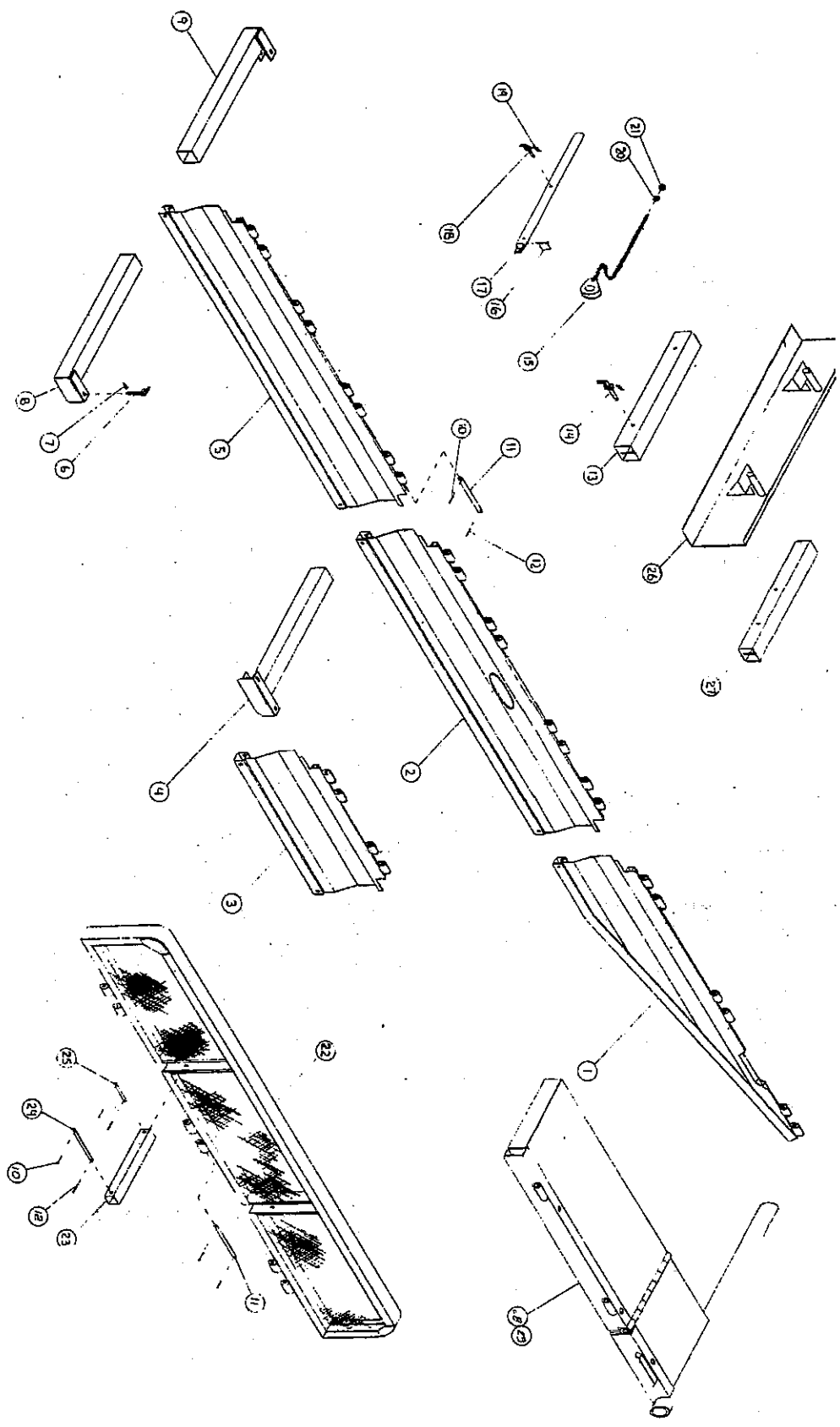

<u>Item</u>	<u>Part No.</u>	<u>Description</u>
1	3-276-010045	Right rear overwidth, std.
	3-276-010046	Left rear overwidth, std.
	3-276-010057	Right rear overwidth, combine well
	3-276-010058	Left rear overwidth, combine well
2	3-276-010043	Right center overwidth
	3-276-010044	Left center overwidth
3	3-276-010047	Short overwidth 47" long
	3-276-010055	Short overwidth 45 1/4" long
	3-276-010064	Short overwidth 32" long
	3-276-010065	Short overwidth 35 7/8" long
	3-276-010067	Short overwidth 39 1/4" long
4	3-276-010051	Extension support
5	3-276-010042	Overwidth extension 71" std.
	3-276-010056	Overwidth extension 59" long
6	3-557-010042	Support tube pin
7	#3	Hairpin
8	3-276-010053	Front extension support left
9	3-276-010054	Front extension support right
10	3/16 x 1 1/2 1/4	Cotter pin
11	3-557-010029	Hinge pin, overwidths
12	0600-250-01000	1/2 x 1 roll pin
13	3-869-010008	Support tube, combine wells
14	2-557-010010	Pin
15	3-174-010001	Chain, combine well support
16	516-22PTL	Pin
17	3-869-010007	Support bar, combine well chains
18	3-557-010055	Pin, support bar
19	E0650-063-1750	Spring
20	7/8	Flat washer
21	7/8-9 NC	Hex nut
22	3-276-010048 77	16" front extension
23	3-276-010049	Front extension support
24	3-557-010038	Pin, front ext. support, lower
25	3-557-010039	Pin, front ext. support, upper
26	3-276-010022	Overwidth extension
27	3-276-010052	Rear overwidth support slide
28	3-869-010004	Right combine well
29	3-869-010005	Left combine well

Note: Some early models and special models may have overwidth variations that are not listed above. If so, please specify length of overwidth and hinge spacing.

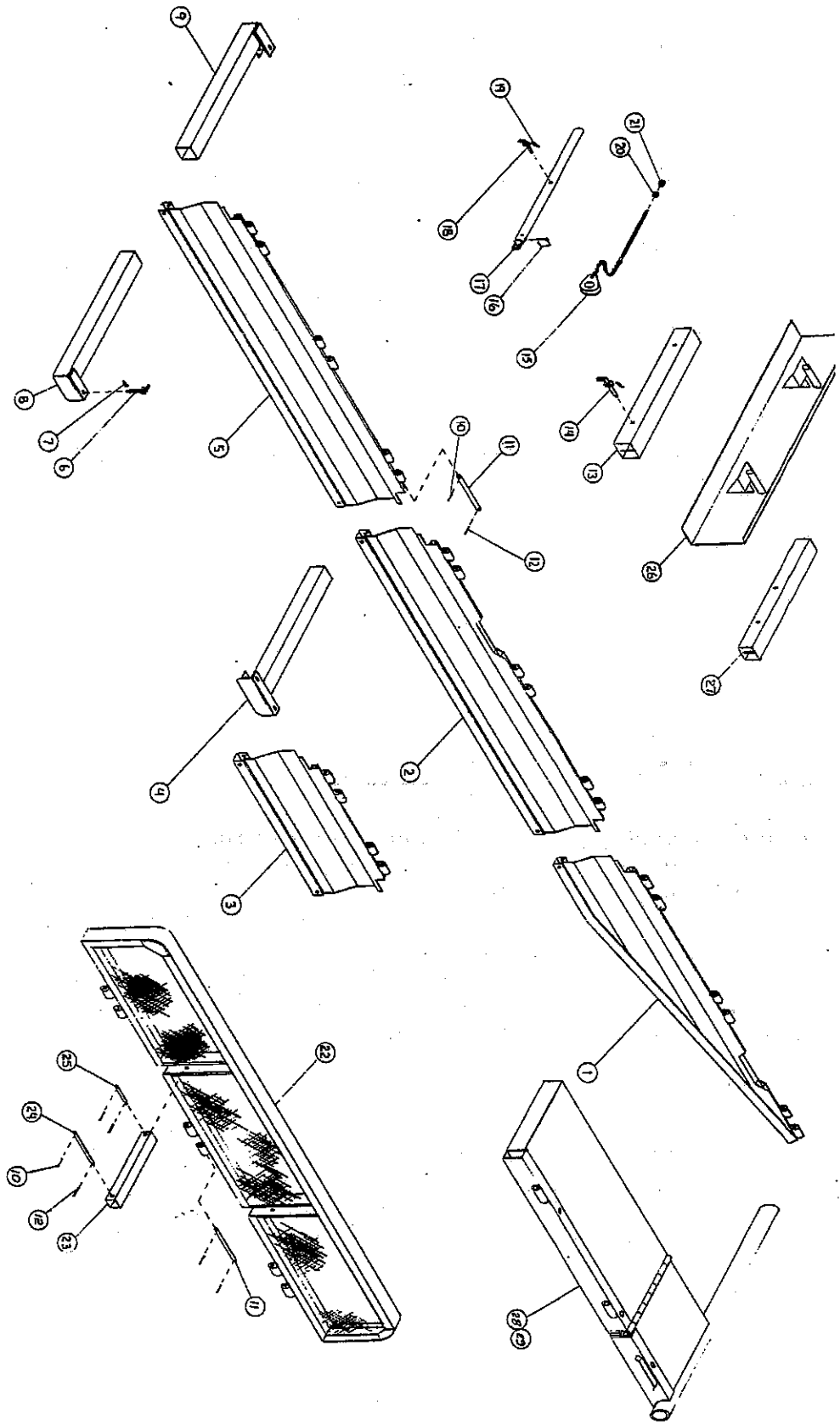

LHA5 FIFTH WHEEL
ELECTRICAL SYSTEM

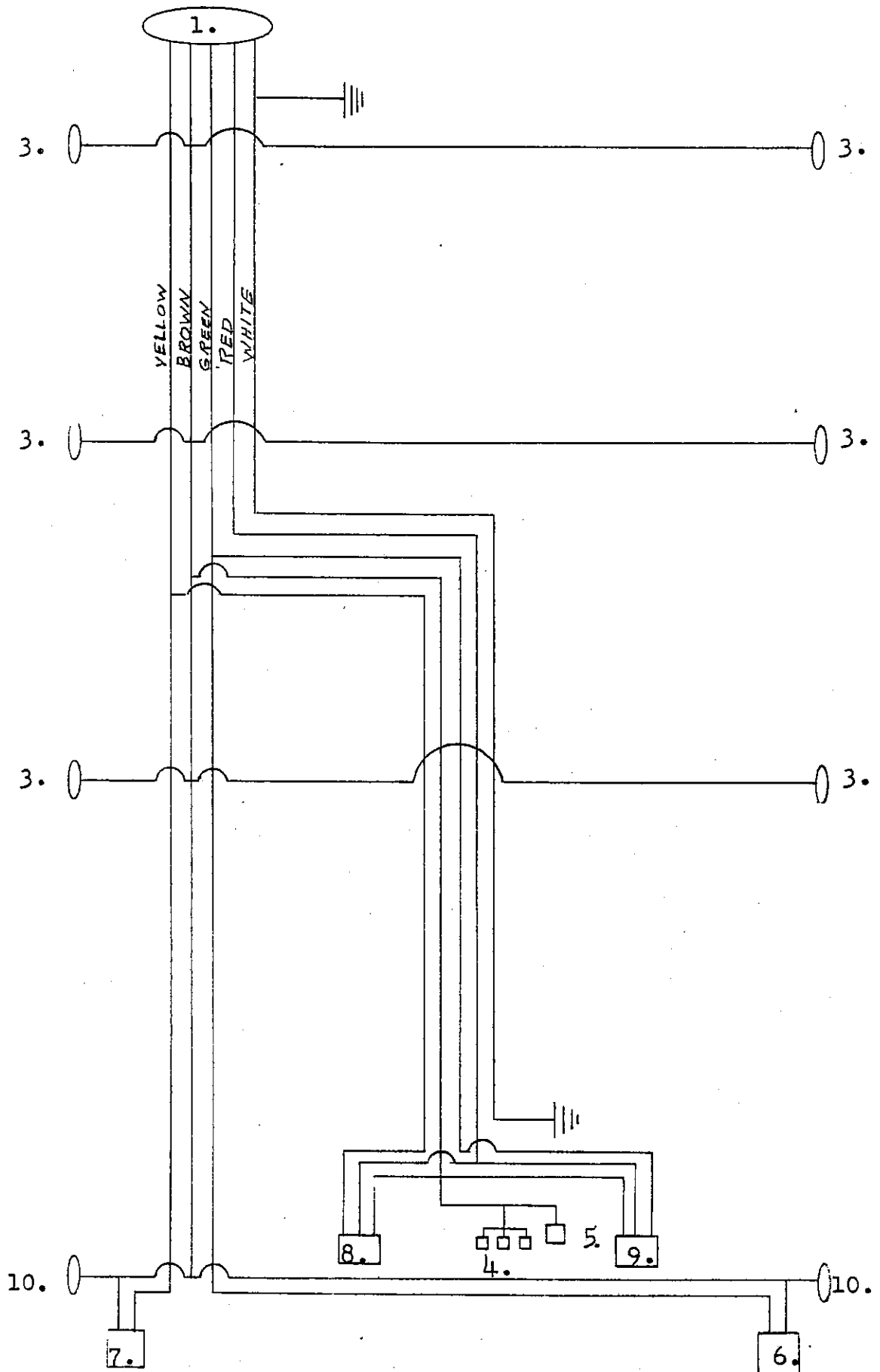

LHA5 FIFTH WHEEL

ELECTRICAL SYSTEM

1. 59S-7 trailer electrical socket, 7 pole
2. 3-368-010003 wiring harness
3. ~~PM~~-131A clearance light, amber
130-25-A lens, amber
194 bulb
4. ~~M~~107-^{R-12}31 identification light
107-15^R lens, red
1895 bulb
5. ~~M~~436-⁻¹²11 license light
436-01 hood
436-15 lens
194 bulb
6. 5237-²³20 tail light, right
9090²³ lens, long
9091²³ lens, short
1157 bulb
1895 bulb
7. 5236-²³20 tail light, left
9090²³ lens, long
9091²³ lens, short
1157 bulb
1895 bulb
8. 430L stop and tail light, left
430-15 lens
1157 bulb
9. 430R stop and tail light, right
430-15 lens
1157 bulb
10. ~~M~~131R clearance light, red
130-25-R lens, red
194 bulb

COMMON REPLACEMENT ITEMS

<u>ITEM</u>	<u>PART NO.</u>	<u>DESCRIPTION</u>
1	$\frac{1}{2}$ -6 x 25 3-102-010 014	Wire rope (Specify length) U-BOLT <i>(plus nuts)</i>
2	1426-562-02	3/8" high test chain
3	6470-431-00	3/8 clevis grab hook
4	3-793-010001	Tie down loop
5	2-557-010035	Lynch pin
6		$\frac{1}{2}$ " wire rope clamp
7	3-573-010009	Instruction decal, hyd. valves
8	1-573-010001	Decal, Landoll emblem, black $6\frac{1}{2}$ x $11\frac{1}{4}$
9	1-573-010013	Decal, Landoll emblem, white $6\frac{1}{2}$ x $11\frac{1}{4}$
10	1-573-010002	Decal, L, black
11	1-573-010014	Decal, L, white
12	1-573-010003	Decal, Landoll, black
13	1-573-010015	Decal, Landoll, white
14	1-573-010004	Decal, Hauloll, black
15	1-573-010016	Decal, Hauloll, white

<u>Item</u>	<u>Part No.</u>	<u>Description</u>
1	3-311-010145	Parking stand, right
2	3-311-010146	Parking stand, left
3	3-360-010004	Handle, jack lock
4	3/16 x 1 1/2	Cotter pin
5	E0 650-063-1750	Spring

