

# Heavy Duty Mechanic's Kit

20401

**TIGER  
TOOL**

Have What It Takes

## Safety Warning

**Read all instructions and safety warnings prior to operation. Failure to do so could result in equipment damage, personal injury or even death.**

**CAUTION 10102:** FAILURE TO CHECK THE SPHERICAL THRUST WASHER AND REPLACE AS NECESSARY MAY RESULT IN UNREPAIRABLE DAMAGE TO YOUR U-JOINT PULLER GLOVE CASTING. PREVENTATIVE MAINTENANCE AS OUTLINED ON NEXT PAGE WILL ENSURE MANY YEARS OF USE FROM YOUR TIGER TOOL PULLER. FAILURE TO PERFORM PREVENTATIVE MAINTENANCE WILL VOID YOUR WARRANTY.

**CAUTION 10409 & 10410:** THREADS MUST BE CLEAN AND WELL LUBRICATED AT ALL TIMES. DO NOT USE OVER ½" IMPACT WRENCH —DOING SO WILL VOID WARRANTY.

- **Stay Alert!** Watch what you are doing and use common sense when operating this tool.
- Inspect product for damage prior to using; do not use if product is in unsafe condition.
- Do not operate tool while under the influence of drugs, alcohol or medication.
- Always use safety equipment to prevent injuries. Approved face and eye protection must always be worn by the operator, as well as others in the work area.
- Do not overreach. Keep proper footing and balance at all times.
- Dress properly. Do not wear loose clothing or jewelry. Keep your hair, clothing and gloves away from moving parts.
- Keep your work area clean and well lit.



View demonstration videos and a complete product list at [tigertool.com](https://www.tigertool.com)

Technical Support  
1.800.661.4661

# Heavy Duty Mechanic's Kit

20401

**TIGER  
TOOL**

Have What It Takes

## Operating Instructions

### U-Joint Puller: 10102

**CAUTION:** Failure to check the spherical thrust washer and replace as necessary may result in unrepairable damage to your U-Joint Puller glove casting. Preventative maintenance as outlined above will ensure many years of use from your Tiger Tool puller. Failure to perform preventative maintenance will void your warranty.

- 1 Remove all fasteners from bearing cups.
- 2 Slip the U-Joint Puller over the yoke of the drive line.
- 3 Turn the tool's forcing screw clockwise with either an air or hand wrench. (Note: reverse thread)
- 4 Once bearing cup has been removed, repeat the process on the remaining bearing cups.

The 10102 U-Joint Puller may be used with up to a 1" impact wrench without voiding warranty.

### Preventative Maintenance

Keep forcing screw clean and lubricated at all times. Failure to maintain the spherical thrust washer located inside the glove will result in excessive wear to the part. Check and lubricate this part (lubricate load bearing surface in glove, under cap, on both sides of spherical washer) periodically and replace as necessary. Contact your Dealer or Tiger Tool for replacement washers. (We recommend SAE 30 lube for the threads and EP 'with molly grease').

### Bearing Cup Installer: 10201

- 1 Ensure all parts to be assembled are clean and/or greased where applicable.
- 2 Double check all needle bearings are present and placed correctly.
- 3 Start pressing bearing cup into yoke by hand, making sure the U-Joint cross and bearing cup bolt holes line up.
- 4 Place installer onto bearing cup, threading bolts into the yoke.
- 5 Using an impact or hand wrench, turn forcing screw until cup is flush to yoke.
- 6 Remove tool and install bearing cup bolts.

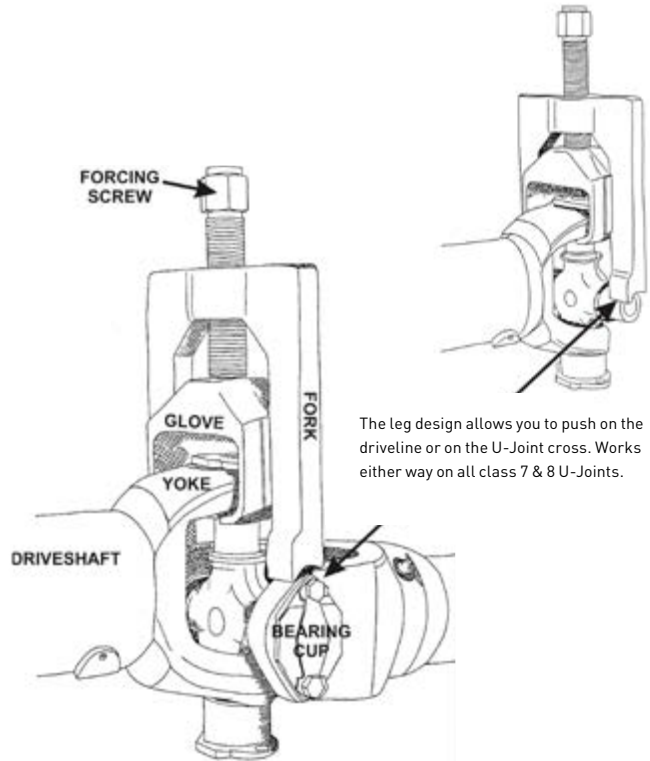

The leg design allows you to push on the driveline or on the U-Joint cross. Works either way on all class 7 & 8 U-Joints.



View demonstration videos and a complete product list at [tigertool.com](http://tigertool.com)

Technical Support  
1.800.661.4661

# Heavy Duty Mechanic's Kit

20401

**TIGER  
TOOL**

Have What It Takes

## Tie Rod End Remover: 10301

- 1 Remove any original nuts and/or cotter pins from parts to be separated.
- 2 Select correct tool according to thread size of tie rod.
- 3 Spin the tool completely onto the threaded arm.
- 4 Back tool off one complete turn.
- 5 Strike the remover with a hammer; tie rod will become loose.
- 6 Remove tool and part to be removed will drop off.



## Gunite/Brunner/Bendix Slack Adjuster Puller: 10409

CAUTION: Threads must be clean and well lubricated at all times. Do not use over ½" impact wrench—doing so will void warranty.

- 1 Remove clevis from the end of the slack adjuster with the Tiger Tool 10501 Brake Clevis Pin Press.
- 2 With the forcing screw backed fully out, slip the puller onto the slack adjuster.
- 3 Attach tool to slack adjuster through clevis hole and tighten.
- 4 Turn the forcing screw by hand or with an impact wrench.
- 5 Slack adjuster will drop off when free.



View demonstration videos and a complete product list at [tigertool.com](https://www.tigertool.com)

Technical Support  
1.800.661.4661

# Heavy Duty Mechanic's Kit

20401

**TIGER  
TOOL**

Have What It Takes

## Haldex Multi Adjustable Slack Adjuster Puller: 10410

CAUTION: Threads must be clean and well lubricated at all times. Do not use over ½" impact wrench—doing so will void warranty.

- 1 Remove clevis pin and clevis from the end of the slack adjuster with the Tiger 10501 Brake Clevis Pin Press.
- 2 Select proper arm and attach to puller main body with ½" x 1" bolt supplied. Do not tighten at this time. Note the straight arm is for older style Haldex slacks while the bent arm is for newer angled and/or offset Haldex slack adjusters.
- 3 With forcing screw fully backed out, slip the puller onto the slack adjuster.
- 4 Insert ½" x 2 ½" bolt through clevis pin hole and puller arm slot. Secure with washer and nut by hand.
- 5 Tighten ½" x 1" and ½" x 2 ½" to securely mount puller to slack adjuster.
- 6 Turn the forcing screw with hand or ½" impact wrench.
- 7 Slack adjuster will drop off when free.



Here at Tiger Tool, your satisfaction is our number one priority. Should you have any questions about this or any of our products, please call us at 1.800.661.4661.



View demonstration videos and a complete product list at [tigertool.com](https://www.tigertool.com)

Technical Support  
1.800.661.4661

# Heavy Duty U-Joint Puller

10102

**TIGER  
TOOL**

Have What It Takes

## Parts Breakdown

### Part #10101

10102 Maintenance Pack  
Contains each of the following items:



Also available separately.

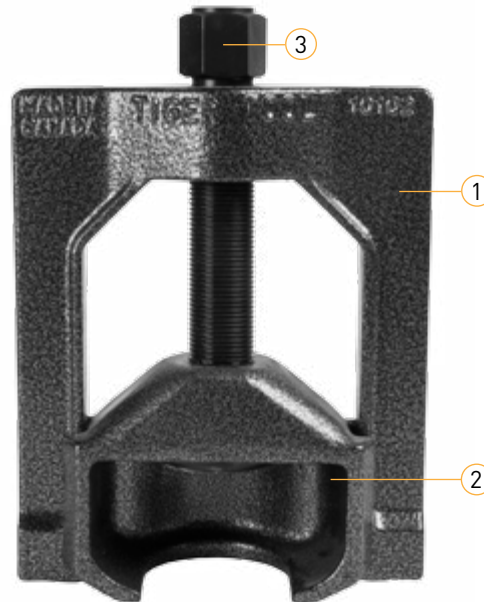

Item No.	Part Number	Description	Qty.
1	10102-1	Fork	1
2	10102-2	Glove	1
3	10102-3	Forcing Screw	1
4	10102-4	Retaining Bolt	1
5	10102-5	Washer	1
6	10102-6	Dome Plug	1



View demonstration videos and a complete product list at [tigertool.com](http://tigertool.com)

Technical Support  
1.800.661.4661

# Bearing Cup Installer

10201

**TIGER  
TOOL**

Have What It Takes

## Parts Breakdown

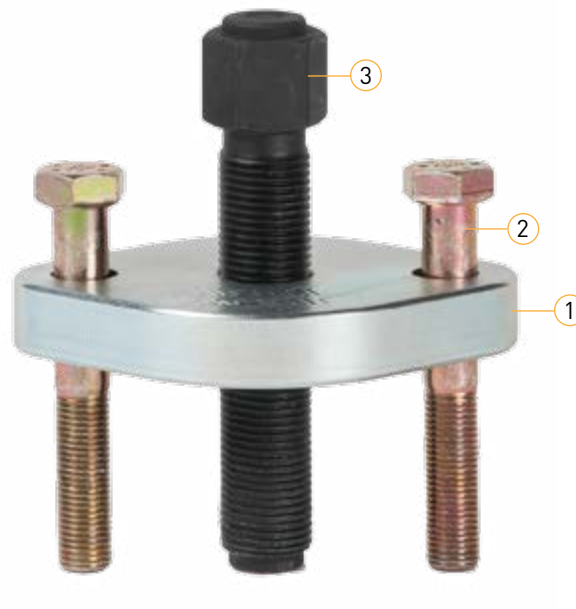

Item No.	Part Number	Description	Qty.
1	10201-1	Plate	1
2	10201-2	Bolt	2
3	10201-3	Forcing Screw	1



View demonstration videos and a complete product list at [tigertool.com](http://tigertool.com)

Technical Support  
1.800.661.4661

# Gunite/Brunner/Bendix Automatic Slack Adjuster Puller

10409



Have What It Takes

## Parts Breakdown



Item No.	Part Number	Description	Qty.
1	10409-1	Body	1
2	10407-2	Forcing Screw	1
3	10409-2	Bolt	1
4	10407-4	Washer	2
5	10407-5	Nut	1



View demonstration videos and a complete product list at [tigertool.com](http://tigertool.com)

Technical Support  
1.800.661.4661

# Haldex Multi Adjustable Automatic Slack Adjuster Puller

10410

**TIGER  
TOOL**

Have What It Takes

## Parts Breakdown

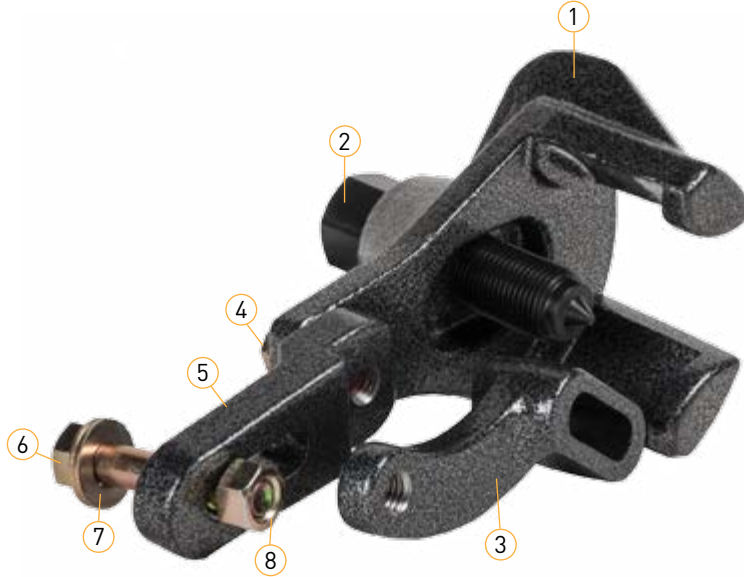

Item No.	Part Number	Description	Qty.
1	10410-1	Body	1
2	10407-2	Forcing Screw	1
3	10410-3	Bent Arm	1
4	10410-4	Bolt	1
5	10410-2	Straight Arm	1
6	10409-2	Bolt	1
7	10407-4	Washer	1
8	10407-5	Nut	1



View demonstration videos and a complete product list at [tigertool.com](http://tigertool.com)

Technical Support  
1.800.661.4661