

REVISION HISTORY		
REV.	DESCRIPTION	DATE
01	PRELIMINARY RELEASE PER EL0077	2016-11-28
A	INITIAL RELEASE PER EL0077	2017-01-19
B	REVISE PER EL0077	2017-02-14

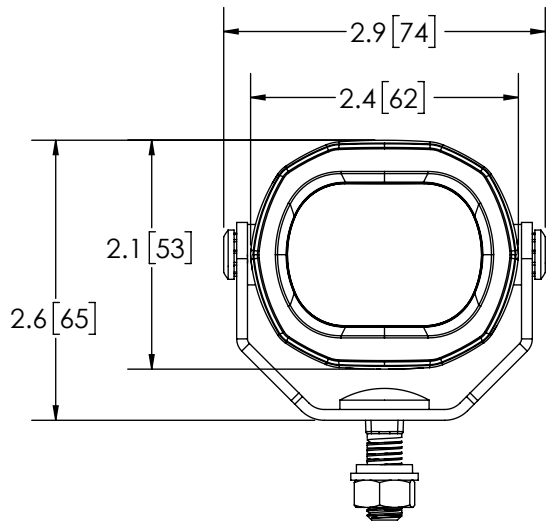
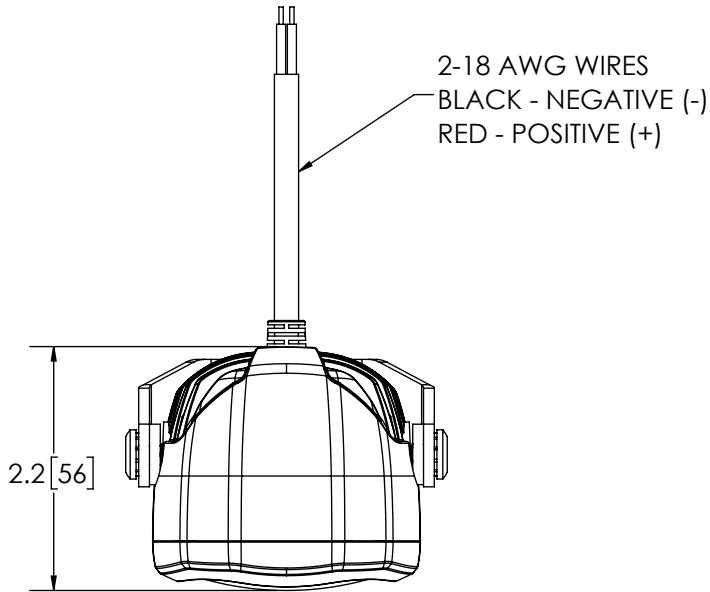

SPECIFICATIONS

- CERTIFICATIONS: ECE R10; C-Tick ;
Note: Unique components, accessories, and hardware kits are not typically Included in the Product Certification Test Protocols. Unless otherwise Specified, the Product Certifications referred to herein are predicated upon the base product model configuration.
- RAW LUMENS: 86 lumens
- EFFECTIVE LUMENS: 65 lumens
- ILLUMINANCE: 1.6 lux
- PEAK BEAM INTENSITY: 1433 Candela
- EFFICACY: 16.5 lm/W
- CORRELATED COLOR TEMPERATURE: 1000K
- VOLTAGE (NOMINAL): 12 to 80 VDC
- VOLTAGE (EXTREME): 9.0 to 86.0 VDC
- CURRENT (PEAK): 1.03A (@ 12 VDC NOMINAL)
- POWER (MAXIMUM): 13.2W (@ 12 VDC NOMINAL)
- TEMPERATURE RANGE: -22°F (-30°C) TO 122°F (50°C)
- CONNECTION: 2 - 18 AWG WIRE CABLE
- MOUNTING: BRACKET MOUNT
- HOUSING MATERIAL: ALUMINUM
- LENS MATERIAL: POLYCARBONATE
- PRODUCT WEIGHT: 0.6 LBS (0.27 Kg)

DISCLAIMER

DIMENSIONS, ILLUSTRATIONS, SPECIFICATIONS AND CERTIFICATIONS CONTAINED IN THIS DOCUMENT ARE TYPICAL OF THE ACTUAL PRODUCT AND ARE SUBJECT TO CHANGE. ECCO ENGINEERING DOES NOT MAINTAIN FORMAL DESIGN CONTROL OF THIS PRODUCT.

MOUNTING DISCLAIMER

MOUNTING MEASUREMENT IS FOR REFERENCE ONLY.
MEASURE BEFORE DRILLING.

NOTES:

- ROHS COMPLIANT
- DIMENSIONS IN INCHES[MILLIMETERS (FOR REFERENCE)]

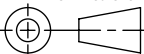
SCALE 1:1.75		APPROVALS	DATE	 www.eccolink.com Americas (800) 635-5900 Europe +44 (0)113 237 5340 Asia Pacific +61 (0)3 63322444
CAD GENERATED DRAWING DO NOT MANUALLY UPDATE. MODEL REFERENCED:A		DRAWN BY	2017-02-03	
TOLERANCES ARE IN INCHES, AND MILLIMETERS TOLERANCES UNLESS OTHERWISE STATED ARE:		CHECKED MDH	2017-02-06	
MILLIMETERS DECIMALS XX. ± 1.0mm XX.X ± 0.5mm	INCHES DECIMALS X.X ± 0.1 X.XX ± 0.04 X.XXX ± 0.02	MECH. ENG. KLR	2017-02-03	
		ELEC. ENG. JES	2017-02-08	
		TEST ENG. JRT	2017-02-07	
		SALES. LAT	2017-02-06	
		CUSTOMER PART NO. EW2015R		
		PRODUCT SERIES: EW2015		
NON DISCLOSURE AGREEMENT		SIZE: A	DWG. NO. EW2015R	REV. B
<small>THIS DRAWING AND THE DESIGN IT DISCLOSES ARE THE PRIVATE PROPERTY OF ESG AND IS ISSUED IN CONFIDENCE FOR ENGINEERING INFORMATION ONLY. THE DRAWING AND / OR DESIGN MAY NOT BE USED, COPIED, REPRODUCED, OR OTHERWISE DISCLOSED IN PART OR AS A WHOLE TO OUTSIDERS OR USED FOR ANY OTHER PURPOSE WITHOUT THE PRIOR WRITTEN CONSENT OF ESG. THE DRAWING IS SUBJECT TO RECALL AT ANY TIME. YOUR POSSESSION OF THIS DOCUMENT CONSTITUTES ACCEPTANCE OF THESE TERMS. © 2016 ECCO</small>				Electronically Controlled Use Latest Copy SHEET 1 OF 1 Project: EL0077 Date Created: 2016-11-28