



HANDLELOK P/N 1004

INSTALLATION INSTRUCTIONS



For additional assistance call 888-514-0083 between 8AM-5PM EST or email: info@pactoolmounts.com

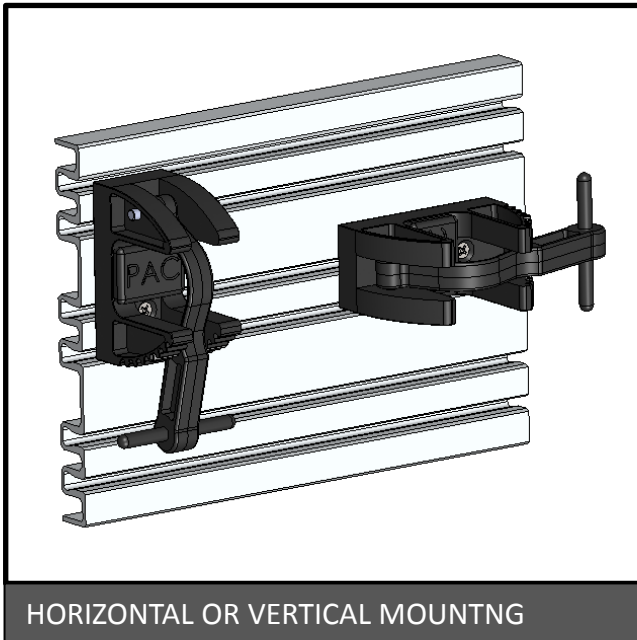

CAUTION

To avoid the risk of personal injury, property damage or product damage, please use the included fasteners for mounting.

- * The bracket must be securely mounted to a stable surface and material.
- * When mounting bracket to PAC TRAC aluminum products **P/N 7000, P/N 7020, P/N 7040, P/N 7050** with the included Trac Lok inserts **P/N 7016**, torque the screws to a maximum 15 in-lbs.
- * PAC recommends regular and frequent inspections to be certain of proper operation and installation.



STANDARD MTG. HARDWARE		QTY
	P/N 3017 ¼-20 x 1 S.S. S.S. Pan Head Screw	2
	P/N 2069LN ¼-20 S.S. Locking Hex Nut	2

PAC TRAC MTG. HARDWARE		QTY
	P/N 2046 #10-24 x 1 S.S. S.S. Pan Head Screw	2
	P/N 7016 TRAC LOK INSERT	2

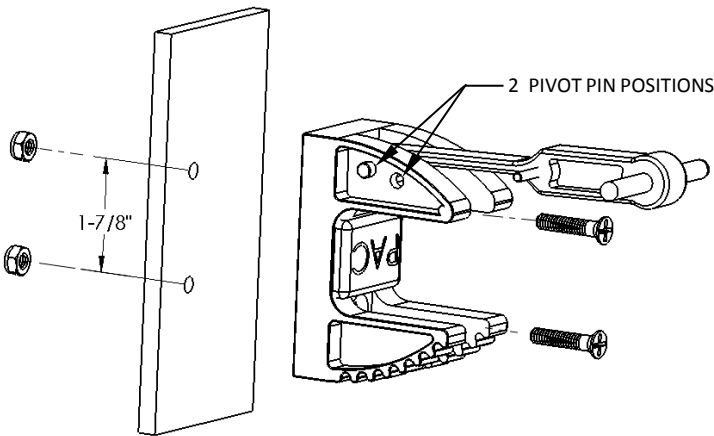

FIGURE 1
(Thru Mounting Method)

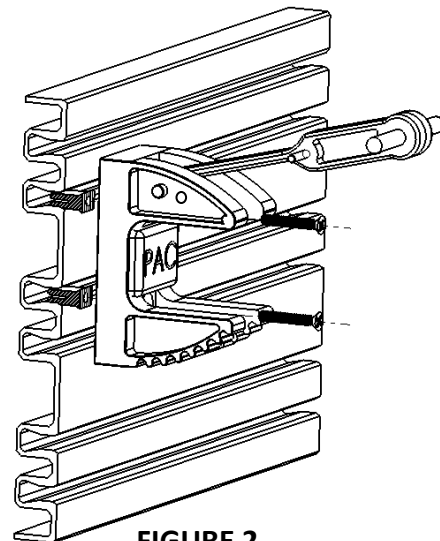

FIGURE 2
(PAC TRAC Mounting)



HANDLELOK STRAP PIVOT REPOSITION

INSTRUCTIONS

For additional assistance call 888-514-0083 between 8AM-5PM EST or email: info@pactoolmounts.com

The elastomer lock strap can be repositioned to a higher pivot position to allow the securing of objects which are oversized.



Please read, understand and follow these instructions. Failure to properly assemble may result in personal injury and/or property damage.

Contact PAC customer service for product warranty information.

STEP 1 – Remove Strap

Remove the pivot pin to free the strap. You may drive it through the bracket by tapping it with a punch pin or by grasping the exposed end with a pliers and pulling it through. See figures 2A & 2B

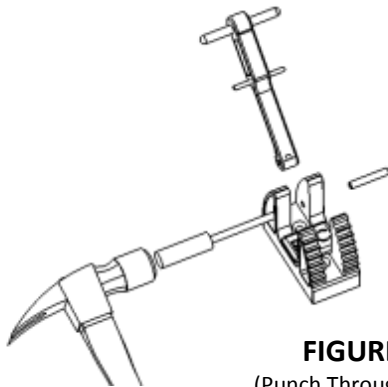

FIGURE 2A
(Punch Through Method)

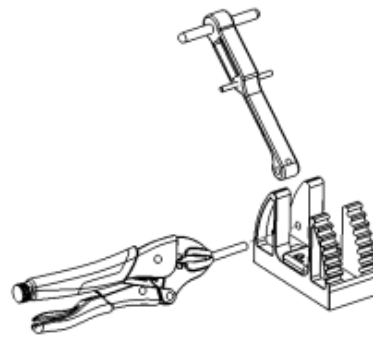

FIGURE 2B
(Grip Method)

STEP 2 – Replace Strap and Insert Pivot Pin

Place the strap in line with the pivot pin hole and carefully insert the pin through the bracket and strap. Allow approximately $\frac{1}{4}$ " of pin to extend on each side. The correct orientation of the strap is where the circular mark is visible on the underside of strap after assembly. See figures 2C & 2D
Verify that the pin is secure after insertion.

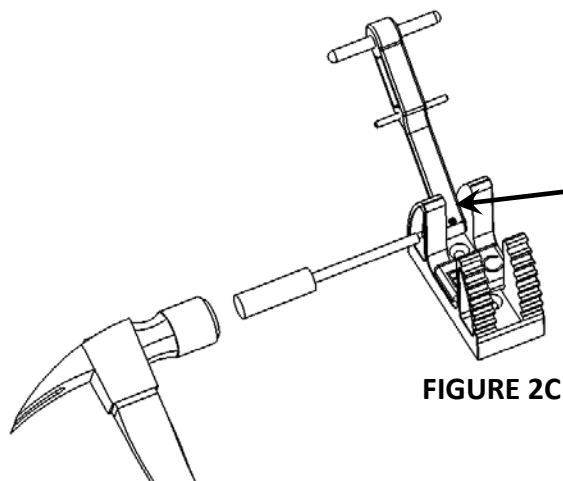

FIGURE 2C

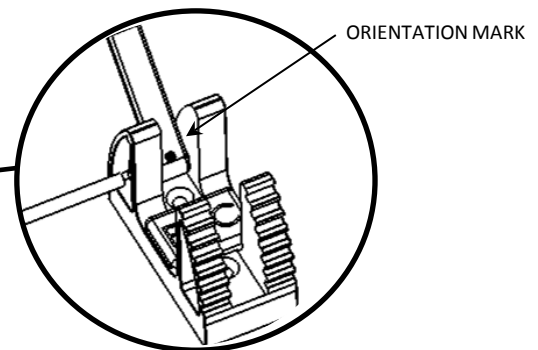

FIGURE 2D

ORIENTATION MARK