



# PRODUCT DATA SHEET

## P/N: 1110 MINI HOOK



### FEATURES

\*SOLD IN PAIRS\*

- Rugged injection molded components made from high quality materials
- Weather, UV resistant
- Non-conductive
- Can be mounted horizontally or vertically
- Stainless Steel Fasteners provided
- Mounts to PAC tool boards, PAC Strut and other flat surfaces.

### TYPICAL SPECIFICATION

Mounting Bracket shall be PAC PN 1110.

Bracket shall be single piece construction; made from tough, corrosion free material. Hardware shall be stainless steel.

Firefighters shall be protected from conductivity.

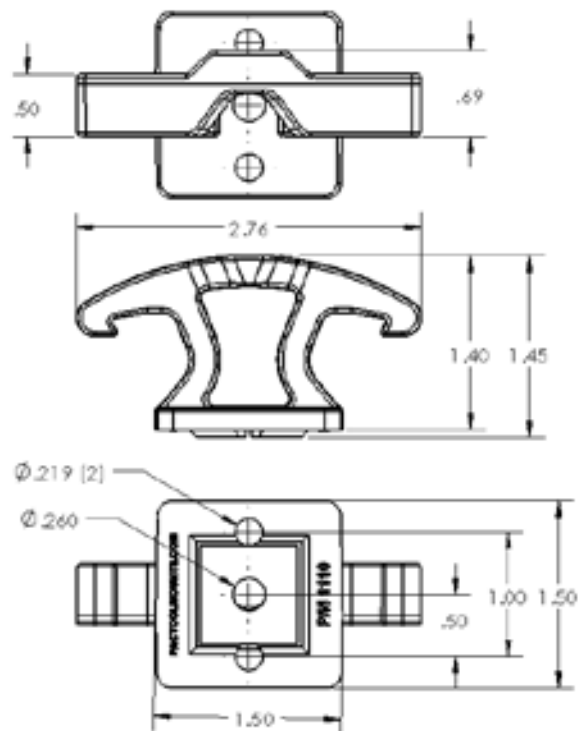

Dimensions: 1.45" x 1.5" x 2.76"

### SPECIFICATIONS

P/N	WT.	MAX LOAD	GRIP RANGE	HANGER MAX LOAD	FLAME TOXICITY CHEMICAL
1110	.7 OZ EA.	N/A	N/A	TBD	N/A

Performance Advantage Company Lancaster, New York

[www.pactoolmounts.com](http://www.pactoolmounts.com)

888-514-0083

REFERENCE	QTY	REMARKS	PROJECT
			LOCATION
			BUYER
			DEALER
			BUILDER
			SUBMITTED BY:
			DATE:



**SOLD IN PAIRS – The MINI HOOK BRACKET is a versatile and easy to use hanger/clip product providing attachment points for lightweight tie downs and hanger applications.**

- Perfect for bags, bungees, clip on tools and equipment.
- Works great with PAC Strut
- Rugged injection molded components made from high quality materials
- Weather, UV resistant
- Non-conductive
- Can be mounted horizontally or vertically

