

| REV | DESCRIPTION | DATE | APPR |
|-----|-------------|------|------|
|     |             |      |      |

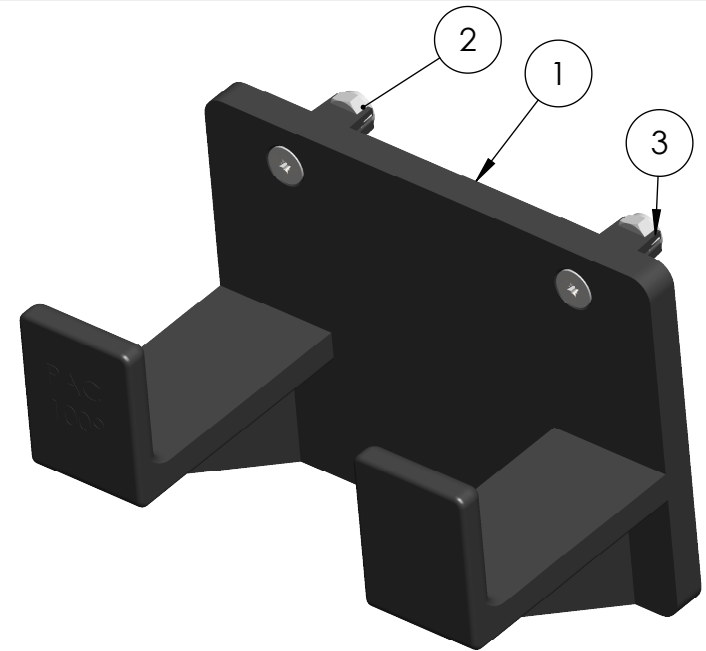
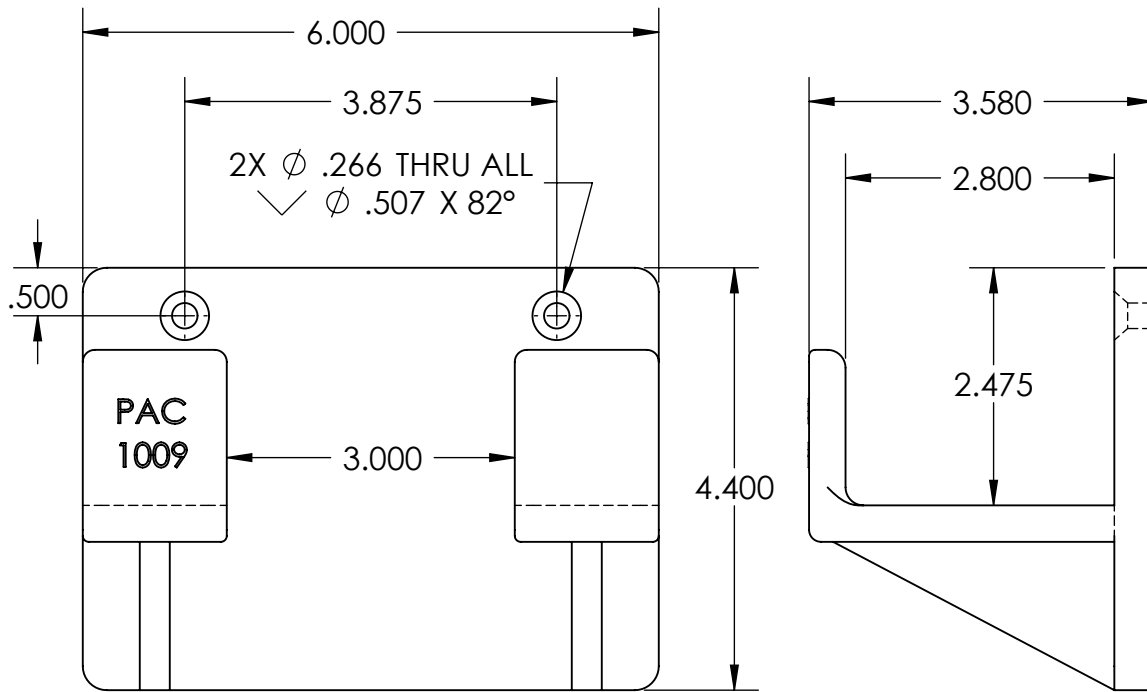

| 3        | 7021    | FASTENER KIT        | 1   |
|----------|---------|---------------------|-----|
| 2        | 2032    | FASTENER KIT        | 1   |
| 1        | 1009P   | TOOL HANGER BRACKET | 1   |
| ITEM NO. | PAC P/N | PART NAME           | QTY |

**NOTES:**

**P**ERFORMANCE  
**A**DVANTAGE  
**C**OMPANY



**TOLERANCES UNLESS OTHERWISE SPECIFIED**

.X= ± .03  
.XX= ± .010  
.XXX= ± .005  
.XXXX= ± 0.0005  
ANGLES ± 0.5 °  
FRACTIONAL ± 1/64

THIRD ANGLE PROJECTION



COLOR

NAME DATE

DRAWN BY

APPR. BY

MFG BY

MFG. P/N

ENG APPR.

MATERIAL

ALT. MATERIAL

FINISH

THE INFORMATION CONTAINED IN THIS DRAWING IS THE SOLE PROPERTY OF **PERFORMANCE ADVANTAGE CO.** ANY REPRODUCTION IN PART OR AS A WHOLE WITHOUT THE WRITTEN PERMISSION OF PERFORMANCE ADVANTAGE CO. IS PROHIBITED.

**TITLE:**

**TOOL HANGER BRACKET**

**PART NUMBER**

**1009**

REV

**SCALE: 1:2**

**SHEET 1 OF 2**