

711265	Bracket Assy. (Inc. item 1)		Kit No.	700358
711267	Bracket Bolt Pkg. (Inc. items 8, 9, 14, 22)		Make	Ford pickup
711183	Pulley Bolt Pkg. (Inc. 17-19)		Engine	5.4, 6.8L
711268	Idler Bolt Pkg. (Inc. items 11, 12, 15, 20)		Fuel	Gas
None	Fan Spacer Bolt Pkg.		Year	1999
			Equipment	With A/C
			Revised	G 3-24-10

ITEM	PART #	DESCRIPTION			
1.	711265	Pump mount bracket	13.	110425	3/8-16 x 1 1/4 Bolt
2.	740296	Tensioner	14.	110676	3/8 Flat washer
3.	-----	-----	15.	711072	Bushing
4.	740233	Serpentine idler	16.	740257	Crankshaft pulley
5.	110252	Washer	17.	110180	M10 x 1.5 x 60 Bolt
6.	*	Pump	18.	110689	M10 Lock washer
7.	742016	Clutch	19.	110676	3/8 Flat washer
8.	110183	M10 x 1.5 x 100 Bolt	20.	-----	-----
9.	110422	5/16-18 x 3/4 Bolt	21.	711314	Air cleaner bracket
10.	-----	-----	22.	710587	3/16 x 3/4 Self-tapping screw
11.	110479	M10 x 1.5 x 30 bolt	23.	740262	Belt/Micro-V K060703
12.	110255	1/2-13 x 3 Bolt			

\* Part number to be determined at time of order.

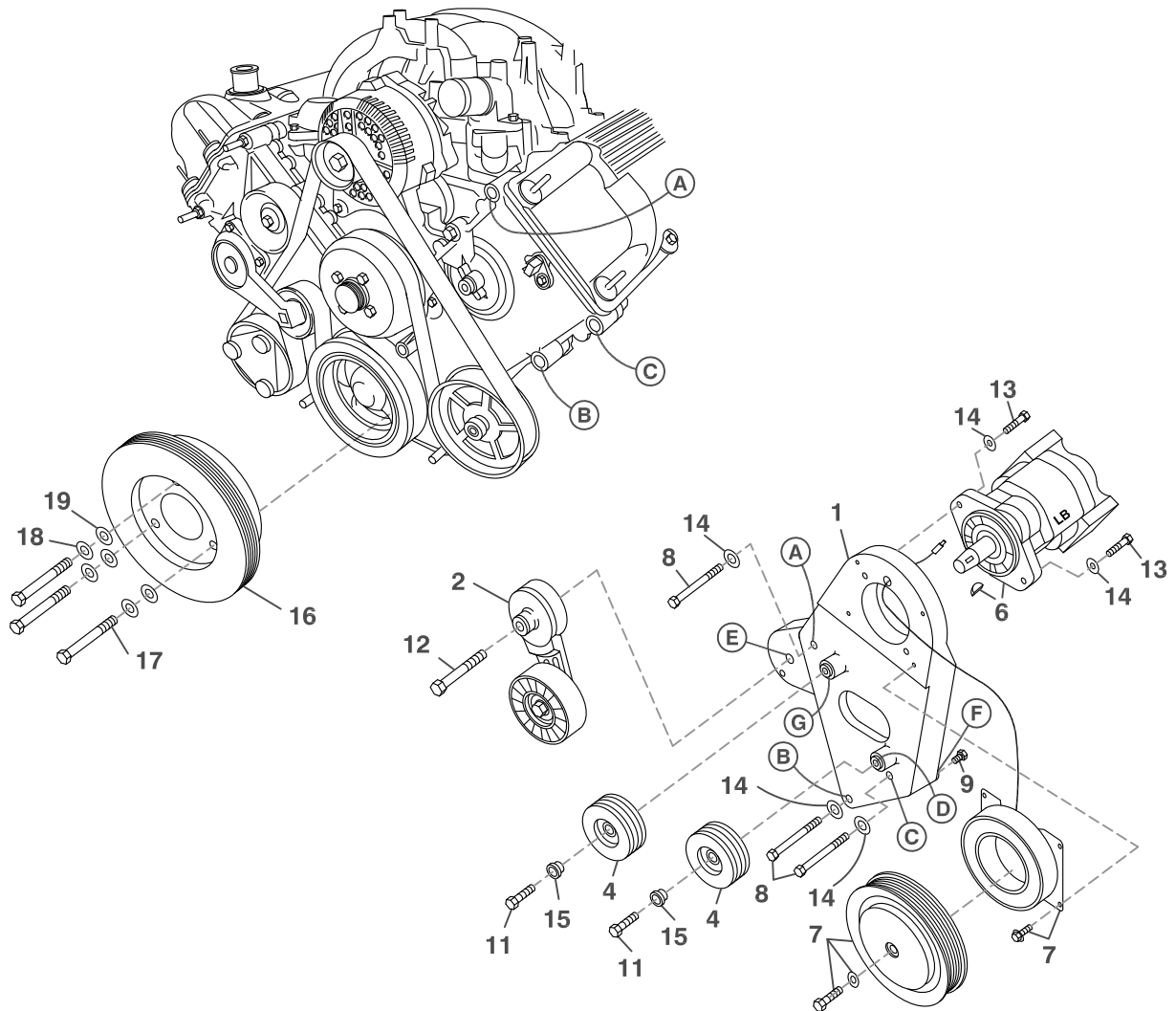

(A) (B) (C)... Denotes bolt holes in engine to locate corresponding holes in Pump Brkt.

FIG. 2  
BELT DIAGRAM

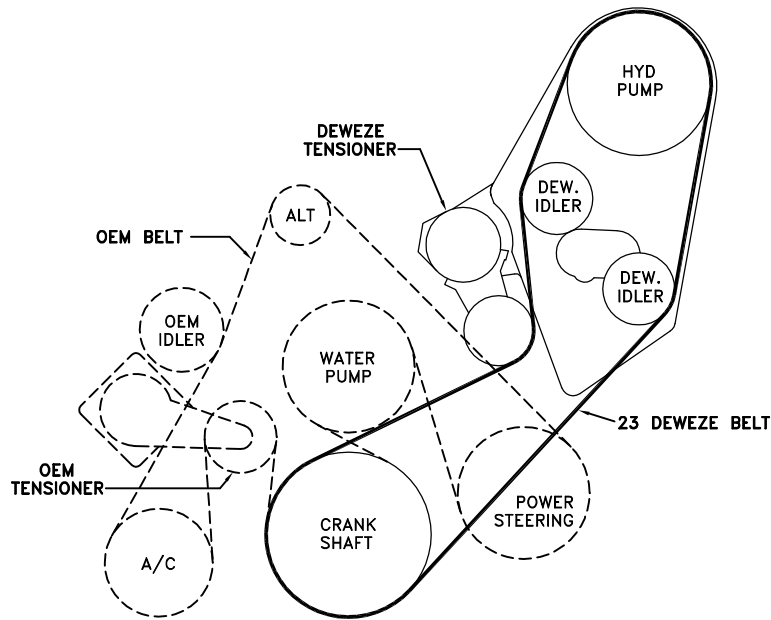
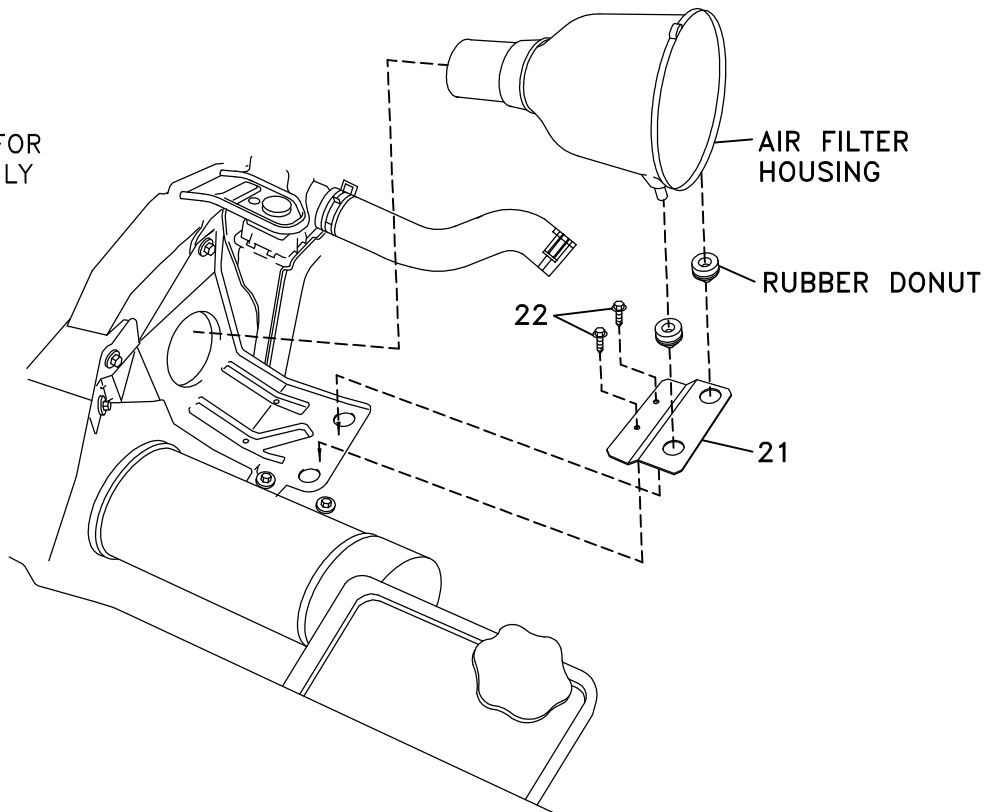

FIG. 3  
AIR CLEANER  
REPOSITIONING FOR  
5.4L ENGINE ONLY



# DewEze

## CLUTCH PUMP KIT

700358  
Ford  
5.4L, 6.8L  
w/ and w/o A/C  
'A' mount  
1999+

### INSTALLATION INSTRUCTIONS

1. Drain the radiator.
2. Remove the upper radiator hose. Make note as to which end is which, as it will be turned around when it is installed later.
3. Remove the fan shroud and fan.

NOTE: Instructions 4, 5, and 16, repositioning the air cleaner, are for the 5.4L engine only. Refer to Fig. 3. If you have the 6.8L engine, discard the DewEze air cleaner bracket (21).

4. Remove the air filter housing by releasing the large toggle clamp and pulling the front filter housing up and to the rear. Tie the rear of the housing and inlet tube to the rear of the engine compartment to keep it out of the way.
5. Remove the rubber donuts from the OEM air cleaner support and place them in the holes in the DewEze air cleaner bracket (21). Hold this bracket on top of the OEM support placing the small holes in the DewEze bracket in between the large holes in the OEM support. Run the 3/16 x 3/4 self-tapping screws (22) through the small holes into the OEM support.
6. Remove OEM bolts from engine at locations A, B, and C. Lay the wiring off to the side.
7. Mount the crank pulley (16) to the damper using three M10 x 60 bolts (17), 10mm lock washers (18), and 3/8 flat washers (19).
8. Bolt the pump (6) to the rear of the mounting bracket (1) using two 3/8 x 1 1/4 bolts (13) and two 3/8 flat washers (14). Attach the clutch coil (7) to the front of the bracket using four flange bolts supplied with the clutch. Insert the coil wire through the 1/2" hole right above the coil to keep it from contacting the clutch pulley.
9. Mount the tensioner on the pump bracket at location E with the 1/2 x 3 1/2 bolt (12), inserting the bolt head on the back of the tensioner into the small hole on the tensioner mounting pad.
10. Insert an M10 x 30 bolt (11) through an idler bushing (15) and into a serpentine idler pulley (4). Do this to the other serpentine idler also. Mount one idler onto the boss at location D and the other idler on the boss at location G.
11. Mount the pump bracket onto the engine at locations A, B, and C with the three M10 x 100 bolts (8) with 3/8 flat washers (14). Torque these bolts to 30-41 ft/lbs.
12. Bolt the wiring harness holder to the back of the pump bracket at location F using a 5/16 x 3/4 bolt (9).
13. Mount the clutch pulley (7) onto the pump shaft using the bolt and washer supplied with the clutch.
14. Install the pump drive belt (23) making sure pulleys are aligned and the belt is straight.
15. Replace the upper radiator hose, turning the ends opposite from the way it was originally. This is to give enough clearance between the clutch and the hose.

16. Replace the air filter housing and filter into the hole in the front of the truck then push it down into the rubber donuts in the new location. Untie the rear housing and clamp it to the front half.
17. Replace the coolant in the radiator.
18. Reconnect the battery.
19. Run the engine and check for alignment and clearance problems. Adjust if needed.