

**Ford, 5.4L, 6.8L:G, 2008+, A Pump, PH14, Side Port**

**Bolt Packages:**

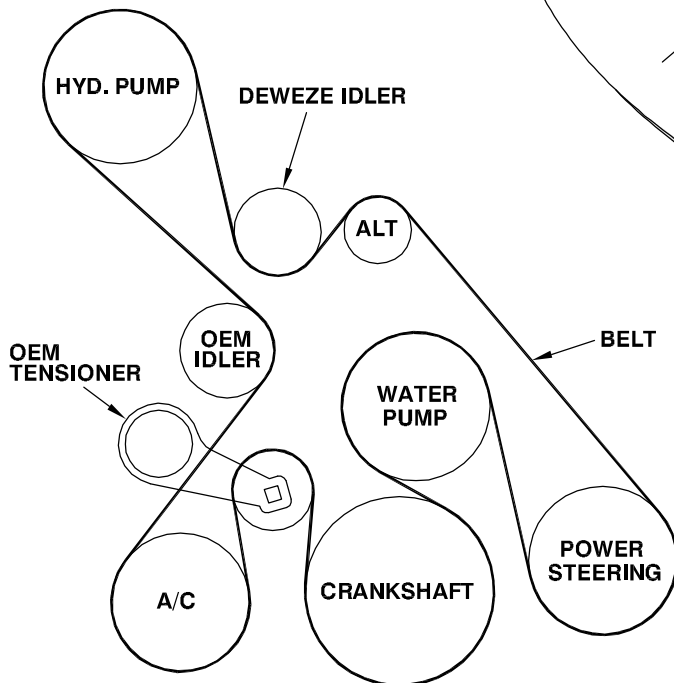
|              |                            |
|--------------|----------------------------|
| Bracket      | 716059 (Inc. 7, 11, 24-27) |
| Idler pulley | 711891 (Inc. 8, 10)        |
| Pulley       | None                       |
| Tensioner    | None                       |

|            |          |               |   |         |
|------------|----------|---------------|---|---------|
| Issue Date | 10-26-11 | Revision Date | A | 3-22-12 |
|------------|----------|---------------|---|---------|

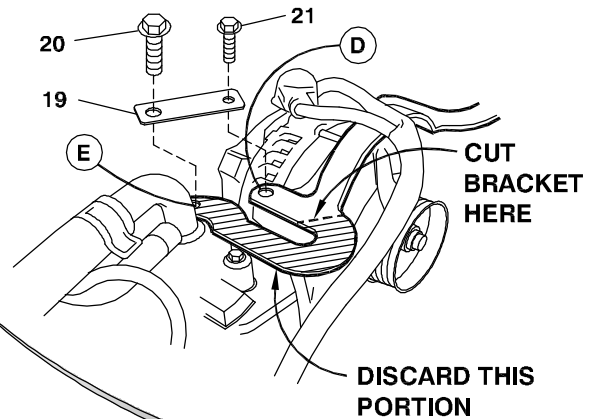
**Item Part No. Description**

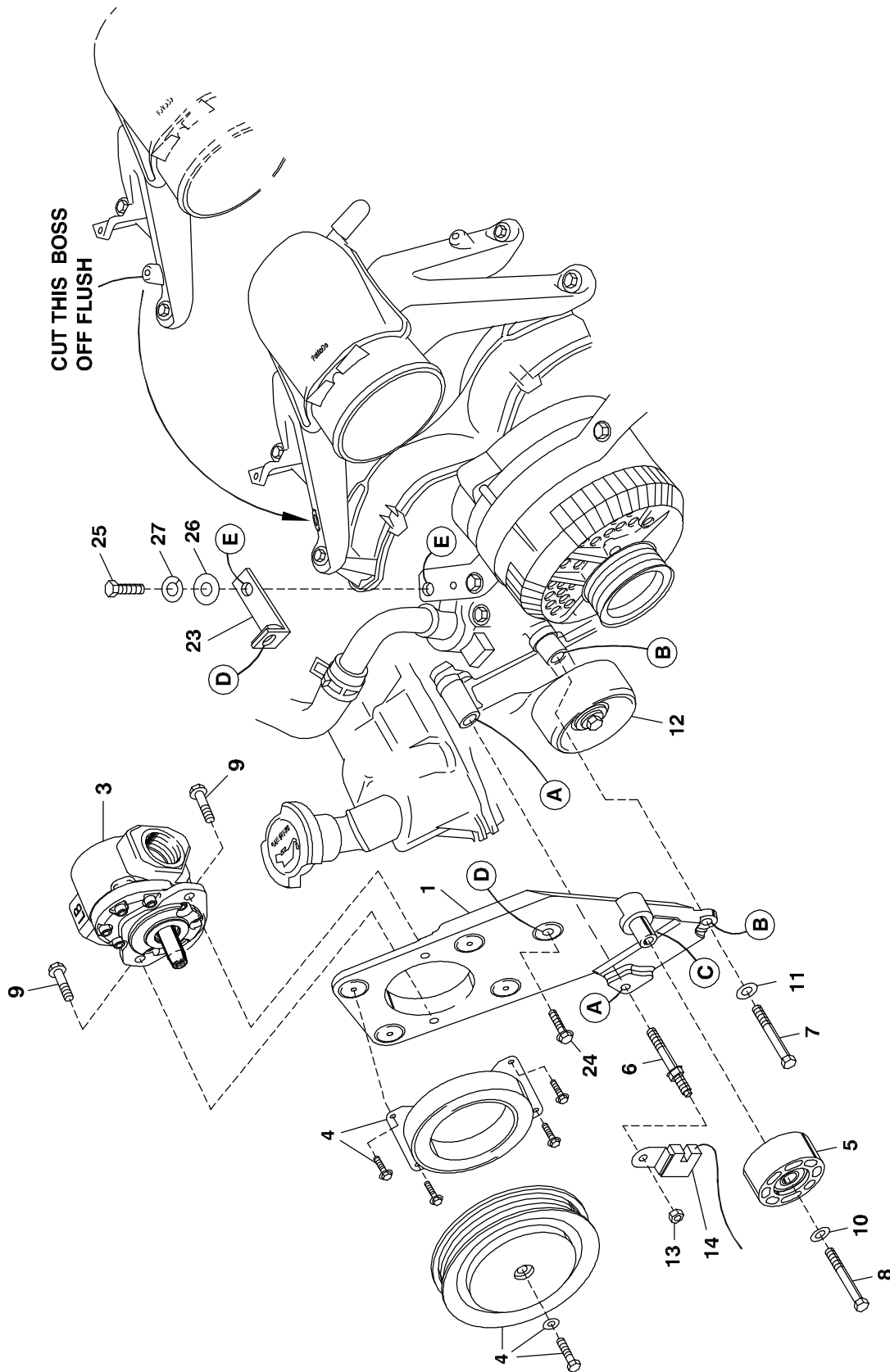
|     |        |                     |     |        |                                 |
|-----|--------|---------------------|-----|--------|---------------------------------|
| 1.  | 711893 | Pump bracket        | 15. | 742057 | Belt, Dayco 1298K6              |
| 2.  | -----  | -----               | 16. | OEM    | Air tube                        |
| 3.  | *      | Pump                | 17. | 102058 | Plug, recessed button 1 3/4"    |
| 4.  | 742016 | Clutch              | 18. | 110915 | Plug, tapered silicone, 1 7/16" |
| 5.  | 740151 | Idler pulley        | 19. | 711944 | Plate, alternator bridge        |
| 6.  | OEM    | Stud bolt           | 20. | OEM    | Bolt                            |
| 7.  | 110291 | M8 x 1.25 x 60 Bolt | 21. | OEM    | Bolt                            |
| 8.  | 110210 | M10 x 1.5 x 50 Bolt | 22. | 702101 | Plug, recessed button 1 5/16"   |
| 9.  | 110440 | 3/8 x 1 Flange Bolt | 23. | 715027 | Support, pump bracket           |
| 10. | 110676 | 3/8 Flat washer     | 24. | 110161 | 3/8-16 x 1.25 Flange head bolt  |
| 11. | 110703 | M8 Flat washer      | 25. | 110932 | M6 x 1.0 x 30 Bolt              |
| 12. | OEM    | Idler pulley        | 26. | 110673 | 1/4 Flat washer                 |
| 13. | OEM    | Nut                 | 27. | 110667 | 1/4 Lock washer                 |
| 14. | OEM    | Wire                |     |        |                                 |

**FIG. 1**  
**BELT DIAGRAM**



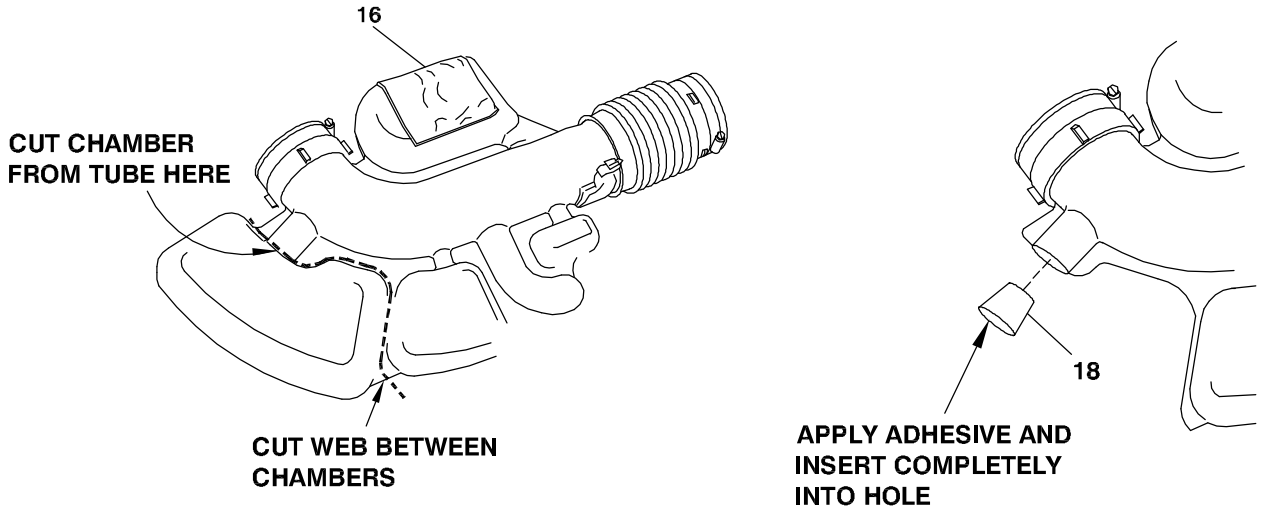
**FIG. 4**  
**MODIFY ALTERNATOR BRACKET 2009**



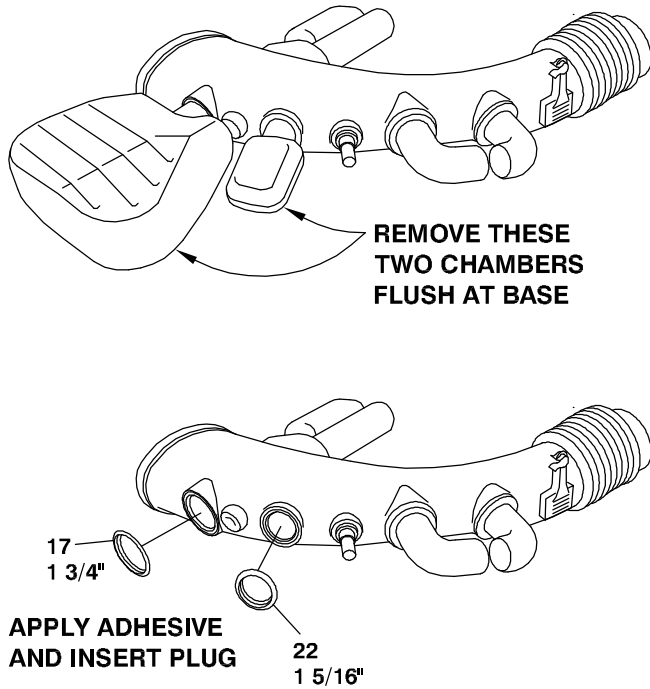


**FIG. 2**

**FIG. 3) 5.4L AIRBOX MODIFICATION**



**6.8L AIRBOX MODIFICATION**



# DewEZE Clutch Pump Kit 700545

Ford 5.4L, 6.8L, A Pump, PH14, 2008+

## INSTALLATION INSTRUCTIONS

1. The installation of this kit requires trained decision-making concerning clearances, tying components together, rerouting, or relocating OEM components, etc. It is impossible to describe all of the clearance and vibration points, etc. in the installation instructions. Therefore, the technician must exercise professional judgment to achieve the best quality installation.
2. Disconnect the battery.
3. Loosen clamps at the end of the large plastic airbox and remove airbox.
4. Remove the OEM belt.
5. On 2009 and later trucks, remove the OEM bracket over the top of the alternator. Cut the bracket along the dotted line and discard the shaded portion as in Fig. 4. Reinstall this bracket. Place the bridge plate (19) on top of the alternator bracket (from Location D to Location E), using the OEM bolts (20, 21).
6. Remove OEM idler pulley (12) to gain access to mounting bolt at location B. Keep the pulley and bolt.
7. Remove nut (13) holding wire at location A. Remove stud bolt (6) at location A. Remove OEM bolt at location B.
8. Install the hose adapters into the pump ports. Bolt pump (3) onto pump plate (1) with two 3/8 x 1 flange bolts (9). Attach coil (4a) with four 1/4 x 1/2 flange bolts (4b). Torque these to 6 ft-lb. Attach clutch pulley (4c) to pump shaft with 5/16NF x 1 1/4 bolt (4d) and heavy washer (4e). Torque to 14 ft-lb.
9. Attach the idler pulley (5) to the boss on the front of the pump mount bracket (1) at

Location C with the M10 x 60 bolt (8). Torque to 19-25 ft-lb.

10. See Fig. 5. Disconnect the wiring from the alternator, pull it from the attachment points on the valve cover and push it back on top of the valve cover. Make sure the alternator wiring will not be pinched between the engine and pump bracket when it is installed.

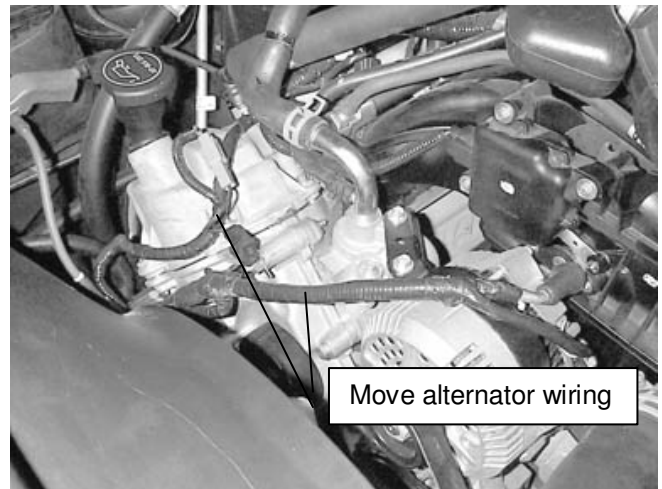


Fig. 5

11. Attach the pump mount bracket (1) to the engine with the OEM stud bolt (6) at Location A and the M8 x 60 (7) bolt at Location B. Torque these bolts to 19-25 ft-lb.
12. Reinstall OEM idler (12) using the OEM bolt in its original location. Torque to 19-25 ft-lb.
13. Install the serpentine pump drive belt (15) per diagram.

14. Replace the wire (14) on the stud bolt (6) rotating it 180 degrees from the OEM position so it points away from the pump bracket so it is not in the belt line. See Fig. 6.



Fig. 6

15. Set the airbox in place and check to see if it contacts the pump or bracket. If it does, it is necessary to remove part of the airbox for clearance.

On the **5.4L** engine airbox, the large chamber on the passenger end that interferes with the pump must be removed. Cut the web between the chambers and the main tube. Cut the chamber from the tube leaving about one inch of tube. Apply a heat-resistant adhesive to the tapered silicone plug (18) and insert completely into hole.

On the **6.8L** engine airbox, remove the two chambers flush at the base where they connect to main tube. Apply a heat-resistant adhesive to the recessed button plugs (17 and 22) and press firmly into their appropriate hole.

16. Replace the air box (16) and re-tighten the two clamps.
17. Connect the battery.
18. Run the engine and check for any clearance or alignment problems. Adjust as needed.