

2

1

B

B

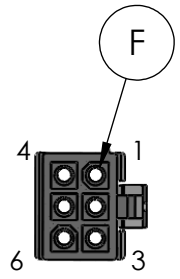
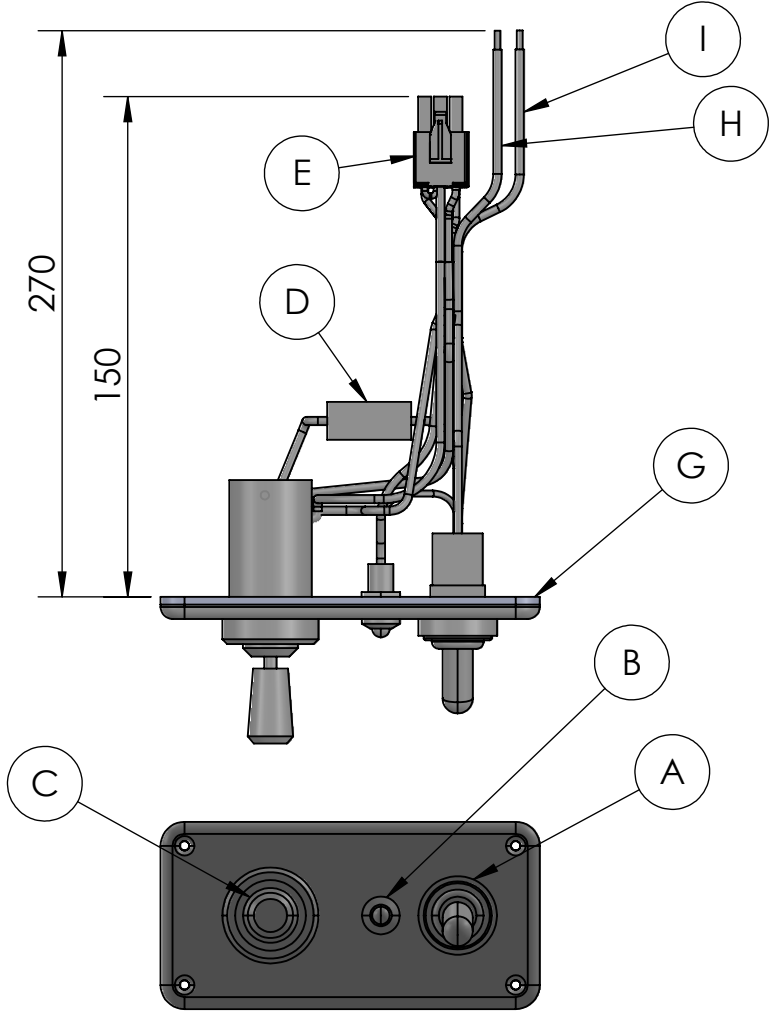

PIN ASSIGNMENTS

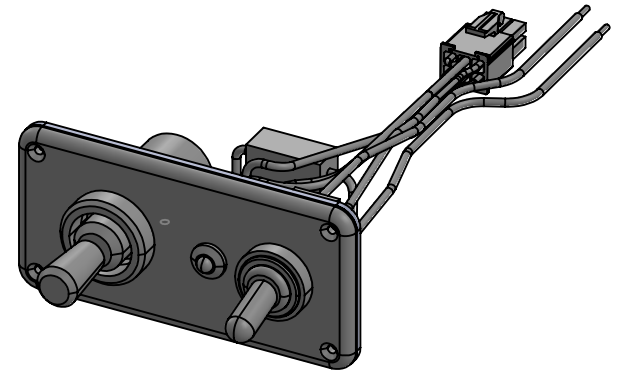

PIN NO.	COLOR	SIZE	FUNCTION
1	RED	18 AWG	+ LAMP
2	WHITE	18 AWG	- VERTICAL MOTOR
3	WHITE	22 AWG	- HORIZONTAL MOTOR - JUMPER FROM PIN#2
4	BLACK	18 AWG	- LAMP
5	GREEN	18 AWG	+ HORIZONTAL MOTOR
6	YELLOW	18 AWG	+ VERTICAL MOTOR

NOTES:

- WIRES NOT DRAWN TO SCALE - ACTUAL LENGTH LONGER THAN ILLUSTRATED
- ITEMS H AND I ARE INSULATED WIRE WITH STRIPPED AND TINNED ENDS

A

A

ITEM	PART NO.	DESCRIPTION	QTY
I		BLACK WIRE - 18 AWG - CHASSIS GROUND	1
H		RED WIRE - 18 AWG - 12V POSITIVE	1
G		GASKET - 2 MM THICK	1
F	GT-2020-2531	FEMALE SOCKET - AMP 170361-1	6
E	GT-2020-2530	MALE PLUG - AMP 172339-1	1
D		RESISTOR - 5W/15 OHM	1
C		DIRECTIONAL CONTROL - 4-WAY	1
B		INDICATOR LIGHT - LED	1
A		TOGGLE SWITCH - SPST	1



PROPRIETARY AND CONFIDENTIAL
THE INFORMATION CONTAINED IN THIS DRAWING IS THE SOLE PROPERTY OF GOLIGHT, INC. ANY REPRODUCTION IN PART OR AS A WHOLE WITHOUT THE WRITTEN PERMISSION OF GOLIGHT, INC IS PROHIBITED.

DO NOT SCALE DRAWING

GOLIGHT, INC 37146 OLD HWY 17 CULBERTSON, NE 69024 800.557.0098 www.golight.com		
UNLESS OTHERWISE SPECIFIED: DIMENSIONS ARE IN MM TOLERANCES: FRACTIONAL ± ANGULAR: MACH ± BEND ± TWO PLACE DECIMAL ± THREE PLACE DECIMAL ±		
DRAWN	B R BAIR	9/18/2019
CHECKED	C D HOSICK	9/18/2019

PART NUMBER: GT-2020-D		
TITLE: ASSY - REMOTE - HARDWIRED DASH - GT		
SIZE A	DWG. NO. 10061	REV NONE
SCALE: NONE		SHEET 1 OF 1

2

1