

Tool Box Mounting Instructions

Please read these instructions and warnings before installation.

DANGER

Do not use this toolbox for the storage or transportation of flammables, explosives, hazardous waste or materials such as gasoline, solvents, gun powder, dynamite, propane tanks, acetylene tanks or cutting torches. This toolbox is only intended and safe for use in storing and transporting small tools and equipment.

WARNING

- If the proper mounting brackets are not used, the toolbox could drop off the vehicle while it is moving and cause personal injury and/or property damage.
- Mounting your toolbox through the top, back or sides without bottom support will significantly reduce the capacity and the life of the toolbox. The truck toolbox must be mounted with the bottom fully supported or structural damage can occur to the toolbox.
- Prior to any welding or drilling holes in a vehicle frame, check for location of fuel tanks, fuel lines, brake lines or electrical wires.
- If welding is to be done on a vehicle frame in the mounting of this toolbox, disconnect the cables from the battery to prevent shorting of electrical components on the vehicle.
- Always wear protective eye wear when drilling, welding or checking the underside of a vehicle.

This truck toolbox may be mounted on various truck types and chassis styles which may require alternative ways to attach the brackets to the vehicle.

Buyers Products recommends the use of Buyers Products support mounting brackets (see next page for the part number of the mounting brackets to fit your box) with adequate frame support to properly mount your truck toolbox (as shown below).

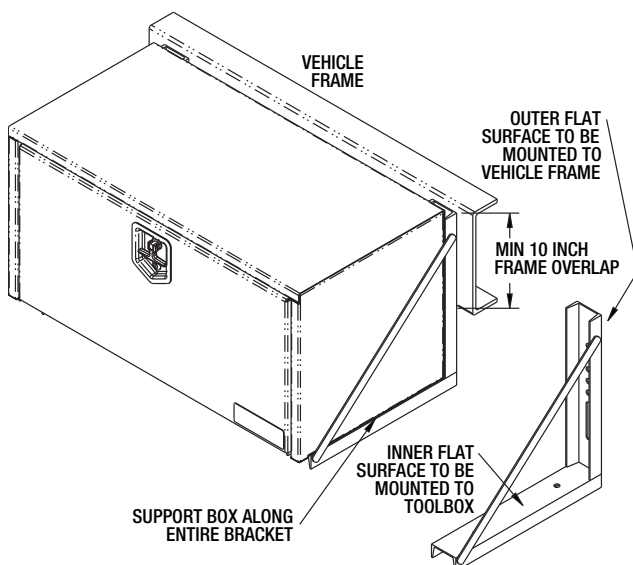

Additional fabrication may be necessary to complete this installation. Buyers Products Co. recommends contacting a qualified and trained truck equipment dealer for installation. Install fasteners with threadlocker adhesive and follow the manufacturer instructions for its application. After mounting the toolbox, apply silicone sealant all around each fastener to prevent leaks, and touchup drilled holes with aerosol paint to prevent rust.

A final latch adjustment after installation of your toolbox on the truck will ensure the latches are fine-tuned to your box configuration. Review the information below or scan the QR Code to watch our YouTube tutorial on adjusting our most popular latches

Toolbox Maintenance

1. Inspect Latch hardware monthly to ensure proper performance.

Paddle Latch - Locate the striker post on the top panel of the toolbox. Loosen the adjustment nut, slide to the proper position moving the striker further into the box to tighten the latch. Re-tighten nut to secure the striker.

T-Handle - Adjust cam arm on backside of latch by loosening the two nuts on the shank. To tighten, loosen the near nut first, slide the cam up to that nut and then tighten the far nut onto the cam.

T-Handle with Roller - Compress the cam arm by hand (moving it towards you) and adjust the single nut to desired position (moving the nut towards you to tighten the latch). The cam arm will lock around nut when re-seated.

2. Check Mounting hardware monthly. The fasteners are subjected to vibration and can loosen over time.

3. Lubricate the truck toolbox hinge twice per year.

4. Inspect gaskets for damage, wear or tears twice per year. Replace if necessary.



This step-by-step instructional video details how to adjust and tighten our most popular truck toolbox latches.

Mounting Brackets

PART NO.	DIMENSIONS	DESCRIPTION
STEEL MOUNTING BRACKETS		
1701005	18" x 18"	Steel Structural Welded Brackets
1701010	18" x 24"	Steel Structural Welded Brackets
1701015	24" x 24"	Steel Structural Welded Brackets
1701005B	18" x 18"	Steel Structural Bolted Brackets
1701010B	18" x 24"	Steel Structural Bolted Brackets
1701006	18" x 18"	Steel Formed Welded Brackets
1701011	18" x 24"	Steel Formed Welded Brackets
1701016	24" x 24"	Steel Formed Welded Brackets
1701006B	18" x 18"	Steel Formed Bolted Brackets
1701011B	18" x 24"	Steel Formed Bolted Brackets
ALUMINUM MOUNTING BRACKETS		
1701030	18" x 18"	Aluminum Brackets
1701040	24" x 24"	Aluminum Brackets
STAINLESS STEEL MOUNTING BRACKETS		
1701031	18" x 18"	Stainless Brackets
1701041	18" x 24"	Stainless Brackets

Common Latches

PART NO.	INFO	DESCRIPTION
L8816	Locking	T-Handle Latch, Stainless
	88CH545	Replacement Cylinder
	CH545	Replacement Key
	L881XGO	Replacement Gasket
L3890RLS	Locking	Paddle Latch, Stainless
	CH545	Replacement Key
	L881XGO	Replacement Gasket
LL9000	Locking	Die Cast T-handle
	88CH545	Replacement Cylinder
	CH545	Replacement Key
	3036319	Replacement Gasket LL9000
LL90003	Locking	3-Point Die Cast T-handle
	88CH545	Replacement Cylinder
	CH545	Replacement Key
	3036319	Replacement Gasket LL9000
	3024136	7.60" individual rod for use in 3-Point Latch for 18" enclosure
	3024137	10.60" individual rod for use in 3-Point Latch for 24" enclosure
	3024138	13.60" individual rod for use in 3-Point Latch for 30" enclosure
	3024139	16.60" individual rod for use in 3-Point Latch for 36" enclosure
	3030564	22.60" individual rod for use in 3-Point Latch for 48" enclosure
	3031368	28.60" individual rod for use in 3-Point Latch for 60" enclosure

Universal Accessories

PART NO.	DESCRIPTION
1701072	Universal Shelf Kit for 18x18x36 Underbody Truck Tool Boxes
1701077	Universal Shelf Kit for 18x18x48 Underbody Truck Tool Boxes
1701082	Universal Shelf Kit for 18x18x60 Underbody Truck Tool Boxes
1701062	Universal Heavy-Duty Truck Tool Box and Shelf Liner
DM1212B	Universal Heavy-Duty Interlocking Shelf Liner and Floor Tile

WARRANTY

Buyers Products Co. warrants all truck/trailer hardware manufactured or distributed by it, to be free from defects in material and workmanship for a period of one year from date of shipment. Parts must be properly installed and used under normal conditions. Any product which has been altered, including modification, misuse, accident or lack of maintenance will not be considered under warranty. Normal wear is excluded. The sole responsibility of Buyers Products Co. under this warranty is limited to repairing or replacing any part or parts which are returned, prepaid, and are found to be defective by Buyers Products Co. Authorization from Buyers Products Co. must be obtained before returning any part. No charges for transportation or labor performed on Buyers' products will be allowed under this warranty.