



WORKLIGHTS



EW2510 SERIES

Nine 10-Watt LEDs

EW2510 Series heavy-duty worklights offer the latest technology and the very brightest white light for your application. These LED models offer over 80,000 hours of maintenance free life expectancy coupled with very low amp draw. A robust housing with vibration dampening bracket and high-intensity 5000 lumen light output make these worklights the ideal choice for a wide variety of arduous applications. Features 12-24 VDC operation, a choice of flood or spot beams, aluminum housing and a 5-year warranty.

Models

PART NO.	TYPE	LUMENS (RAW)	VDC	AMPS
EW2510	Spot	5,100	12-24	4.8
EW2511	Flood	5,000	12-24	4.8

Design Features

- Vibration-Protected Bracket
- Nine 10-watt LEDs
- High-intensity beam
- Vibration dampening bracket
- Aluminum heatsink housing
- Polycarbonate lens

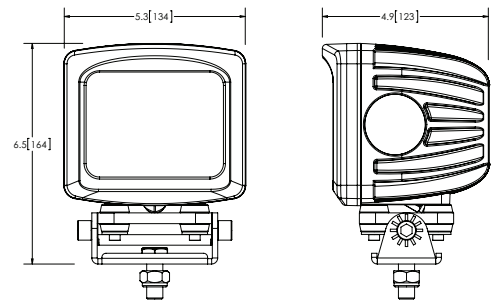

Beam Pattern

