

FFFL112**FREIGHTLINER**

Front suspension package
Ensemble pour suspension avant
Ensemble para suspensión de delantero

INSTALLATION INSTRUCTIONS

- Raise vehicle allowing the axle to hang freely.
- Remove top shock mounting bolts.
- Assemble Aeon rubber spring and bracket as shown in the adjacent diagram.
- Mount Timbren spring assembly between shock mount bracket and chassis frame.
- Tighten using Timbren fasteners provided & torque to OEM specifications.
- Lower vehicle.

INSTRUCTIONS DE MONTAGE

- Soulever le véhicule de sorte que l'essieu soit dégagé.
- Retirer les boulons supérieurs du montage élastique.
- Assembler le ressort en caoutchouc Aeon et le support comme il est indiqué dans le schéma adjacent.
- Monter le bloc de ressorts Timbren entre le support d'amortisseur et le cadre de châssis.
- Resserrer à l'aide de la boulonnerie fournie avec l'assemblage Timbren - effectuer une torsion selon les spécifications du fabricant d'équipement.
- Redescendre le véhicule.

INSTRUCCIONES DE INSTALACIÓN

- Levante el vehículo dejando que los ejes cuelguen libremente.
- Retire los pernos de montaje superiores del amortiguador.
- Ensamble el resorte de caucho Aeon y la abrazadera como se muestra en el diagrama adyacente.
- Monte la unidad de resorte Timbren entre la abrazadera de montaje del amortiguador y el armazón del chasis.
- Apriete utilizando los elementos de sujeción Timbren provistos - aplique par de torsión según las especificaciones del fabricante original de equipo.
- Baje el vehículo.

Do not exceed vehicle manufacturer's recommended axle weight rating. Check for AEON[®] interference with vehicle components - Under load AEON[®] will "expand" in diameter.

Ne pas dépasser le poids nominal sur l'essieu recommandé par le fabricant du véhicule. Vérifier que le ressort AEON[®] n'a pas d'incidence sur d'autres pièces du véhicule - Le ressort AEON[®] augmentera son diamètre avec la charge.

No exceda la carga nominal en el eje recomendada por el fabricante del vehículo. Compruebe que no haya interferencia entre el resorte AEON[®] y los otros componentes del vehículo. Bajo carga, el resorte AEON[®] se ampliará en diámetro.

Ref. = Reference = No. de référence = Núm. de referencia
Part = Part #. = No. de pièce = Núm. de pieza
Qty. = Quantity = Quantité = Cantidad

Ref	Part	Qty
1	F31007-150	4
2	F40071-020	4
3	F11146-150	4
4	K10276-003	1L-1R
5	A00540-65E60	2
6	F11104-150	2

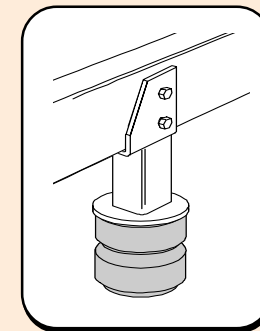
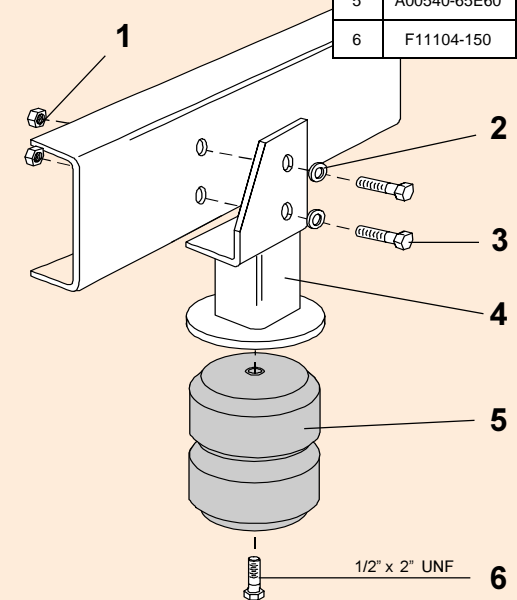

FFFL112

FFFL112

TIMBREN INDUSTRIES INC.

www.timbren.com

PART NUMBER	DESCRIPTION	QTY	LOCATION
F31007-150	NYLOCK LOCKNUT 5/8 UNF GR 5 Z	4	H2E
F40071-020	WASHER FLAT USS 5/8 x 1-3/4 GR 2 Z	4	H2E
F11146-150	HCS 5/8 x 2-1/2 UNF GR 5 Z	4	H2E
F11104-150	HCS 1/2 x 2 UNF GR 5 Z	2	G1D

A00540-65E60	Hollow Rubber Spring	2	C8B
--------------	----------------------	---	-----

K10276LH-003	FFFL112 WELDMENT LH PAINTED	1	E3B
K10276RH-003	FFFL112 WELDMENT RH PAINTED	1	E3B

B90224	12 x 11 x 8-1/2" DW Carton	1	A1A
B10100	NEWSPRINT 18" ROLL	1	
B00029-010	BARCODE LABEL FOR KIT	1	

Issued: 10/20/2006

Clearance Instructions:

Rear SES Kits for Pick-Ups and Vans should have a 1/2" to 1-1/2" gap between the rubber spring and contact point when empty.

A partial load, or vehicle accessories will reduce or eliminate the gap.

Front SES kits are usually in full contact.

Medium and Heavy-Duty Trucks, Trailers and Motorhomes will be in constant contact, and have no gap.

Lifetime Warranty:

Timbren SES Kits are warranted against defects in material and workmanship, under normal use and service, for the life of the vehicle on which the kit was originally installed. The warranty is not transferable and proof of purchase is required. The warranty is limited to the replacement of the failed part.

TIMBREN will not be responsible for any labour or freight charges involved in the replacement of any product. TIMBREN shall be entitled to make its own inspection to determine the validity of the claim. TIMBREN shall not be liable nor warranty the product in the event of alteration, misuse, overload, negligence or damage caused by others.

If ride or performance of our product is unsatisfactory in any way, please call: 1-800-263-3113 or email sales@timbren.com

ASSEMBLY NOTES:

APPLY 'LEFT' LABEL TO L/H BRACKET.