

# Industrial Winch Selection Guide



[ramsey.com](http://ramsey.com)

CHOICE OF PROFESSIONALS





## Table of Contents

Hydraulic Worm Gear Winches .....	4-5
Hydraulic Planetary Gear Winches.....	6-7
Heavy Duty Electric Worm Gear Winches.....	8-9
Extended Shaft Winches .....	10-11
Worm Gear Speed Reducers .....	12-13
Options for Ramsey Hydraulic Worm Gear Winches and Planetary Hydraulic Winches.....	14-15

## How to Select a Winch

1. Determine the line pull required.
2. Determine the size (diameter) and length of cable required.
3. Where will the line load occur—on the first layer of cable on the drum barrel? The second? The third?
4. Select the proper winch model and determine the first layer rating required (all performance charts in this brochure are based on the first layer line pull ratings. All winches are rated based on first layer).

**EXAMPLE:** Customer A has an application that requires a 5,000 lbs. line pull and have selected 80 ft. (24.3m) of 3/8 inch (9mm) diameter cable as the optimum length. This application would require a low mount hydraulic winch.

Referring to the performance data for low mount hydraulic winches on page 5, 80 ft. of 3/8 cable will build up to three layers on a model H-200 winch and the winch provides 5,700 lbs. (2,580 kgs) maximum allowable line pull on the third layer. The line speed on this layer would be 17.5 ft./min. at the maximum hydraulic system flow of 15 GPM. Line speed on the first layer would be 12.6 ft./min. Also, note that the required hydraulic system pressure is 1,550 PSI minimum.

Customer A would therefore select our Model H-200 winch with 8,000 lbs. first layer line pull rating as the best choice.

\*For performance using wire sizes other than the recommended size, contact the factory.

## WARNING

Winches are not to be used to lift, support or otherwise transport personnel. A minimum of five (5) wraps of cable around the drum is necessary to support the rated load. Cable clamp is not designed to hold the load.

## Limited Warranty Excerpt

Ramsey Winch warrants each new winch and speed reducer to be free from defects in workmanship for a period of one (1) year from date of purchase. The obligation under this warranty, statutory or otherwise, is limited to the replacement or repair at our factory of such part or parts as shall appear to us upon inspection to be defective in materials and workmanship. Complete warranty statement packed with each item.





# Hydraulic Worm Gear Selection Chart

## Performance Data

Winch Rating (LBS)	Winch Model	Recommended Wire Rope Size (INCH) (MM)	Minimum System Pressure for Rated Pull (PSI)	Maximum System Flow (GPM)	Worm Gear Ratio	1st Layer			2nd Layer			3rd Layer			4th Layer			5th Layer		
						Line Pull (LBS) (KGS)	Cable Cap. (Ft) (M)	Line Speed (FPM) (MPM)	Line Pull (LBS) (KGS)	Cable Cap. (Ft) (M)	Line Speed (FPM) (MPM)	Line Pull (LBS) (KGS)	Cable Cap. (Ft) (M)	Line Speed (FPM) (MPM)	Line Pull (LBS) (KGS)	Cable Cap. (Ft) (M)	Line Speed (FPM) (MPM)	Line Pull (LBS) (KGS)	Cable Cap. (Ft) (M)	Line Speed (FPM) (MPM)
* 3000	H-7	1/4 6	750	15	38:1	3000 1350	10 3.0	16 5.0	2600 1170	20 6.0	19 5.8	2200 900	35 10.0	21 6.3	2000 900	50 15.0	24 7.2	1800 810	70 21.0	27 8.2
* 3000	HX-7	1/4 6	750	15	38:1	3000 1350	15 4.0	16 5.0	2600 1170	40 12.0	19 5.8	2200 900	65 19.0	21 6.3	2000 900	95 28.0	24 7.2	1800 810	125 38.0	27 8.2
* 8000	H-8B	5/16 8	1000	15	38:1	4000 1810	15 4.0	17 5.1	3300 1490	30 9.0	20 6.0	2900 1310	55 16.0	23 6.9	2500 1130	80 24.0	26 7.9			
8000	H-200 HY-200	3/8 9	1600	15	60:1	8000 3620	25 8.0 15 4.0	12 3.8	6700 3030	60 18.0 30 9.0	15 4.5	5700 2580	95 30.0 55 16.0	17 5.3	5000 2260	140 43.0 75 22.0	20 6.0			
8000	H-246 HY-246	3/8 9	1800	15	46:1	8000 3620	25 8.0 15 4.0	16 5.0	6700 3030	60 18.0 30 9.0	19 5.9	5700 2580	95 30.0 55 16.0	22 6.6	5000 2260	140 43.0 75 22.0	26 7.9			
8000	HD-200 HDY-200	3/8 9	1700	15	30:1	8000 3620	25 8.0 15 4.0	32 9.7	6700 3030	60 18.0 30 9.0	38 11.5	5600 2520	95 30.0 55 16.0	45 13.7	5000 2260	140 43.0 75 22.0	51 15.5			
8000	HD-200 HDY-200	3/8 9	2500	15	30:1	8000 3620	25 8.0 15 4.0	32 9.7	6700 3030	60 18.0 30 9.0	38 11.5	5600 2520	95 30.0 55 16.0	45 13.7	5000 2260	140 43.0 75 22.0	51 15.5			
8000	HD-234 HDY-234	3/8 9	2375	15	34:1	8000 3620	25 8.0 15 4.0	28 8.5	6700 3030	60 18.0 30 9.0	34 10.3	5700 2610	95 30.0 55 16.0	39 11.8	5000 2260	140 43.0 75 22.0	44 13.3			
9000	H-300 HY-300	3/8 9	1750	15	60:1	9000 4070	25 8.0 15 4.0	12 3.8	7500 3390	60 18.0 30 9.0	15 4.5	6400 2890	95 30.0 55 16.0	17 5.3	5600 2530	140 43.0 75 22.0	20 6.0			
9000	H-346 HY-346	3/8 9	2000	15	46:1	9000 4070	25 8.0 15 4.0	16 5.0	7500 3390	60 18.0 30 9.0	19 5.9	6400 2890	95 30.0 55 16.0	22 6.6	5600 2530	140 43.0 75 22.0	26 7.9			
A A 10,000	HDG-350 HDGY-350	7/16 11	2100	15	30:1	10,000 4540	20 6.0 15 4.0	32 9.7	8100 3670	50 15.0 30 9.0	38 11.5	6900 3120	85 25.0 55 16.0	44 13.3						
A* A* 10,000	H-400 HG-400	7/16 11	2800	23	29:1	10,000 4540	25 7.0	30 10.0	8200 3710	55 16.0	40 12.0	6900 3120	90 27.0	53 16.0	6000 2710	130 39.0	53 16.0			
A* A* 10,000	HY-400 HGY-400	7/16 11	3000	23	29:1	10,000 4540	20 6.0	33 10.5	8300 3760	45 13.0	40 12.3	7100 3210	70 21.0	47 14.5	6200 2800	105 31.0	54 16.0			
A* A* 12,000	H-600 HY-600 HX-600	1/2 13	2750	25	40:1	12,000 5430	20 6.0 15 4.0 30 9.0	25 7.6	9800 4430	55 16.0 40 12.0 65 19.0	31 9.4	8300 3750	90 27.0 65 19.0 110 33.0	37 11.2	7200 3260	130 39.0 95 28.0 165 50.0	42 12.7	6300 2850	180 54.0 135 39.0 225.0 68.0	48 14.5
A* A* 15,000	H-700 HX-700	9/16 14	2750	30	35:1	15,000 6790	20 6.0 35 10.0	27 8.2	12,300 5570	50 15.0 75 22.0	33 10.0	10,500 4750	85 25.0 125 38.0	38 11.5	9100 4120	125 38.0 185 56.0	44 13.3	8100 3660	170 51.0 250 76.0	50 15.2
20,000	H-800 HY-800	5/8 16	2200	30	40:1	20,000 9060	35 10.0 20 6.0	18 5.4 18 5.5	16,600 7520	75 22.0 45 13.0	22 6.6 21 6.3	14,200 6430	125 38.0 75 22.0	26 7.9 25 7.6	12,400 5610	180 54 110 33	29 8.8 28 8.5	11,000 4980	240 72.0 150 45.0	33 10.0 31 9.4
30,000	H-930	3/4 19	2500	35	41:1	30,000 13,590	25 7.0	13 3.9	24,500 11,090	65 19.0	17 5.3	20,700 9370	105 31.0	20 6.0	18,000 8150	155 47.0	24 7.2			

\* Last layer does not conform to SAE Standard J706.  
A-Standard rating listed. Higher SAE J706 ratings available—contact factory.



# Hydraulic Planetary Gear Winches



Ramsey Industrial Hydraulic Planetary Winches are developed to meet a need for increased line speed for vehicle recovery and other industrial uses. Winches feature easy free spooling, single lubricant for all temperature ranges and light weight. For more information, see Planetary Hydraulic Winch Brochure.

- Ramsey Level Winders available for HD-P 8,000 HD-P 10,000 & RPH 12,000
- Ramsey Air Tensioners Available for RPH 15,000; RPH 20,000; RPH 25,000; RPH 30,000; RPH 35,000; RPH 45,000 RPH 50,000
- Optional Air Shift Clutch available

WINCH MODEL	A INCHES MM	B INCHES MM	C INCHES MM	D INCHES MM	E INCHES MM	F INCHES MM
HD-P 8,000 STD. DRUM	9.75 247,7	12.25 311,2	8.87 225,3	14.60 370,9	13.28 337,4	27.89 708,3
HD-P 8,000 "Y" DRUM	6.50 165,1	9.00 228,6	7.24 184,0	12.98 329,6	11.66 296,2	24.64 625,8

## HD-P 8,000 – Dimensions

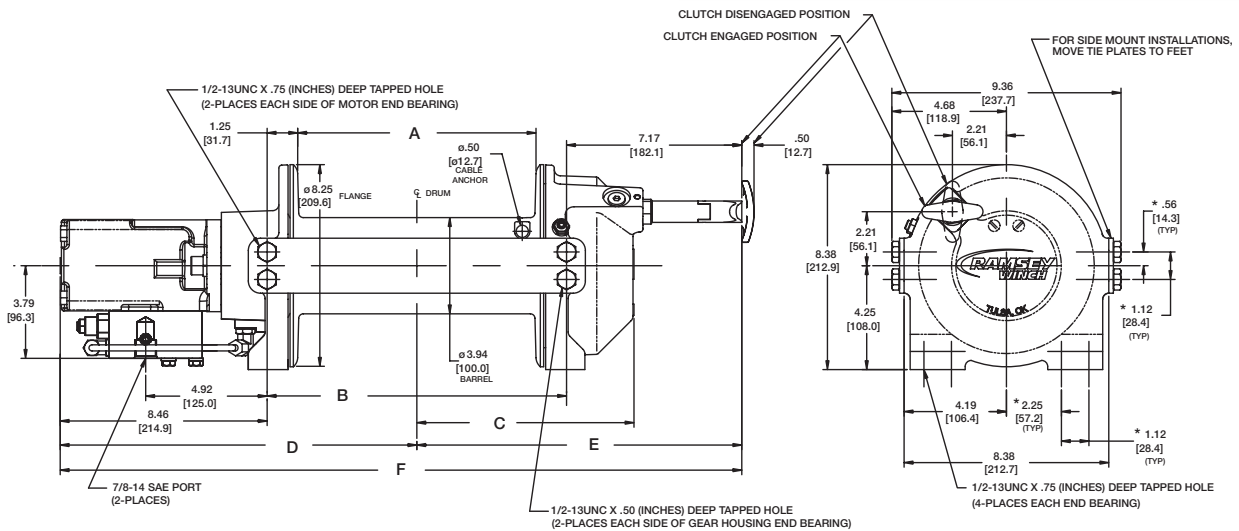

DIMENSIONS SHOWN ARE INCHES OVER MILLIMETERS

WINCH MOUNTING CAPSCREWS MUST MEET OR EXCEED SAE GRADE 5 SPECIFICATION

\*NOTE: THESE HOLE LOCATIONS MUST BE HELD WITHIN .03" (0.8 MM) OF TRUE POSITION. RECOMMENDED MOUNTING HOLE DIAMETER IS .53" (13.5 MM).

## RPH 50,000 – Dimensions

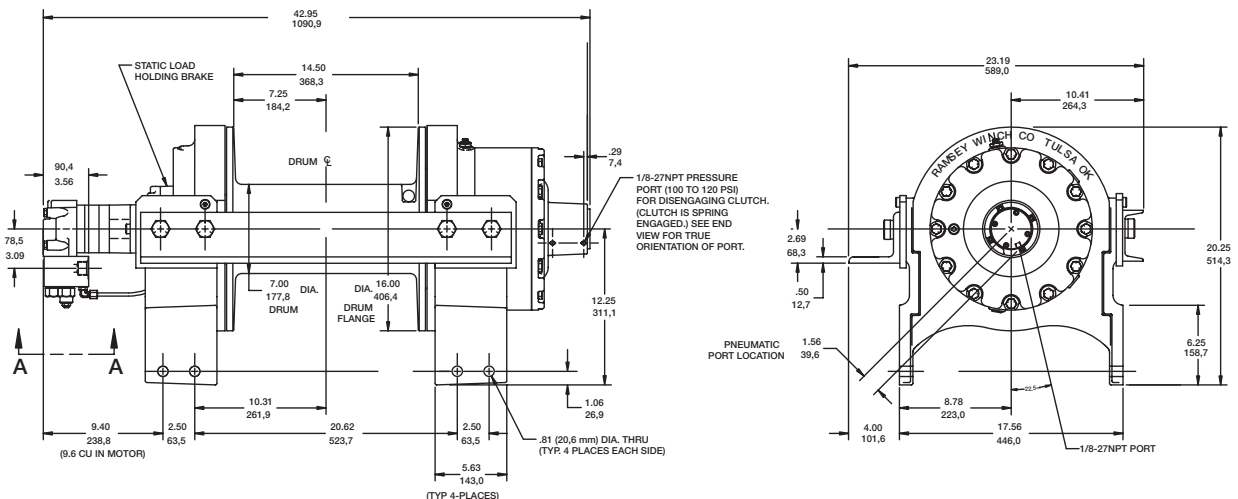

DIMENSIONS SHOWN ARE INCHES OVER MILLIMETERS



# Hydraulic Planetary Gear Selection Chart

## Performance Data

Winch Rating (LBS)	Winch Model	Recommended Wire Rope Size (INCH) (MM)	Hydraulic Pressure Required For Rated Line Pull (PSI)	Hydraulic Flow Required For Rated Line Speed (GPM)	Gear Ratio	Weight without cable (LBS) (KGS)	1st Layer			2nd Layer			3rd Layer			4th Layer			5th Layer			6th Layer			
							Line Pull (LBS) (KGS)	Cable Cap. (Ft) (M)	Line Speed (FPM) (MPM)	Line Pull (LBS) (KGS)	Cable Cap. (Ft) (M)	Line Speed (FPM) (MPM)	Line Pull (LBS) (KGS)	Cable Cap. (Ft) (M)	Line Speed (FPM) (MPM)	Line Pull (LBS) (KGS)	Cable Cap. (Ft) (M)	Line Speed (FPM) (MPM)	Line Pull (LBS) (KGS)	Cable Cap. (Ft) (M)	Line Speed (FPM) (MPM)	Line Pull (LBS) (KGS)	Cable Cap. (Ft) (M)	Line Speed (FPM) (MPM)	
8,000	HD-P 8,000-S HD-P 8,000-Y	3/8 10	2500	15	5.1:1	82	25	50	6800	55	58	5900	90	67	5200	130	76	4700	170	84					
						37	7.0	15	16.0	35	17.6	27.0	39.0	51.0	51.0	115	23.1	2120	34.0	25.5					
						76	15	4.0	3080	10.0	20.3	2350	25.0												
10,000	HD-P 10,000-S HD-P 10,000-Y	7/16 11	2100	15	5.1:1	87	20	32	8300	50	38	7100	80	44	6200	115	51								
						40	6.0	9.8	3760	15.0	11.6	24.0	35.0	15.0	13.4	2810	22.0								
12,000	RPH 12,000	7/16 11	2500	15	5.1:1	110	12,000	20	32	10,000	50	38	8500	80	44	7500	115	51	6600	160	57				
						50	5440	6.0	9.7	4530	15.0	11.5	3850	24.0	13.4	3400	35.0	15.5	2990	48.0	17.3				
* 15,000	RPH 15,000	1/2 13	2400	15	7.7:1	300	15,000	35	25	12,600	75	29	10,800	125	34	9500	180	39	8500	240	44	7600	310	48	
						136	6800	10.0	7.6	5710	22.0	8.8	4890	38.0	10.3	4300	54.0	11.8	3850	73.0	13.4	3440	94.0	14.6	
* 20,000	RPH 20,000	9/16 14	2500	15	25.53:1	375	20,000	35	26	16,900	85	30	14,700	135	35	13,000	195	39	11,600	265	44				
						170	9070	10.0	7.9	7660	25.0	9.1	6660	41.0	10.6	5890	59.0	11.8	5260	80.0	13.4				
* 25,000	RPH 25,000	5/8 16	3000	15	25.53:1	380	25,000	35	27	20,800	75	31	17,900	125	36	15,600	185	41	13,900	245	46				
						172	11,340	10.0	8.3	9430	22.0	9.5	8110	38.0	11.1	7070	56.0	11.8	6300	74.0	14.0				
* 30,000	RPH 30,000	5/8 16	2800	15	31.89:1	486	30,000	30	19	25,200	75	23	21,700	120	26	19,100	175	29	17,000	235	33	15,400	300	36	
						220	13,605	9.0	5.7	11,430	22.0	7.0	9840	36.0	7.9	8660	53.0	8.8	7700	71.0	10.0	6980	91.0	10.9	
* 35,000	RPH 35,000	3/4 19	2650	15	31.89:1	568	35,000	25	15	28,600	60	18	24,200	105	21	21,000	155	23	18,500	200	28				
						258	15,909	7.60	4.6	13,000	18.3	5.5	11,000	32.0	6.4	9545	47.2	7.0	8390	60.0	8.5				
* 45,000	RPH 45,000	3/4 19	2800	25	51.35:1	689	45,000	35	23	37,700	75	27	32,400	125	32	28,500	180	36	25,300	245	40	22,900	310	45	
						313	20,380	10.0	7.0	17,100	22.0	8.2	14690	38.0	9.8	12,920	54.0	11.0	11,460	74.0	12.2	10,380	94.0	13.7	
* 50,000	RPH 50,000	7/8 22	3000	25	51.35:1	689	50,000	30	23	40,900	65	28	34,600	110	33	30,000	160	38	26,400	220	43				
						313	22,670	9.0	7.0	18,550	19.0	8.6	15,690	33.0	10.1	13,600	48.0	11.7	11,970	66.0	13.2				

\* Last layer does not conform to SAE Standard J706.



# Electric Worm Gear Winches



All Ramsey Worm Gear Drive Heavy Duty Electric Winches are available for either 12 volt or 24 volt systems, to meet a wide variety of application requirements. Line pull ratings range from 3,000 to 9,000 lbs. Features include forward and reverse operation, optional gear ratios, optional drum ratios, optional drum sizes, all moving parts completely enclosed for maximum protection and longer wear.

Free-spooling is available on all but the DC7 Models.  
Blocked clutches are an option on some models.

For more information, see Electric Worm Gear Winch Brochure.

- Ramsey Level Winders available (Models DC-200, DC-246, DC-300 and DC-346)

WINCH MODEL	A INCHES MM	B INCHES MM	C INCHES MM	D INCHES MM
DC-200	7.78 197.6	11.31 287.3	8.94 227.0	13.12 333.3
DCY-200	5.28 134.1	6.31 160.3	11.44 290.5	8.12 206.3

## DC-200 RAM-LOK® – Dimensions

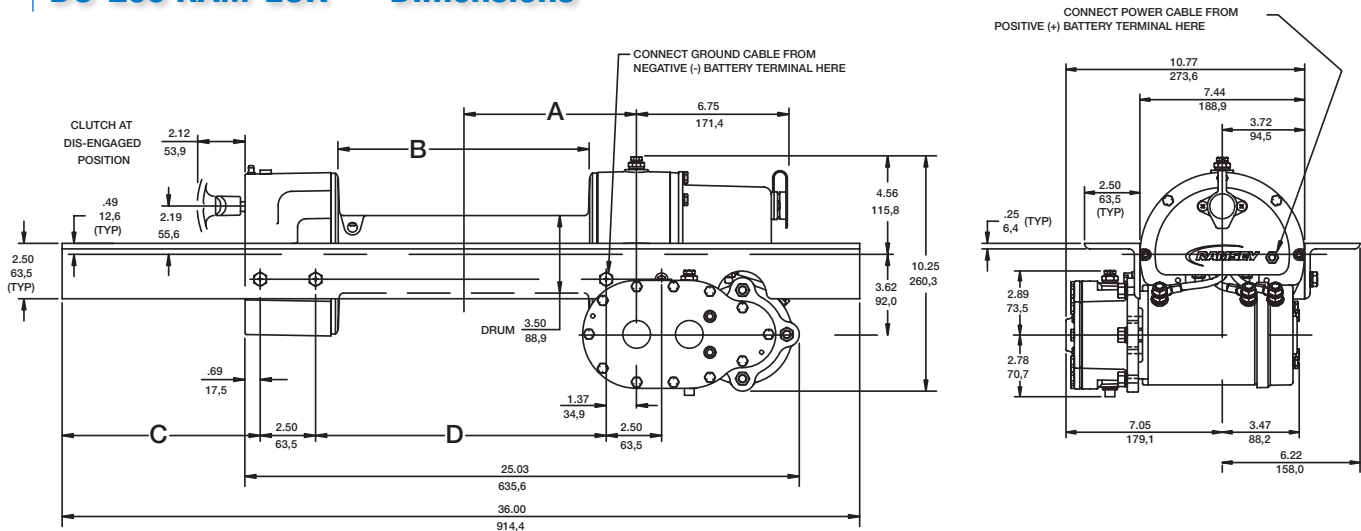

## DC-200 Lever Style – Dimensions

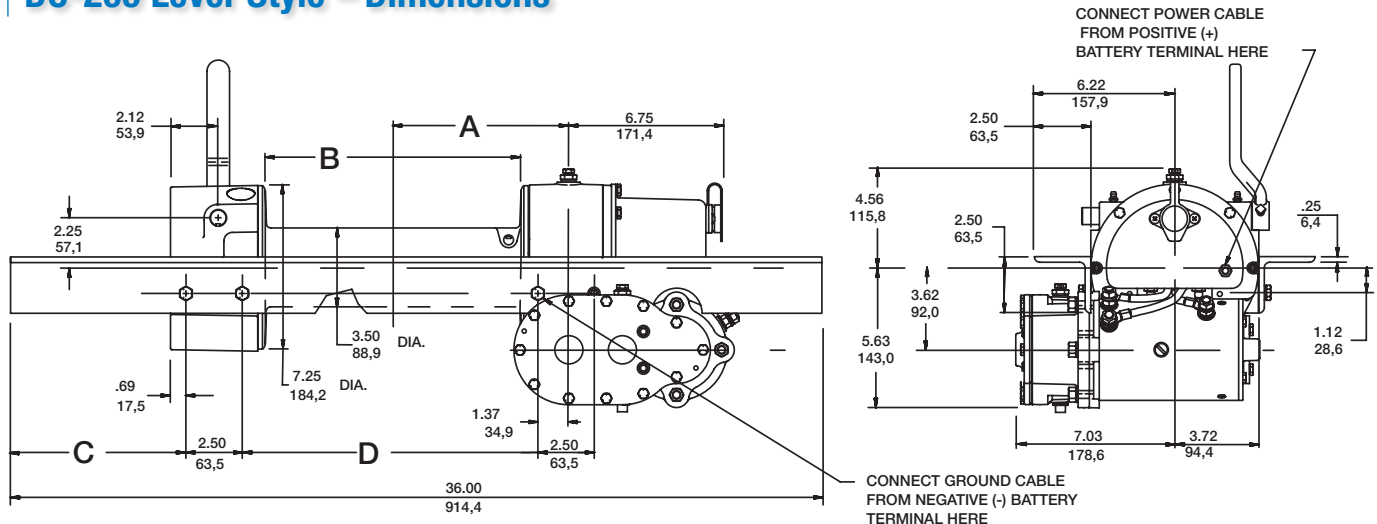

DIMENSIONS SHOWN ARE INCHES OVER MILLIMETERS

WINCH MOUNTING CAPSCREWS MUST MEET OR EXCEED SAE GRADE 5 SPECIFICATION

\*NOTE: THESE HOLE LOCATIONS MUST BE HELD WITHIN .03" (0.8 MM) OF TRUE POSITION. RECOMMENDED MOUNTING HOLE DIAMETER IS .53" (13.5 MM).



# Electric Worm Gear Selection Chart



## Performance Data

### Cable Size & Line Pull

	Volts	Recommended Cable Size (INCH) (MM)	1st Layer		2nd Layer		3rd Layer		4th Layer		5th Layer	
			Line Pull (LBS) (KGS)	Cable Cap. (FT) (M)	Line Pull (LBS) (KGS)	Cable Cap. (FT) (M)	Line Pull (LBS) (KGS)	Cable Cap. (FT) (M)	Line Pull (LBS) (KGS)	Cable Cap. (FT) (M)	Line Pull (LBS) (KGS)	Cable Cap. (FT) (M)
* DC-7 DC-24-7	12 24	1/4 6	3000 1350	10 3	2600 1170	20 6	2200 990	35 10	2000 900	50 15	1800 810	70 21
* DC-7B DC-24-7B	12 24	1/4 6	3000 1350	10 3	2600 1170	20 6	2200 990	35 10	2000 900	50 15	1800 810	70 21
* DCX-7 DC-24-X7	12 24	1/4 6	3000 1350	15 4	2600 1170	40 12	2200 990	65 19	2000 900	95 28	1800 810	125 38
* DCX-7B DC-24X-7B	12 24	1/4 6	3000 1350	15 4	2600 1170	40 12	2200 990	65 19	2000 900	95 28	1800 810	125 38
* DC-200 ** DC-24-246	12 24	3/8 9	8000 3620	25 7	6700 3030	60 18	5700 2580	95 28	5000 2260	140 42		
** DC-246 ** DC-24-246	12 24	3/8 9	8000 3620	25 7	6700 3030	60 18	5700 2580	95 28	5000 2260	140 42		
* DCY-200 ** DCY-24-200	12 24	3/8 9	8000 3620	15 4	6700 3030	30 9	5700 2580	55 16	5000 2260	75 22		
* DCY-246 ** DCY-24-246	12 24	3/8 9	8000 3620	15 4	6700 3030	30 9	5700 2580	55 16	5000 2260	75 22		
** DC-300 ** DC-24-300	12 24	3/8 9	9000 4070	25 7	7500 3390	60 18	6400 2890	95 28	5600 2530	140 42		
** DC-346 ** DC-24-346	12 24	3/8 9	9000 4070	25 7	7500 3390	60 18	6400 2890	95 28	5600 2530	140 42		
** DCY-300 ** DCY-24-300	12 24	3/8 9	9000 4070	15 4	7500 3390	30 9	6400 2890	55 16	5600 2530	75 22		
** DCY-346 ** DCY-24-346	12 24	3/8 9	9000 4070	15 4	7500 3390	30 9	6400 2890	55 16	5600 2530	75 22		

\* Last layer does not conform to SAE Standard J706.

\*\* Winch only conforms to SAE J706. For SAE qualifications of mounting angles, if applicable, consult Ramsey Engineering.

### First Layer Line Speed & Amps

Winch Model	Volts	Recommended Wire Rope Size (INCH) (MM)	First Layer															
			No Load		1000 Load		2000 Load		3000 Load		4000 Load		6000 Load		8000 Load		9000 Load	
			Line Speed (FPM) (MPM)	Amps	Line Speed (FPM) (MPM)	Amps	Line Speed (FPM) (MPM)	Amps	Line Speed (FPM) (MPM)	Amps	Line Speed (FPM) (MPM)	Amps	Line Speed (FPM) (MPM)	Amps	Line Speed (FPM) (MPM)	Amps	Line Speed (FPM) (MPM)	Amps
DC-7 DC-24-7	12 24	1/4 6	17 5.2	80 40	12 3.7	110 60	8 2.4	150 75	6.5 2.0	180 90								
DC-7B DC-24-7B	12 24	1/4 6	17 5.2	80 40	12 3.7	110 60	8 2.4	150 75	6.5 2.0	180 90								
DCX-7 DC-24-X7	12 24	1/4 6	17 5.2	80 40	12 3.7	110 60	8 2.4	150 75	6.5 2.0	180 90								
DCX-7B DC-24X-7B	12 24	1/4 6	17 5.2	80 40	12 3.7	110 60	8 2.4	150 75	6.5 2.0	180 90								
DC-200 DC-24-200	12 24	3/8 9	14 4.3	65 30	10 3.0	90 40	7 2.1	110 50	6 1.8	150 70	5 1.5	180 90	4 1.2	220 110	3 1.1	280 140		
DC-246 DC-24-246	12 24	3/8 9	16.5 5.0	70 35	12 3.6	105 50	8.5 2.5	140 70	7 2.1	170 85	5 1.7	200 100	4 1.3	270 135	3 1.1	330 165		
DCY-200 DCY-24-200	12 24	3/8 9	14 4.3	65 30	10 3.0	90 40	7 2.1	100 50	6 1.8	140 70	5 1.5	180 90	4 1.2	220 110	3 1.1	280 140		
DCY-246 DCY-24-246	12 24	3/8 9	16.5 5.0	70 35	12 3.6	105 50	8.5 2.5	140 70	7 2.1	170 85	5 1.7	200 100	4 1.3	270 135	3 1.1	330 170		
DC-300 DC-24-300	12 24	3/8 9	14 4.3	65 30	10 3.0	90 40	7 2.1	110 50	6 1.8	150 70	5 1.5	180 90	4 1.2	220 110	3.5 1.1	280 140	2.5 .7	310 155
DC-346 DC-24-346	12 24	3/8 9	16.5 5.0	70 35	12 3.6	105 50	8.5 2.5	140 70	7 2.1	170 85	5.5 1.5	200 100	4.5 1.3	270 135	3.5 1.1	330 165	2.5 .7	360 180
DCY-300 DCY-24-300	12 24	3/8 9	14 4.3	65 25	10 3.0	90 40	7 2.1	110 50	6 1.8	150 70	5 1.5	180 90	4 1.2	220 110	3.5 1.1	280 140	2.5 .7	310 155
DCY-346 DCY-24-346	12 24	3/8 9	16.5 5.0	70 35	12 3.6	105 50	8.5 2.5	140 70	7 2.1	170 85	5.5 1.5	200 100	4.5 1.3	270 135	3.5 1.1	340 170	2.5 .7	360 180

Note: Ramsey winches are designed and built for heavy duty intermittent usage only.



# Extended Shaft Winches



Engineered and developed specifically for utility applications, Ramsey Extended Shaft Worm Gear Winches are suitable for both front mount and behind-the-cab installation. Choose from low mount models that will accept a 7" capstan or 20" cable retrieve reel, and can be powered by hydraulic or mechanical drive. All models are available with single or double end extension shafts.

All models feature side-opening gear boxes, adjustable oil-cooled automatic safety brakes, free-spooling drum clutches (blocked clutches optional) and one-piece, heat-treated alloy steel worm gears supported by angular contact ball bearings which never need adjustment.

For more information, see Extended Gear Winch Brochure.

## Model HG400/H600/H700/H800 EB/EEB Series Dimensions

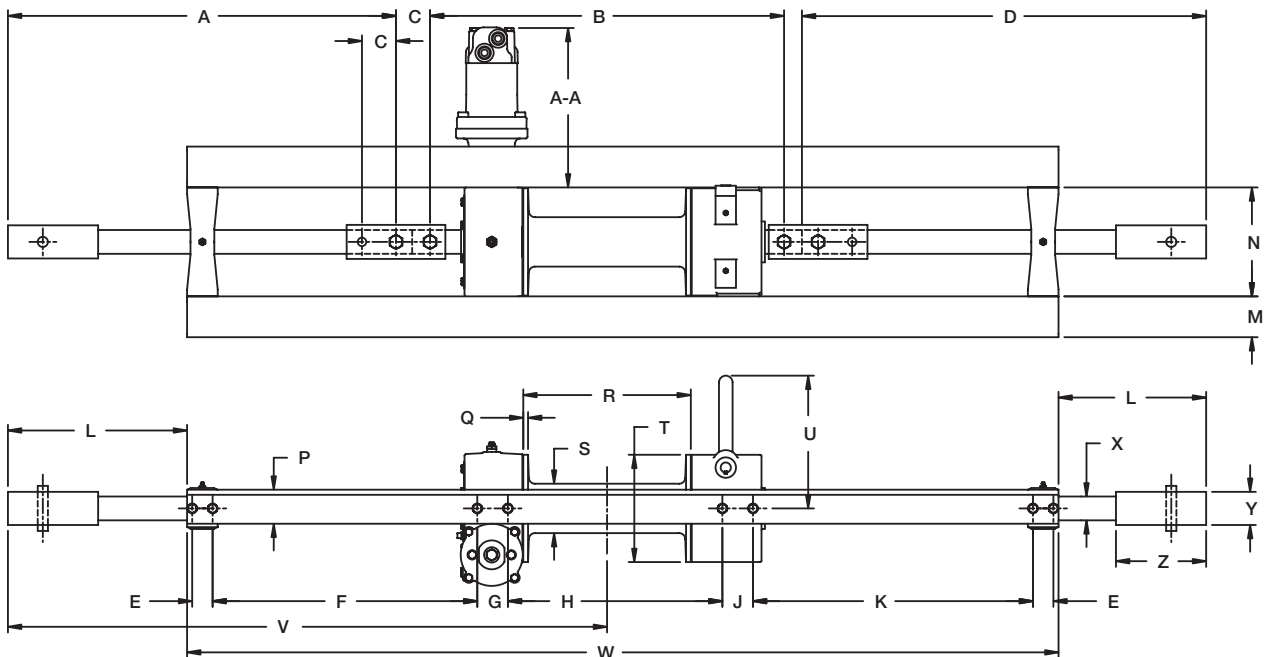

## Model HG400/H600/H700/H800 EB/EEB Series – Dimensions

Model	A Inches MM	B Inches MM	C Inches MM	D Inches MM	E Inches MM	F Inches MM	G Inches MM	H Inches MM	J Inches MM	K Inches MM	L Inches MM	M Inches MM	N Inches MM
<b>HG400 EB/EEB</b>	28.50 723.9	26.00 660.4	2.50 63.5	29.69 754.1	1.50 38.1	20.56 522.2	2.25 57.1	15.75 400.0	2.25 57.1	19.44 493.7	12.00 304.8	3.00 76.2	8.00 203.2
<b>H600 EB/EEB</b>	28.50 723.9	26.00 660.4	2.50 63.5	29.69 754.1	1.50 38.1	20.12 511.1	2.50 63.5	14.44 366.7	2.50 63.5	20.12 493.7	12.00 304.8	2.50 63.5	9.75 247.6
<b>H700 EB/EEB</b>	28.31 719.1	26.37 669.8	2.50 63.5	29.50 749.3	2.50 63.5	18.56 471.4	2.50 63.5	15.37 390.4	2.50 63.5	18.56 471.5	12.00 304.8	3.00 76.2	11.00 25.4
<b>H800 EB/EEB</b>	25.37 644.4	32.25 819.1	2.50 63.5	26.56 674.7	2.50 63.5	16.37 415.8	2.50 63.5	19.37 492.0	2.50 63.5	17.00 431.8	12.00 304.8	3.00 76.2	12.37 314.4
	<b>P</b>	<b>Q</b>	<b>R</b>	<b>S(DIA)</b>	<b>T(DIA)</b>	<b>U</b>	<b>V</b>	<b>W</b>	<b>X(DIA)</b>	<b>Y(DIA)</b>	<b>Z</b>	<b>A-A</b>	
<b>HG400 EB/EEB</b>	2.50 63.5	.31 7.9	12.37 314.2	3.62 92.0	7.87 199.9	9.75 247.6	44.00 1117.6	64.00 1625.6	1.75 44.4	2.44 61.9	6.62 168.2	11.37 288.8	
<b>H600 EB/EEB</b>	3.00 76.2	.31 7.9	12.37 314.2	4.00 101.6	9.50 241.3	10.75 373.0	44.00 1117.6	64.00 1625.6	1.75 44.4	2.44 61.9	6.62 168.2	11.37 288.8	
<b>H700 EB/EEB</b>	3.00 76.2	.50 12.7	12.00 304.8	4.50 114.3	10.62 269.7	11.87 301.5	44.00 1117.6	64.00 1625.6	2.25 57.1	2.44 61.9	6.62 168.2	12.81 325.4	
<b>H800 EB/EEB</b>	3.50 88.9	.50 12.7	16.00 406.4	5.50 139.7	12.12 307.8	10.06 255.5	44.00 1117.6	64.00 1625.6	2.50 63.5	2.44 61.9	6.62 168.2	16.12 409.5	

## Extended Shaft Selection Chart

### Performance Data

Conforms to SAE Standard J706 except as noted

Winch Model	Recommended Cable Size INCHES MM	Worm RPM	Worm Gear Ratio	1st Layer			2nd Layer			3rd layer			4th layer			5th Layer		
				Rated Line Pull LBS. KGS.	Cable Cap. Ft. M	Line Speed (FPM) (MPM)	Rated Line Pull LBS. KGS.	Cable Cap. Ft. M	Line Speed (FPM) (MPM)	Rated Line Pull LBS. KGS.	Cable Cap. Ft. M	Line Speed (FPM) (MPM)	Rated Line Pull LBS. KGS.	Cable Cap. Ft. M	Line Speed (FPM) (MPM)	Rated Line Pull LBS. KGS.	Cable Cap. Ft. M	Line Speed (FPM) (MPM)
<b>G400/HG400 EB/EEB</b>	7/16 11	840	29:1	10,000 4,530	25 7	30 9	8,200 3,710	55 16	37 11	6,900 3,120	90 27	44 13	6,000 2,710	130 39	50.0 15.0			
* <b>600/H600 EB/EEB</b>	1/2 13	870	40:1	12,000 5,430	20 6	25.0 7.6	9,800 4,430	55 16	31.0 9.4	8,300 3,750	90 27	37.0 11.2	7,200 3,260	130 39	42.0 12.7	6,300 2,850	180 54	48.0 14.5
* <b>700/H700 EB/EEB</b>	9/16 14	713	35:1	15,000 6,790	20 6	27.0 8.2	12,300 5,570	50 15	33.0 10.0	10,500 4,750	85 25	38.0 11.5	9,100 4,120	125 38	44.0 13.3	8,100 3,660	170 51	50.0 15.2
* <b>800/H800 EB/EEB</b>	5/8 16	460	40:1	20,000 9,060	35 10	18.0 5.4	16,600 7,510	75 22	22.0 6.6	14,200 6,430	125 38	26.0 7.9	12,400 5,610	180 54	29.0 8.8	11,000 4,980	240 72	33.0 10.0

\* Last layer does not conform to SAE Standard J706

## Extended Shaft Ratings

Winch Model			
Overhang Dimension "L"	400 600	700	800
Load Cap. With 7 1/4" Max. Dia. Capstan			
12"	1600 lbs.	3500 lbs.	4700 lbs.
14 1/2"	1500 lbs.	3200 lbs.	4300 lbs.
Load Cap. With 20" Dia. (24" Mean Dia.) Cable Retrieve Reel			
Any standard overhang shown above	1000 lbs.	1800 lbs.	1900 lbs.



# Worm Gear Speed Reducers



Thousands of Ramsey Worm Gear Speed Reducers have proven their value in a wide range of applications, from pipelining equipment to conveyor belts. For more information, see Speed Reducers and Transmissions Brochure.

## Model S-200 – Dimensions

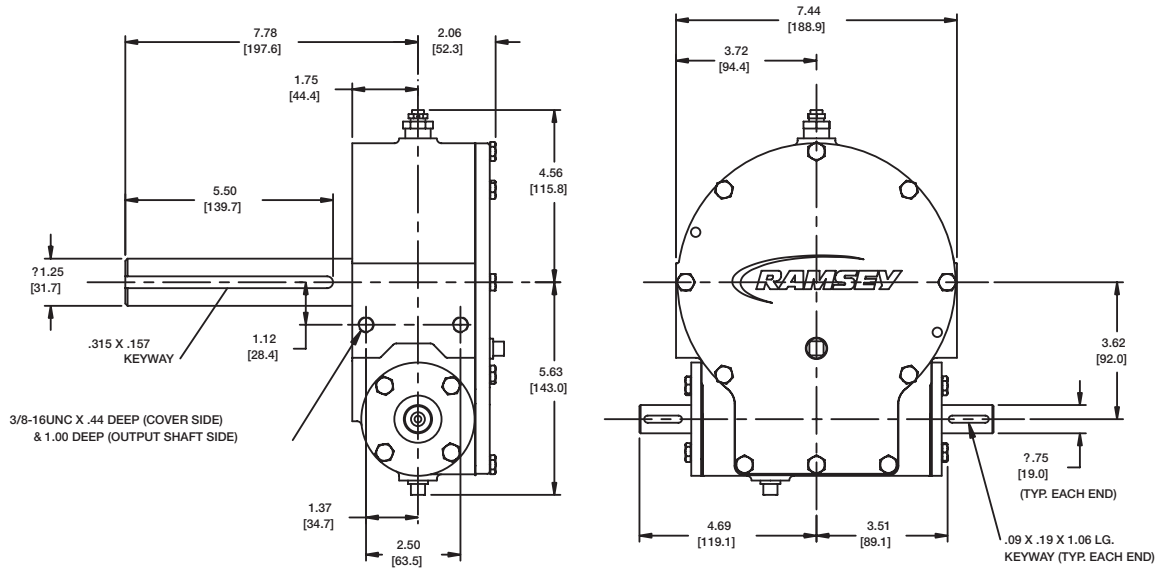

## Model S-800 – Dimensions

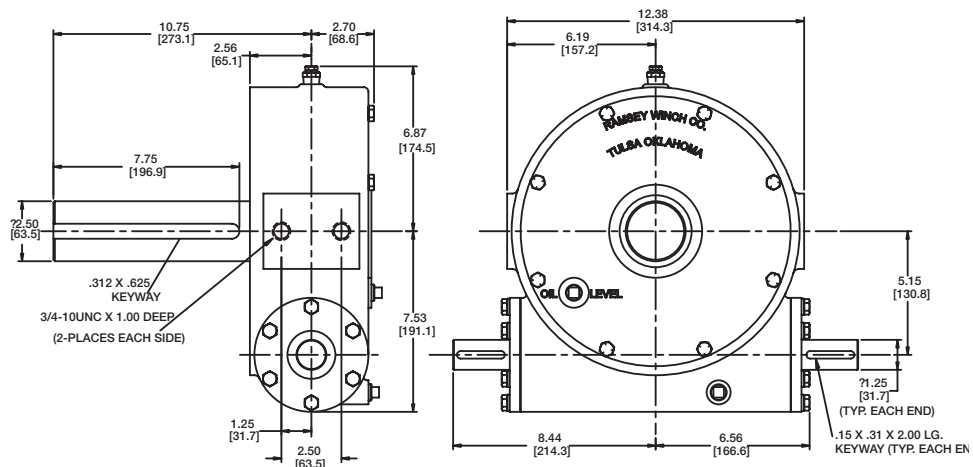

## How to Select and Order Your Speed Reducer

1. Torque – Check the performance data tables and choose the model or models having rated output torque equal or greater than the torque required for the job.
2. Speed – Note the maximum input RPM. Do not exceed this RPM.

To order, specify model number, dimensions and specifications of output shaft (if not standard); state whether output shaft is to rotate in same direction or opposite direction of input shaft rotation; whether output shaft should be extended to right or left (when facing input) and whether automatic worm brake is desired as an extra.

Note: Specifications and Performance data are based on **NO** overhung load.

## Worm Gear Speed Reducer Selection Chart

Model	Rated Output Torque In./Lbs.	Rated Input Torque In./Lbs.	Max Input RPM	Gear Reduction
<b>S7</b>	4,800	400	1,200	38:1
<b>S200</b>	15,500	800	1,000	60:1
<b>S246</b>	15,500	1,000	1,000	46:1
<b>SD200</b>	15,500	1,050	1,000	30:1
<b>S400</b>	26,600	2,650	900	29:1
<b>S600</b>	36,000	2,600	900	40:1
<b>S700</b>	53,000	4,350	700	35:1
<b>S800</b>	78,700	5,650	500	40:1
<b>S930</b>	99,300	7,100	400	41:1

\*Data is based on no overhung load. Outboard end of shaft must be supported.



# Options For Ramsey Winches: Worm Gear and Planetary

**Model-1 Level Winder For H-200, H-300, HDG-350 winches and others with 11 5/16" between drum flanges Kit #256048**

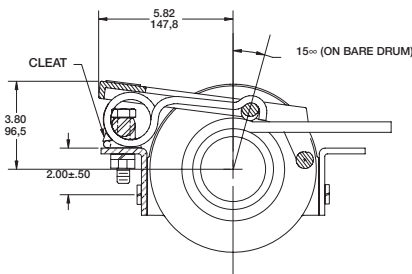

**Model-2 Level Winder for HY-200, HY-300, HDGY-350, HD-P 8000Y, HD-P 10000Y winches or others with 6 5/16"– 6 1/2" drums Kit #256052**

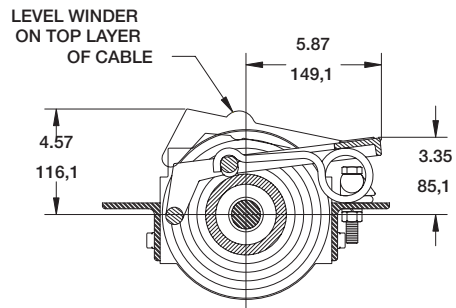

**Model-3 Level Winder for HD-P 8000S and HD-P 10000S (9 3/4" DRUM) KIT #256078**

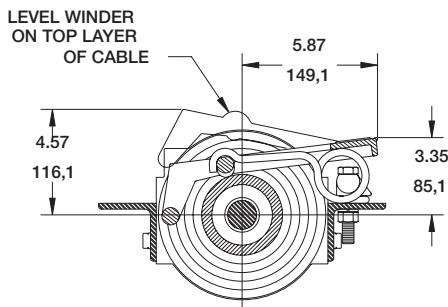

**Model-4 Level Winder For H-400 winches with 11 5/8" drum Kit #256076**

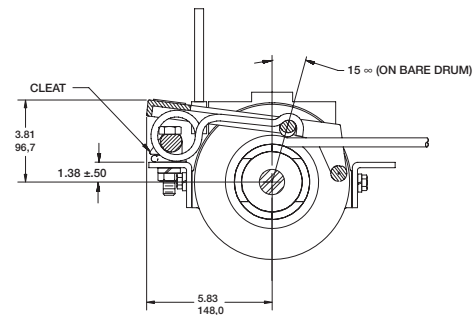

**Model-5 Level Winder for RPH 12000 (9 3/4" Drum) Kit #256082**

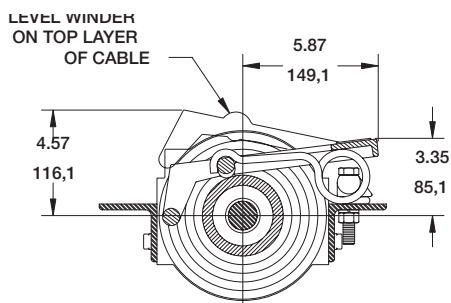

**Model H-600 Spring Tensioner Kit #256096**

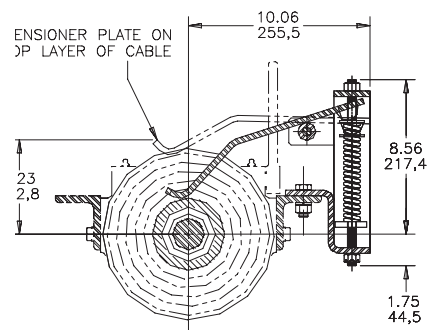

Spring applied cable tensioners (available as shown)



### Model H-700 Spring Tensioner Kit #256109

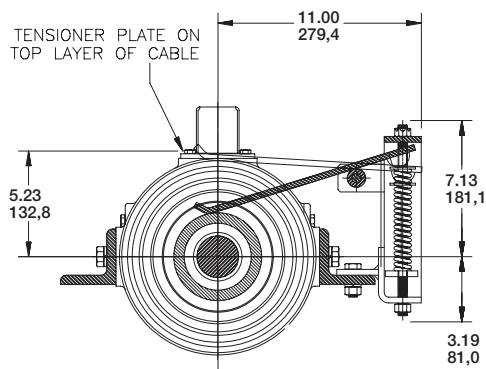

### Model H-800 Spring Tensioner Kit #256107

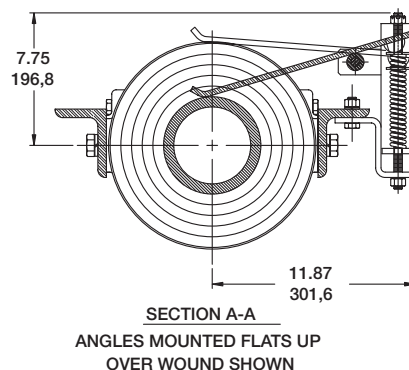

### Air Cable Tensioner For RPH 20000 and RPH 25000 (15" DRUM) KIT #256086 Overwound and KIT #256087 Underwound

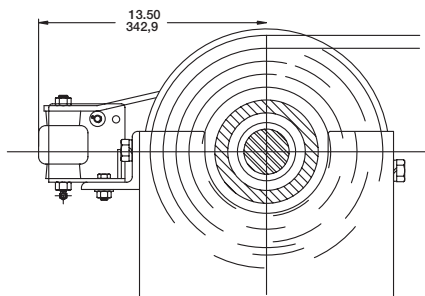

### Air Cable Tensioner For RPH 30000 winches and RPH 35,000 winches KIT #256088 Overwound and KIT #256089 Underwound

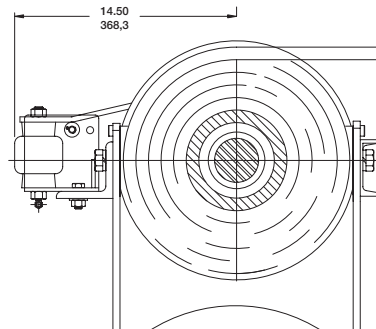

### Air Cable Tensioner For RPH 45000 and RPH 50000 (14 1/2" DRUM) KIT #256090 Overwound and KIT #256091 Underwound

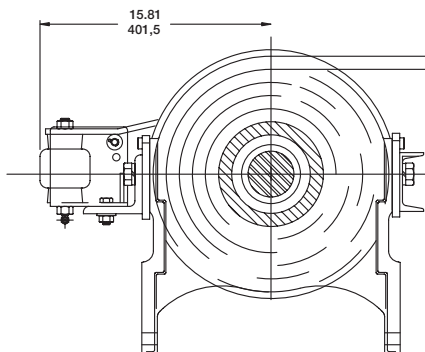

### Roller Guide for Model-1 Level Winder #256049

### Roller Guide for Model-2 Level Winder #256053

### Roller Guide for Model-3 Level Winder #256079

### Pressure Regulator Kit (Required for all air tensioners) #256092



P.O. Box 581510 • Tulsa, OK 74158-1510 U.S.A • Phone: (918) 438-2760 • Fax: (918) 438-6688

For more information visit:

**ramsey.com**

