

# FRM2L

## Rear suspension package Ensemble pour suspension arrière Ensemble para suspensión de trasero

### INSTALLATION INSTRUCTIONS

- With vehicle unloaded measure 5" from the Timbren frame bracket to U-bolt pad.
- When positioning frame bracket ensure that the Aeon spring rests over center of U-bolt pad.
- Drill holes for frame bracket providing for at least four ½" Gr.8 bolts through the bracket & frame. (Bolt frame bracket to frame using existing holes where possible)
- Assemble Aeon spring to bracket as shown in adjacent diagram.
- Weld Timbren lower assembly to U-bolt pad.

#### NOTES

Holes in frame bracket must be within the gusset area.

#### SAFETY CAUTIONS

Ensure sufficient clearance between frame bracket & tire.

Do not exceed vehicle manufacturer's recommended axle weight rating. Check for AEON® interference with vehicle components - Under load AEON® will "expand" in diameter.

### INSTRUCTIONS DE MONTAGE

- Mesurer 5 po quand le vehicle est vide, à partir du support du cadre de Timbren jusqu'au support des boulons d'attache en U.
- S'assurer, au moment de positionner le support du cadre, que le ressort Aeon demeure au centre du support des boulons d'attache en U.
- Perçer des trous pour le support du cadre pouvant recevoir au moins quatre boulons de ½ po Gr.8 à travers le support et le cadre. (Fixer à l'aide de boulons le support du cadre au cadre en utilisant les trous existants là où c'est possible.)
- Assembler le ressort Aeon au support comme il est indiqué dans le schéma adjacent.
- Souder l'assemblage inférieur Timbren au support des boulons d'attache en U.

#### REMARQUES

Faire les trous dans le support du cadre à l'intérieur de la zone de la plaque de jonction.

#### MESURES DE SÉCURITÉ

Assurer un dégagement suffisant entre le support du cadre et les pneus.

Ne pas dépasser le poids nominal sur l'essieu recommandé par le fabricant du véhicule. Vérifier que le ressort AEON® n'a pas d'incidence sur d'autres pièces du véhicule - Le ressort AEON® augmentera son diamètre avec la charge.

### INSTRUCCIONES DE INSTALACIÓN

- Medir 5 Po cuando el vehicle es vacío, a partir del apoyo del marco de Timbren hasta el apoyo de los pernos de lazo en U.
- Al colocar en posición la abrazadera del chasis, asegúrese de que el resorte Aeon descansa sobre el centro del apoyo de los pernos delazo en U.
- Perfore los orificios para la abrazadera del chasis previendo al menos para cuatro pernos de ½" Gr.8 a través de la abrazadera y el chasis. (Atornille la abrazadera del chasis al chasis utilizando los orificios existentes donde sea posible)
- Ensamble el resorte Aeon a la abrazadera como se muestra en el diagrama adyacente.
- Soldar la unidad inferior Timbren con el apoyo de los pernos de lazo en U.

#### NOTAS

Los orificios en la abrazadera del chasis deben estar en el área de la placa de refuerzo.

#### PRECAUCIONES DE SEGURIDAD

Deje suficiente espacio libre entre la abrazadera del chasis y la llanta.

No exceda la carga nominal en el eje recomendada por el fabricante del vehículo. Compruebe que no haya interferencia entre el resorte AEON® y los otros componentes del vehículo. Bajo carga, el resorte AEON® se ampliará en diámetro.

Ref. = Reference = No. de référence = Núm. de referencia  
Part = Part #. = No. de pièce = Núm. de pieza  
Qty. = Quantity = Quantité = Cantidad

| Ref | Part         | Qty |
|-----|--------------|-----|
| 1   | F11102-150   | 4   |
| 2   | F40052-020   | 4   |
| 3   | K10135-005   | 2   |
| 4   | A00200-65V00 | 2   |
| 5   | K51391-005   | 2   |

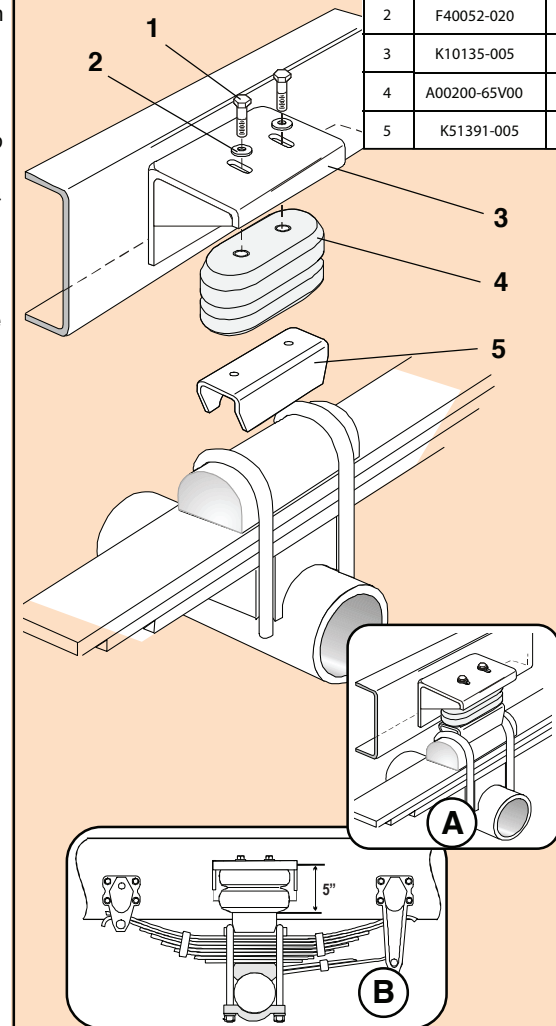

FRM2L



## FRM2L

TIMBREN INDUSTRIES INC.

[www.timbren.com](http://www.timbren.com)

| PART NUMBER       | DESCRIPTION                        | QTY      | LOCATION   |
|-------------------|------------------------------------|----------|------------|
| <b>F40052-020</b> | WASHER FLAT USS 1/2 x 1-3/8 GR 2 Z | <b>4</b> | <b>G1D</b> |
| <b>F11102-150</b> | HCS 1/2 x 1-1/2 UNF GR 5 Z         | <b>4</b> | <b>G1D</b> |

|                     |                      |          |             |
|---------------------|----------------------|----------|-------------|
| <b>A00200-65V00</b> | Hollow Rubber Spring | <b>2</b> | <b>C17A</b> |
|---------------------|----------------------|----------|-------------|

|                   |                                  |          |            |
|-------------------|----------------------------------|----------|------------|
| <b>K10135-005</b> | URMDB / URMDH WELDMENT (PAINTED) | <b>2</b> | <b>D7B</b> |
| <b>K51391-005</b> | CHANNEL - PAINTED                | <b>2</b> | <b>D9A</b> |

|                   |                              |          |            |
|-------------------|------------------------------|----------|------------|
| <b>B90223</b>     | 10-3/4 x 9-1/2 x 7 DW Carton | <b>1</b> | <b>A1A</b> |
| <b>B10100</b>     | NEWSPRINT 18" ROLL           | <b>1</b> |            |
| <b>B00029-010</b> | BARCODE LABEL FOR KIT        | <b>1</b> |            |

Issued: 8/11/2016

### Clearance Instructions:

Rear SES Kits for Pick-Ups and Vans should have a 1/2" to 1-1/2" gap between the rubber spring and contact point when empty.

A partial load, or vehicle accessories will reduce or eliminate the gap.

Front SES kits are usually in full contact.

Medium and Heavy-Duty Trucks, Trailers and Motorhomes will be in constant contact, and have no gap.

### Lifetime Warranty:

Timbren SES Kits are warranted against defects in material and workmanship, under normal use and service, for the life of the vehicle on which the kit was originally installed. The warranty is not transferable and proof of purchase is required. The warranty is limited to the replacement of the failed part.

TIMBREN will not be responsible for any labour or freight charges involved in the replacement of any product. TIMBREN shall be entitled to make its own inspection to determine the validity of the claim. TIMBREN shall not be liable nor warranty the product in the event of alteration, misuse, overload, negligence or damage caused by others.

If ride or performance of our product is unsatisfactory in any way, please call: 1-800-263-3113 or email [sales@timbren.com](mailto:sales@timbren.com)