

HRTT01HD

HENDRICKSON

Rear suspension package Ensemble pour suspension arrière Ensemble para suspensión de trasero

INSTALLATION INSTRUCTIONS

- With vehicle unloaded, measure 6-3/4" from top of U-bolt pad (or Timbren bottom plate) to bottom of Timbren frame bracket (see Diagram A)
- Drill holes for Timbren bracket providing for at least four 1/2" Gr.8 bolts through the bracket & frame.
- Assemble Aeon rubber spring and Timbren frame bracket.
- Remove rear rebound bolt. Using a pillow jack between leaf spring & frame, jack the leaf spring away from the spring hanger (about 3"). Be sure to block the two apart (see diagram B)
- Bolt the Timbren assembly to the frame making sure that the bottom plate is in place. Let the frame come down to rest on bottom plate.
- Reinstall the rebound bolt.
- See page 2 for installation instructions of bottom plate #6.

SAFETY CAUTIONS

Ensure sufficient clearance between frame bracket & tire.
Always refer to and follow the vehicle manufacturer's guidelines when welding or drilling during installation of this kit.

Do not exceed vehicle manufacturer's recommended axle weight rating. Check for AEON® interference with vehicle components - Under load AEON® will "expand" in diameter.

INSTRUCTIONS DE MONTAGE

- Calculer 6-3/4 po entre la partie supérieure du coussin du boulon en U (ou la partie inférieure de la plaque Timbren) et la partie inférieure du support du cadre Timbren pour les véhicules à vide (voir le schéma A)
- Perçer des trous pour le support Timbren pouvant recevoir au moins quatre boulons de 1/2 po Gr.8 à travers le support et le cadre.
- Assembler le ressort en caoutchouc Aeon et le support du cadre Timbren.
- Retirer le boulon de rebondissement arrière. Insérer un vérin souple entre le ressort à lames et le cadre de manière à soulever le ressort à lames de la patte de fixation de ressort (environ 3 po). S'assurer de bloquer les deux éléments séparément (voir le schéma B)
- Fixer à l'aide de boulons l'assemblage Timbren au cadre en vous assurant que la plaque inférieure est en place. Laisser le cadre reposer sur la plaque inférieure.
- Remettre en place le boulon de rebondissement.
- Se référer à la page 2 pour les instructions d'installation de la plaque inférieure no 6.

MESURES DE SÉCURITÉ

Assurer un dégagement suffisant entre le support du cadre et les pneus.
Se référer aux directives du fabricant et les suivre en tout temps lors du soudage ou du perçage en ce qui concerne l'installation du présent ensemble.

Ne pas dépasser le poids nominal sur l'essieu recommandé par le fabricant du véhicule. Vérifier que le ressort AEON® n'a pas d'incidence sur d'autres pièces du véhicule - Le ressort AEON® augmentera son diamètre avec la charge.

INSTRUCCIONES DE INSTALACIÓN

- Con el vehículo descargado, mida 6-3/4" desde la parte superior del cojín amortiguador del perno "U" (o la placa inferior Timbren) hasta la parte inferior de la abrazadera del chasis Timbren (vea Diagrama A)
- Perfore los orificios para la abrazadera Timbren previendo al menos para cuatro pernos de 1/2" Gr.8 a través de la abrazadera y el chasis.
- Ensamble el resorte de caucho Aeon y la abrazadera del chasis Timbren.
- Retire el perno de rebote posterior. Con un gato de expansión entre el resorte de ballesta y el chasis, levante el resorte de ballesta de la suspensión de resorte (cerca de 3"). Asegúrese de bloquear los dos para que se mantengan separados (vea diagram B)
- Atornille la unidad Timbren al chasis asegurándose de que la placa inferior esté en su sitio. Deje que baje el chasis para que descance en la placa inferior.
- Reinstale el perno de rebote.
- Vea la página 2 para las instrucciones de instalación de la placa inferior #6.

PRECAUCIONES DE SEGURIDAD

Deje suficiente espacio libre entre la abrazadera del chasis y la llanta.
Siempre consulte y siga las instrucciones del fabricante del vehículo al soldar o perforar durante la instalación de este kit.

No exceda la carga nominal en el eje recomendada por el fabricante del vehículo. Compruebe que no haya interferencia entre el resorte AEON® y los otros componentes del vehículo. Bajo carga, el resorte AEON® se ampliará en diámetro.

Ref. = Reference = No. de référence = Núm. de referencia
Part = Part #. = No. de pièce = Núm. de pieza
Qty. = Quantity = Quantité = Cantidad

Ref	Part	Qty
1	K10001-005	2
2	F31005-150	4
3	F40053-020	8
4	A00260-75D60	2
5	F11106-150	4
6	K51079-005	2
7	K53016-005	8
8	K10017-003	2
9	F11104-150	4

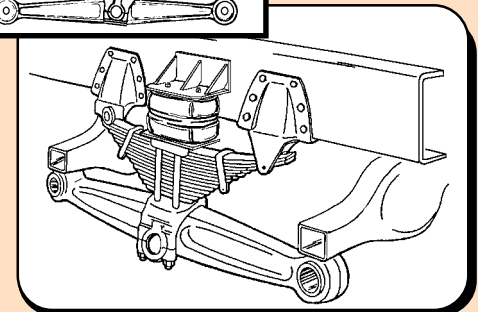
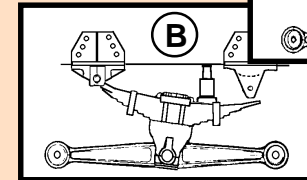
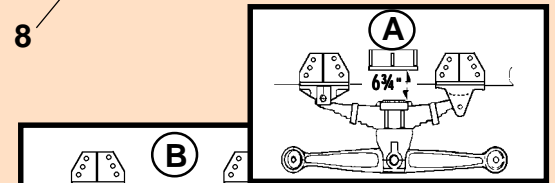
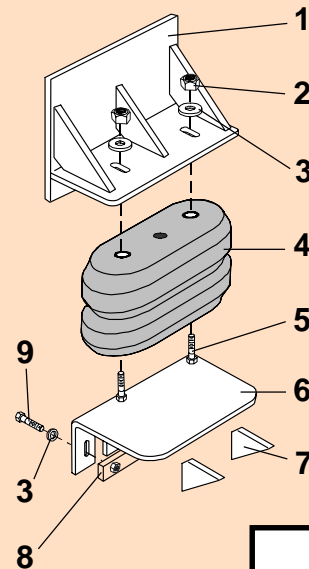

HRTT01HD

TIMBREN

HRTT01HD

TIMBREN INDUSTRIES INC.

www.timbren.com

PART NUMBER	DESCRIPTION	QTY	LOCATION
F31005-150	NYLOCK LOCKNUT 1/2 UNF GR 5 Z	4	G1D
F40053-020	WASHER FLAT 1/2 x 1-1/2 GR 2 Z	8	G4A
F11104-150	HCS 1/2 x 2 UNF GR 5 Z	4	G1D
F11106-150	HCS 1/2 x 2-1/2 UNF GR 5 Z	4	G1D

A00260-75D60	Hollow Rubber Spring	2	C17E
--------------	----------------------	---	------

K10001-005	HRTT01 / PTA001 WELDMENT PAINTED	2	D2A
K10017-003	HRTT01 WELDMENT PAINTED	2	D6B
K51079-005	FORMED PLATE 3/8 x 12 x 14-3/4 PAINTED	2	D6B
K53016-005	GUSSET 3/8 x 1-1/2 x 3 PAINTED	8	D6B

B90213	#200 DOUBLE WALL BOX - 13 x 13 x 7"	2	A4A
B10100	NEWSPRINT 18" ROLL	1	
B00029-010	BARCODE LABEL FOR KIT	2	
	1 of 2 & 2 of 2 LABELS	1 ea.	

Issued: 5/12/2011

Clearance Instructions:

Rear SES Kits for Pick-Ups and Vans should have a 1/2" to 1-1/2" gap between the rubber spring and contact point when empty.

A partial load, or vehicle accessories will reduce or eliminate the gap.

Front SES kits are usually in full contact.

Medium and Heavy-Duty Trucks, Trailers and Motorhomes will be in constant contact, and have no gap.

Lifetime Warranty:

Timbren SES Kits are warranted against defects in material and workmanship, under normal use and service, for the life of the vehicle on which the kit was originally installed. The warranty is not transferable and proof of purchase is required. The warranty is limited to the replacement of the failed part.

TIMBREN will not be responsible for any labour or freight charges involved in the replacement of any product. TIMBREN shall be entitled to make its own inspection to determine the validity of the claim. TIMBREN shall not be liable nor warranty the product in the event of alteration, misuse, overload, negligence or damage caused by others.

If ride or performance of our product is unsatisfactory in any way, please call: 1-800-263-3113 or email sales@timbren.com

ASSEMBLY NOTES:

ALL COMPONENTS ARE DIVIDED IN HALF AND PACKAGED INTO TWO IDENTICAL PACKAGES.

APPLY "1 of 2" and "2 of 2" LABELS TO CARTONS.