





Installation Guide

Axle Slide Mount Tunnel Version

Below is a list of parts you will need to install an Axle Slide Mount Tunnel Version.
Mounting hardware is NOT included with product.

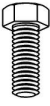
Required Mounting Hardware List:

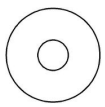
-  (4) 5/16" Bolts (Grade 5 or better)
-  (4) 5/16" Nuts (Grade 5 or better)
-  (4) 5/16" Fender Washers
-  (4) 5/16" Washers

MOUNTING INSTRUCTIONS



READ ALL SAFETY WARNINGS & INSTRUCTIONS CAREFULLY
BEFORE MOUNTING OR OPERATING YOUR AXLE SLIDE MOUNT



Parts List:

Item #	Qty	Description	Part #
1	(1)	Axle Slide Mount Tunnel	ITD1141

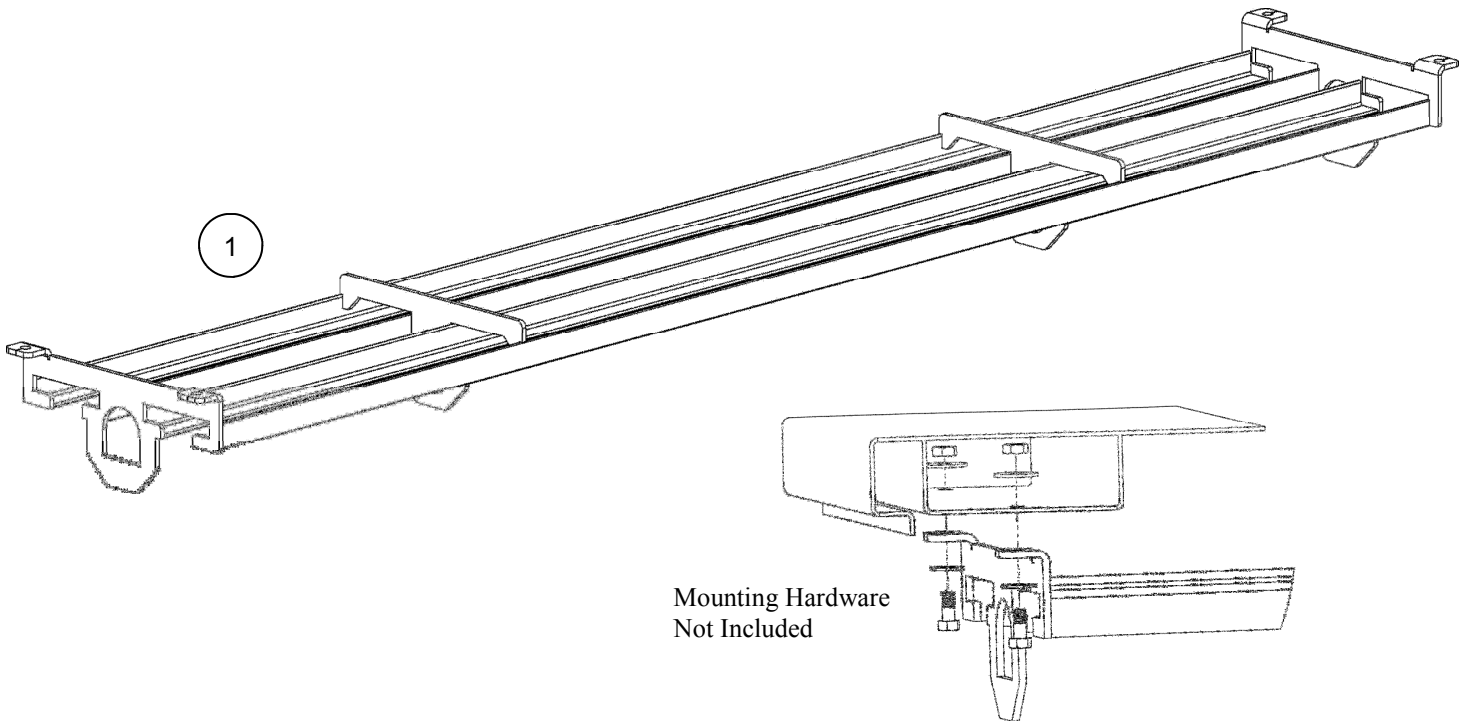

For missing or damaged parts, please call 1-888-993-4824



Caution



Due to variances in bed designs, ITD cannot provide explicit mounting requirements for every box. These are only guidelines, final installation requirements are left to the discretion of the installer. ITD will NOT warrantee any damage to tool boxes resulting from inadequate mounting.

Step 1

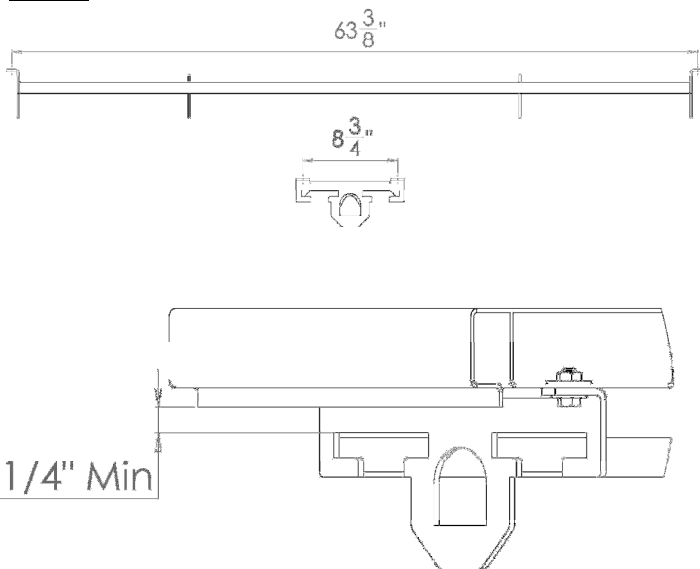

Step 1

Place Axle Slide mount in desired location. Verify axles and bar will slide easily without obstruction.

Note:

Most applications will need additional mounts to lower the product below the lip of the door.

Step 2

Mark 4 hole positions and drill.

Note:

Before drilling holes, verify there are no electrical wires in the way.

Step 3

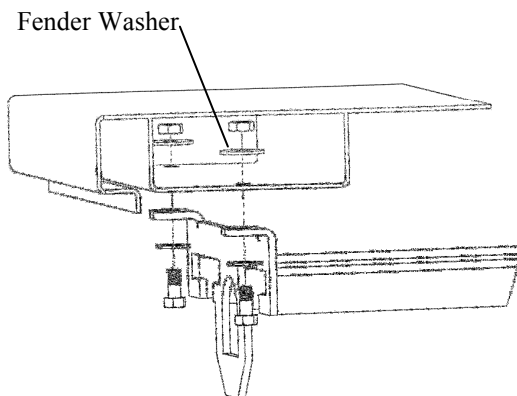

Step 3

Utilize 4 - 5/16" bolts with fender washers to help distribute load.

Before First Use Checklist:

- All nuts and bolts are tight



Warning



Inspect and retighten after first 10 uses