

REV.	DESCRIPTION	DATE	APPROVED
------	-------------	------	----------

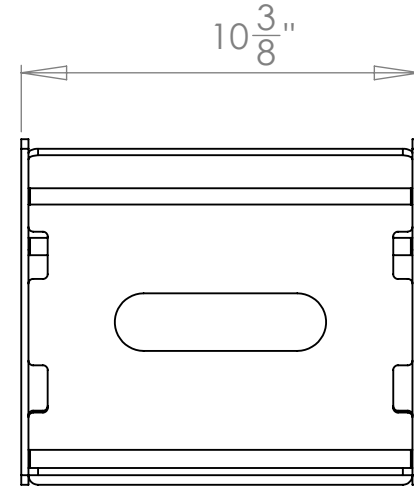
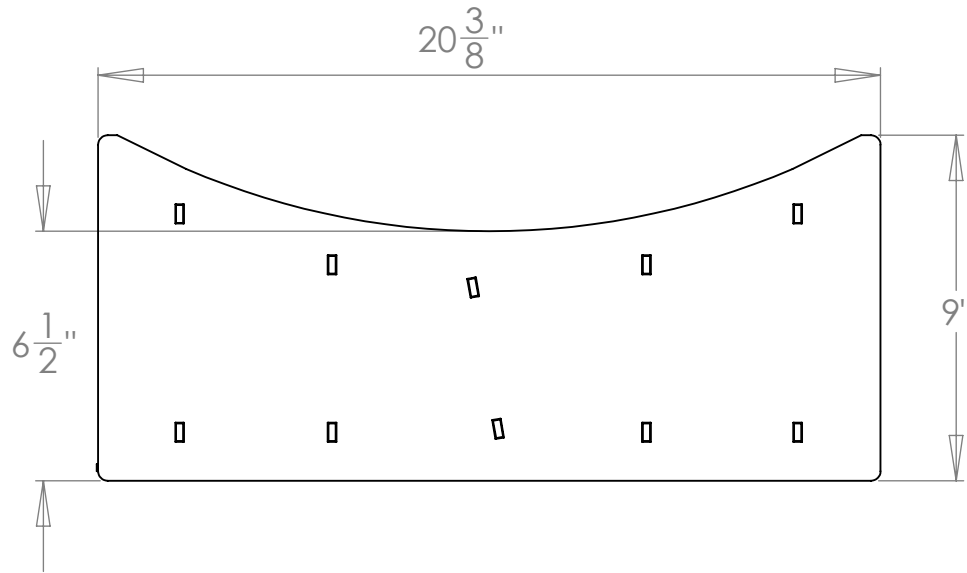
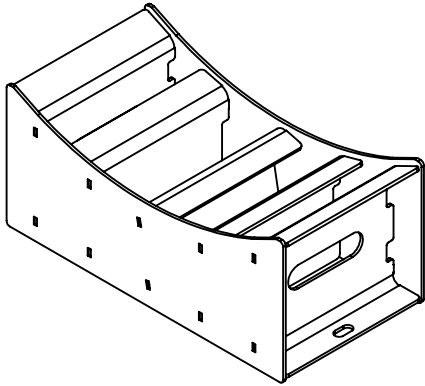

3/16" 5052 Aluminum Sheet

10,000 lbs. Rating

DRAWN BY: KBH DRAWN DATE: 7/30/2012
 UNLESS OTHERWISE SPECIFIED:
 DIMENSIONS ARE IN INCHES
 TOLERANCES:
 FRACTIONAL ± 1/16"
 ANGULAR: MACH ± 0.25° BEND ± 1.5°
 TWO PLACE DECIMAL ± 0.020"
 THREE PLACE DECIMAL ± 0.005"
 MATERIAL: See BOM
 DO NOT SCALE DRAWING

Inventive LLC
 In The Ditch Towing Products
 PART NAME
Aluminum Tire Stand
 SIZE PART NO.
A ITD1132-01
 SHEET SCALE 1:10 SHEET 1 of 1