

MBRSP35A

MERCEDES / CHRYSLER /
FREIGHTLINER MOTOR HOME

Rear suspension package
Ensemble pour suspension arrière
Ensemble para suspensión de trasero

INSTALLATION INSTRUCTIONS

- Raise vehicle allowing the axle to hang freely.
- Remove existing bump stop using a screwdriver or putty knife to pry the bump stop out of the bracket.
- Mount preassembled Aeon® rubber spring and bracket as shown in the adjacent diagram.
- Lower vehicle.

NOTES

Check that brake line or brake cable locations do not interfere with Aeon spring.

INSTRUCTIONS DE MONTAGE

- Soulever le véhicule de sorte que l'essieu soit dégagé.
- Enlever la butée d'essieu en utilisant soit un tournevis ou soit un couteau à mastic, pour forcer l'extraction de la butée du support.
- Installer le ressort en caoutchouc Aeon® prémonté sur le support tel qu'indiqué sur le schéma adjacent.
- Redescendre le véhicule.

REMARQUES

Vérifier que les emplacements de la conduite de frein et du câble de frein ne nuisent pas au ressort Aeon.

INSTRUCCIONES DE INSTALACIÓN

- Levante el vehículo dejando que los ejes cuelguen libremente.
- Quitar el tope del eje utilizando una espátula o un destornillador para remover este tope del soporte.
- Instalar el resorte de goma Aeon® pre ensamblado al soporte tal qu'indicado sobre el esquema adyacente.
- Baje el vehículo.

NOTAS

Verifique que la ubicación de la tubería de freno o del cable del freno no interfiera con el resorte Aeon.

Do not exceed vehicle manufacturer's recommended axle weight rating. Check for AEON® interference with vehicle components - Under load AEON® will "expand" in diameter.

Ne pas dépasser le poids nominal sur l'essieu recommandé par le fabricant du véhicule. Vérifier que le ressort AEON® n'a pas d'incidence sur d'autres pièces du véhicule - Le ressort AEON® augmentera son diamètre avec la charge.

No exceda la carga nominal en el eje recomendada por el fabricante del vehículo. Compruebe que no haya interferencia entre el resorte AEON® y los otros componentes del vehículo. Bajo carga, el resorte AEON® se ampliará en diámetro.

Ref. = Reference = No. de référence = Núm. de referencia
Part = Part #. = No. de pièce = Núm. de pieza
Qty. = Quantity = Quantité = Cantidad

KIT PRE-ASSEMBLED

Ref	Part	Qty
1	F13538-753	4
2	F40031-020	4
3	A1755B	4
4	A25778A-75000	2
5	A25683-90P00	2
6	A00100-55AG00	2

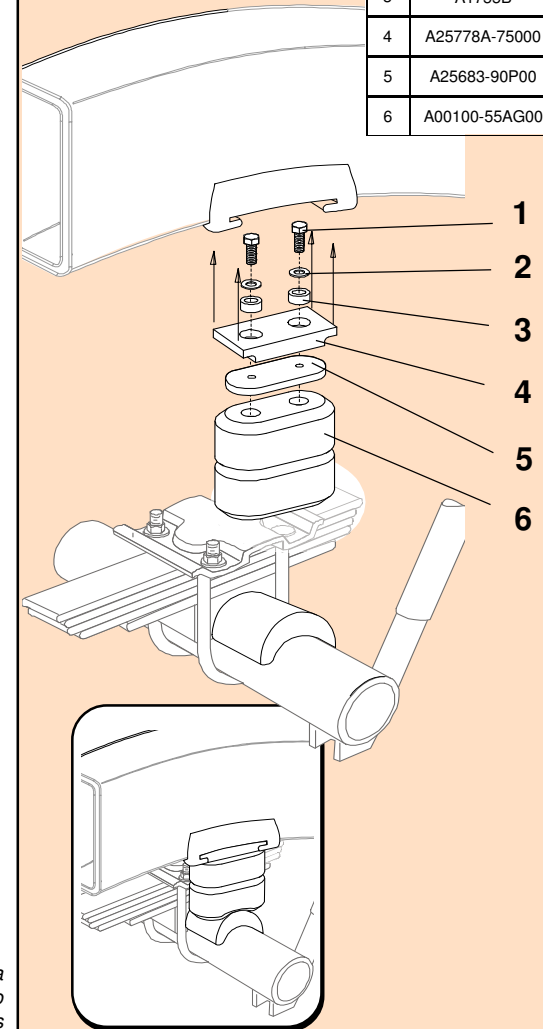

MBRSP35A 

MBRSP35A

TIMBREN INDUSTRIES INC.

www.timbren.com

PART NUMBER	DESCRIPTION	QTY	LOCATION
A1755B	B BUSHING .406 x .625 x .281	4	Bushing Shelf
F40031-020	WASHER FLAT USS 3/8 x 1 GR 2 Z	4	G1C
F13538-753	SHCS M10 x 40 x 1.5 F/T GR 8.8 B	4	J1C

A00100-55AG00	HOLLOW RUBBER SPRING	2	C13C
A25778A-75000	AEON LOCATOR 4-1/4 x 3-1/8 x 3/4 THK	2	F4C
A25683-90P00	AEON LOCATOR W/ P BUSHING	2	

B90200-CR	SMALL REAR BOX - 9.5 x 7 x 5.5	1	A--E
B10000	8" x 12" BUBBLE FOR KITS	1	
B00029-010	BARCODE LABEL FOR KIT	1	

Issued: 10/30/2014

Clearance Instructions:

Rear SES Kits for Pick-Ups and Vans should have a 1/2" to 1-1/2" gap between the rubber spring and contact point when empty.

A partial load, or vehicle accessories will reduce or eliminate the gap.

Front SES kits are usually in full contact.

Medium and Heavy-Duty Trucks, Trailers and Motorhomes will be in constant contact, and have no gap.

Lifetime Warranty:

Timbren SES Kits are warranted against defects in material and workmanship, under normal use and service, for the life of the vehicle on which the kit was originally installed. The warranty is not transferable and proof of purchase is required. The warranty is limited to the replacement of the failed part.

TIMBREN will not be responsible for any labour or freight charges involved in the replacement of any product. TIMBREN shall be entitled to make its own inspection to determine the validity of the claim. TIMBREN shall not be liable nor warranty the product in the event of alteration, misuse, overload, negligence or damage caused by others.

If ride or performance of our product is unsatisfactory in any way, please call: 1-800-263-3113 or email sales@timbren.com

ASSEMBLY NOTES:

**KIT PRE-ASSEMBLED
USE LOCTITE**