

51 Winthrop Road
Chester, Connecticut 06412-0684
Phone: (860) 526-9504
Sales Email: autosale@whelen.com
Canadian Sales: canadiansales@whelen.com
Customer Service: custserv@whelen.com

Safety First: This document provides all the necessary information to allow your Whelen product to be properly and safely installed. Before beginning the installation and/or operation of your new product, the installation technician and operator must read this manual completely. Important information is contained herein that could prevent serious injury or damage.

- Proper installation of this product requires the installer to have a good understanding of automotive electronics, systems and procedures.
- Whelen Engineering requires the use of waterproof butt splices and/or connectors if that connector could be exposed to moisture.
- Failure to use specified installation parts and/or hardware will void the product warranty!
- If mounting this product requires drilling holes, the installer MUST be sure that no vehicle components or other vital parts could be damaged by the drilling process. Check both sides of the mounting surface before drilling begins. Also de-burr any holes and remove any metal shards or remnants. Install grommets into all wire passage holes.
- Do not install this product or route any wires in the deployment area of your air bag. Equipment mounted or located in the air bag deployment area will damage or reduce the effectiveness of the air bag, or become a projectile that could cause serious personal injury or death. Refer to your vehicle owner's manual for the air bag deployment area. The User/Installer assumes full responsibility to determine proper mounting location, based on providing ultimate safety to all passengers inside the vehicle.
- For this product to operate at optimum efficiency, a good electrical connection to chassis ground must be made. The recommended procedure requires the product ground wire to be connected directly to the NEGATIVE (-) battery post.
- Do not attempt to activate or control this device in a hazardous driving situation.
- If this product uses a remote device to activate or control this product, make sure that this control is located in an area that allows both the vehicle and the control to be operated safely in any driving condition.
- This product contains either strobe light(s), halogen light(s), high-intensity LEDs or a combination of these lights. Do not stare directly into these lights. Momentary blindness and/or eye damage could result.
- Use only soap and water to clean the outer lens. Use of other chemicals could result in premature lens cracking (crazing) and discoloration. Lenses in this condition have significantly reduced effectiveness and should be replaced immediately. Inspect and operate this product regularly to confirm its proper operation and mounting condition. Do not use a pressure washer to clean this product.
- WARNING!** All customer supplied wires that connect to the positive (+) terminal of the battery must be sized to supply at least 125% of the maximum operating current and **FUSED** "at the battery" to carry that load. **DO NOT USE CIRCUIT BREAKERS WITH THIS PRODUCT!**
- FAILURE TO FOLLOW THESE PRECAUTIONS AND INSTRUCTIONS COULD RESULT IN DAMAGE TO THE PRODUCT OR VEHICLE AND/OR SERIOUS INJURY TO YOU AND YOUR PASSENGERS!**

Mounting

- Using the dimensions below, mark the mounting and wire hole locations onto the proposed mounting surface. Drill two, .250" diameter mounting holes and a 1.75" (minimum) wire access hole into the mounting surface.
- Place the appropriate gasket into position on the rear of the M6V assembly (see Gasket Note). Insert the slotted hole screw grommet through the mounting holes on the M6/Gasket assembly so that it is flush with the lens.
- Feed the M6V wires through the wire access hole in the mounting surface. Press the M6V/Gasket/Grommet assembly onto its mounting location so that it is flat against the mounting surface. With the assembly in position and using the hardware provided, tighten the mounting screws until the lighthouse assembly is drawn firmly against the mounting surface. A torque value of 12 in-lb. (max.) is typically required to achieve this. **DO NOT OVER TIGHTEN!**
- Using appropriately sized wires (minimum 18 AWG), extend the M6V wires to their designated connections. Refer to the diagram shown for wiring and fusing information.

RED - Warning Light: Apply +VBAT to the RED wire to activate the Warning light.

WHT/BLK - Perimeter Light: Apply +VBAT to activate the Perimeter light.

BLK or BLK/WHT - Ground: Connect this wire to Chassis Ground

VIOLET - Low Power : The type of switch used depends on how the operator wishes Low Power to function:

Latching Mode: By applying +VBAT to the VIO wire for less than 1 sec., the lighthouse is "latched" into low power. The unit must be turned off and then back on to restore normal operation. For this mode, a momentary switch is preferred.

Level Mode: Applying +VBAT to the VIO wire for more than 1 sec. holds the lighthouse in low power mode until voltage is removed. For this mode, a toggle switch is preferred.

WHT/VIO - ScanLock™ Pattern Selection: This feature allows the user to select from several available flash patterns. Lighthouse must be switched on for Scan-Lock to work.

TO CYCLE THROUGH ALL PATTERNS: Apply +VBAT to the WHT/ VIO wire for less than 1 second and release. To cycle backward through patterns apply +VBAT to the WHT/VIO wire for over 1 second and release.

TO SET A PATTERN AS DEFAULT: Allow the pattern to run for more than 5 seconds. The lighthouse will now display this pattern when active.

TO RESET TO THE FACTORY DEFAULT PATTERN: Turn off power. While applying +VBAT to the WHT/VIO wire, turn power on. The lighthouse will reset to its default pattern.

GREY - SYNC: To SYNC 2 lighthouses, configure both lighthouses to display the same Phase 1 (Simultaneous) pattern. Turn power off and connect the GREY wire from each lighthouse together. Activate the lighthouses and their patterns will be synchronized. To configure 2 lighthouses to alternate their patterns, advance either lighthouse to Phase 2 (Alternating) of the current pattern. Cut and insulate this wire if not used.

Waterproof butt splices and/or connectors are required if that connection could be exposed to moisture. Any unused wires must be sealed (waterproofed) to prevent moisture infiltration.

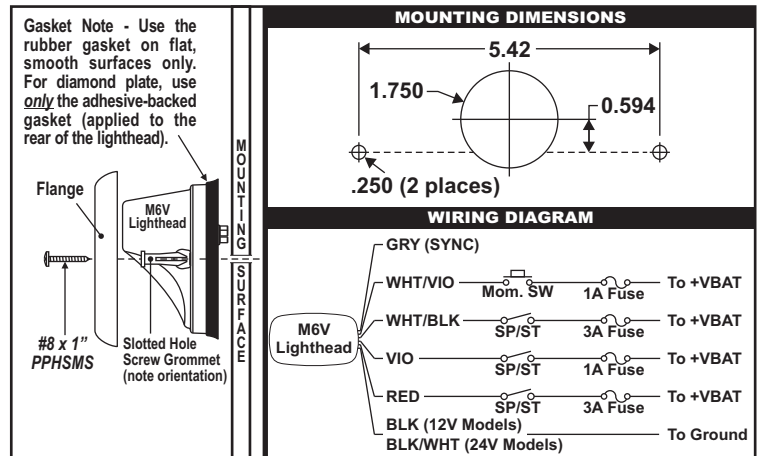

Pattern List:

#	Name	Cert.	#	Name	Cert.
1.	SignalAlert™ PH1	1,2,3,4	17.	SingleFlash 60	1,2, 4
2.	SignalAlert PH2	1,2,3,4	18.	SingleFlash 90	1,2,3,4
3.	ComAlert™ 75 PH1	1,2,3,4	19.	SingleFlash 120	1,2,3,4
4.	ComAlert 75 PH2	1,2,3,4	20.	SingleFlash 240	1, 3,4
5.	Comet Flash® PH1	1,2,3,4	21.	DoubleFlash 120	1,2,3,4
6.	Comet Flash PH2	1,2,3,4	22.	Tripleflash 120	1,2,3,4
7.	LongBurst™ PH1	1,2,3,4	23.	ComAlert™ 150	1, 3,4
8.	LongBurst PH2	1,2,3,4	24.	PingPong™ 120	1,2,3,4
9.	PingPong™ 75 PH1	1,2,3,4	25.	ActionFlash™ 60	1,2, 4
10.	PingPong 75 PH2	1,2,3,4	26.	ActionFlash 120	1,2,3,4
11.	SingleFlash 75 PH1	1,2,3,4	27.	Action SF 60/120	1,2, 4
12.	SingleFlash 75 PH2	1,2,3,4	28.	Action SF 120/TF75	1,2,3,4
13.	DoubleFlash 75 PH1	1,2,3,4	29.	ModuFlash	
14.	DoubleFlash 75 PH2	1,2,3,4	30.	CalScan	1,2,3,4
15.	TripleFlash™ 75 PH1	1,2,3,4	31.	ActionScan	1, 3,4
16.	TripleFlash 75 PH2	1,2,3,4	32.	STEADY	

Bold = SYNC Pattern
PH1 = Phase 1 PH2 = Phase 2

Note: Each pattern is certified compliant in up to 4 classifications, shown in the "Cert" column:

- SAE
- CA Title XIII
- NFPA
- KKK

IMPORTANT WARNING!

CAUTION! DO NOT LOOK DIRECTLY AT THESE LEDS WHILE THEY ARE ON. MOMENTARY BLINDNESS AND/OR EYE DAMAGE COULD RESULT!

Warnings to Installers

Whelen's emergency vehicle warning devices must be properly mounted and wired in order to be effective and safe. Read and follow all of Whelen's written instructions when installing or using this device. Emergency vehicles are often operated under high speed stressful conditions which must be accounted for when installing all emergency warning devices. Controls should be placed within convenient reach of the operator so that he can operate the system without taking his eyes off the roadway. Emergency warning devices can require high electrical voltages and/or currents. Properly protect and use caution around live electrical connections. Grounding or shorting of electrical connections can cause high current arcing, which can cause personal injury and/or vehicle damage, including fire. Many electronic devices used in emergency vehicles can create or be affected by electromagnetic interference. Therefore, after installation of any electronic device it is necessary to test all electronic equipment simultaneously to insure that they operate free of interference from other components within the vehicle. Never power emergency warning equipment from the same circuit or share the same grounding circuit with radio communication equipment. All devices should be mounted in accordance with the manufacturer's instructions and securely fastened to vehicle elements of sufficient strength to withstand the forces applied to the device. Driver and/or passenger air bags (SRS) will affect the way equipment should be mounted. This device should be mounted by permanent installation and within the zones specified by the vehicle manufacturer, if any. Any device mounted in the deployment area of an air bag will damage or reduce the effectiveness of the air bag and may damage or dislodge the device. Installer must be sure that this device, its mounting hardware and electrical supply wiring does not interfere with the air bag or the SRS wiring or sensors. Mounting the unit inside the vehicle by a method other than permanent installation is not recommended as unit may become dislodged during swerving; sudden braking or collision. Failure to follow instructions can result in personal injury. Whelen assumes no liability for any loss resulting from the use of this warning device. **PROPER INSTALLATION COMBINED WITH OPERATOR TRAINING IN THE PROPER USE OF EMERGENCY WARNING DEVICES IS ESSENTIAL TO INSURE THE SAFETY OF EMERGENCY PERSONNEL AND THE PUBLIC.**

Warnings to Users

Whelen's emergency vehicle warning devices are intended to alert other operators and pedestrians to the presence and operation of emergency vehicles and personnel. However, the use of this or any other Whelen emergency warning device does not guarantee that you will have the right-of-way or that other drivers and pedestrians will properly heed an emergency warning signal. Never assume you have the right-of-way. It is your responsibility to proceed safely before entering an intersection, driving against traffic, responding at a high rate of speed, or walking on or around traffic lanes. Emergency vehicle warning devices should be tested on a daily basis to ensure that they operate properly. When in actual use, the operator must ensure that both visual and audible warnings are not blocked by vehicle components (i.e.: open trunks or compartment doors), people, vehicles, or other obstructions. It is the user's responsibility to understand and obey all laws regarding emergency warning devices. The user should be familiar with all applicable laws and regulations prior to the use of any emergency vehicle warning device. Whelen's audible warning devices are designed to project sound in a forward direction away from the vehicle occupants. However, because sustained periodic exposure to loud sounds can cause hearing loss, all audible warning devices should be installed and operated in accordance with the standards established by the National Fire Protection Association.