

**Mounting:**

1. Remove the existing 700 series lighthood and gasket from the mounting surface.
2. Mark the M7 flange mounting hole locations onto the mounting surface by using the flange as a template or using the measurements shown.
3. Drill four 1/4 inch mounting holes and insert the four supplied #8 round hole grommets.

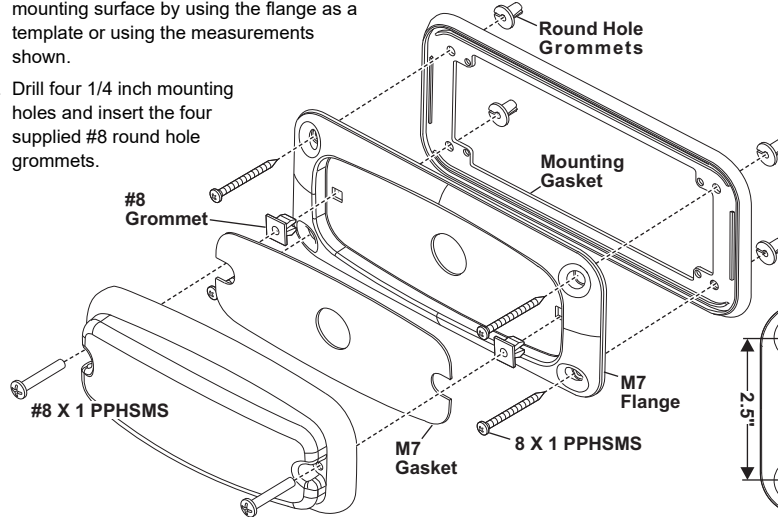

4. Insert the two #8 square grommets into the flange and secure the lighthood to the flange with two #8 X 1" sheet metal screws.  
**NOTE: Due to the mounting hole locations for the M Series and the variety of lighthood styles which may be replaced, cutting or drilling may be required for the screws going into the square grommets.**
5. Secure the Flange and lighthood to the vehicle with the 4 supplied #8 X 1" sheet metal screws and round grommets you installed in step 3.
6. Extend the wires to your power source and connect as shown in the lighthood manual.

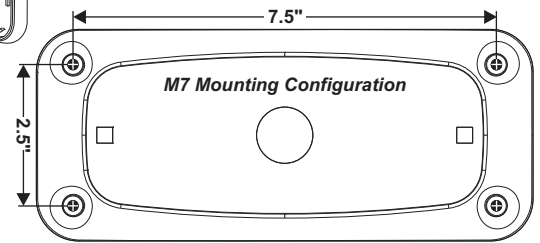

©2009 Whelen Engineering Company Inc.  
Form No.14337 (080409)

**For warranty information regarding this product, visit [www.whelen.com/warranty](http://www.whelen.com/warranty)**

**Mounting:**

1. Remove the existing 700 series lighthood and gasket from the mounting surface.
2. Mark the M7 flange mounting hole locations onto the mounting surface by using the flange as a template or using the measurements shown.
3. Drill four 1/4 inch mounting holes and insert the four supplied #8 round hole grommets.

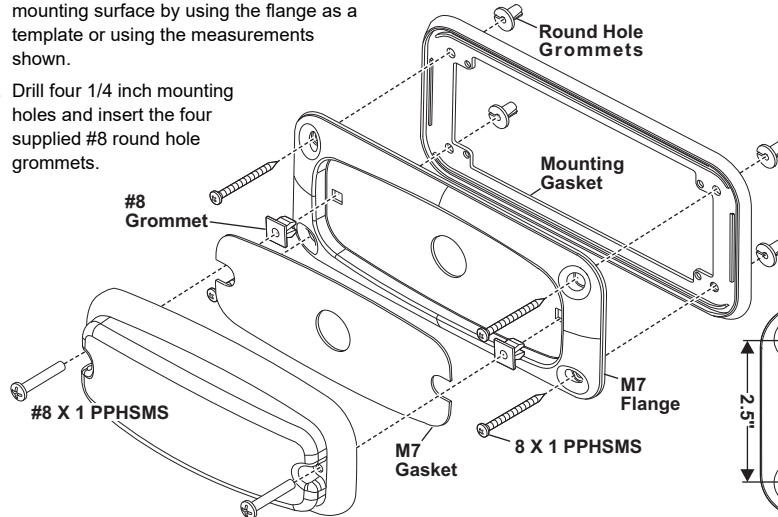

4. Insert the two #8 square grommets into the flange and secure the lighthood to the flange with two #8 X 1" sheet metal screws.  
**NOTE: Due to the mounting hole locations for the M Series and the variety of lighthood styles which may be replaced, cutting or drilling may be required for the screws going into the square grommets.**
5. Secure the Flange and lighthood to the vehicle with the 4 supplied #8 X 1" sheet metal screws and round grommets you installed in step 3.
6. Extend the wires to your power source and connect as shown in the lighthood manual.

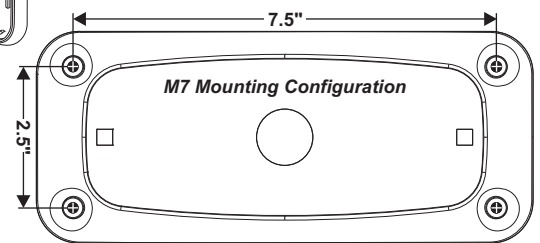

©2009 Whelen Engineering Company Inc.  
Form No.14337 (080409)

**For warranty information regarding this product, visit [www.whelen.com/warranty](http://www.whelen.com/warranty)**