

Pitman Arm Master Service Kit

20388

**TIGER
TOOL**

Have What It Takes

Safety Warning

Read all instructions and safety warnings prior to operation. Failure to do so could result in equipment damage, personal injury or even death.

CAUTION: ALWAYS KEEP THE FORCING SCREW THREADS CLEAN AND WELL LUBRICATED. LUBRICATE WITH OIL BEFORE EVERY USE. FAILURE TO DO SO CAN RESULT IN THREAD SEIZURE IN THE TOOL.

- **Stay Alert!** Watch what you are doing and use common sense when operating this tool.
- Inspect product for damage prior to using; do not use if product is in unsafe condition.
- Do not operate tool while under the influence of drugs, alcohol or medication.
- Always use safety equipment to prevent injuries. Approved face and eye protection must always be worn by the operator, as well as others in the work area.
- Do not overreach. Keep proper footing and balance at all times.
- Dress properly. Do not wear loose clothing or jewelry. Keep your hair, clothing and gloves away from moving parts.
- Keep your work area clean and well lit.



View demonstration videos and a complete product list at tigertool.com

Technical Support
1.800.661.4661

Pitman Arm Master Service Kit

20388

**TIGER
TOOL**

Have What It Takes

Operating Instructions

Pitman Arm Puller (M100): 10385

CAUTION: Always keep the forcing screw threads clean and well lubricated. Lubricate with oil before every use. Failure to do so can result in thread seizure in the tool.

- 1 Remove set screws from pitman arm or bend lock tabs for removal of retaining bolt. Refer to the manufacturer's service manual to determine model and retaining method.
- 2 Some applications may also require removal of some/all of the fasteners in the sector shaft cover to allow the tool to slide over the pitman arm.
- 3 Back the forcing screw out and slip casting over the pitman arm until the forcing screw lines up with the center of the sector shaft. Ensure that the forcing screw will not damage the threads in the end of the sector shaft. On some models, it may be necessary to install a bolt into the threaded end of the sector shaft for the pulling operation.
- 4 Once the tool is properly positioned on the pitman arm, apply $\frac{1}{2}$ " drive impact to the forcing screw until the pitman arm is removed from the sector shaft.



Pitman Arm Spreader: 10386

CAUTION: Keep the threads of the screw clean and lubricated at all times to lessen friction. Use quality oil on threads. We do not recommend using anti-seize!

- 1 Remove the nut from the thru bolt.
- 2 Remove the thru bolt from the pitman arm.
- 3 Slide the two link arms onto each side of the pulling bar with the pulling pins entering the thru bolt hole of the pitman arms. Align the wedge with the parting line of the pitman arm and hand tighten the screw until the assembly is tight and in proper position.
- 4 Continue to turn the forcing screw with a wrench or air ratchet until the wedge has spread the pitman arm sufficiently to allow the pitman arm to be removed. Use caution not to spread the arm excessively.



Refer to steering box manufacturer's service instructions or vehicle service manual for further information.



View demonstration videos and a complete product list at tigertool.com

Technical Support
1.800.661.4661

Pitman Arm Master Service Kit

20388

**TIGER
TOOL**

Have What It Takes

Pitman Arm Puller (Intermediate): 10388

CAUTION: Always keep the forcing screw threads clean and well lubricated. Lubricate with oil before every use. Failure to do so can result in thread seizure in the tool.

- 1 Remove the retaining nut and washer from the sector arm.
- 2 Back out the forcing screw. Slip casting over the pitman arm until the forcing screw lines up with the center of the sector shaft.
- 3 Once the tool is properly positioned on the pitman arm, apply $\frac{1}{2}$ " drive impact to the forcing screw until the pitman arm is removed from the sector shaft.



Pitman Arm Puller (M110): 10389

CAUTION: Always keep the forcing screw threads clean and well lubricated. Lubricate with oil before every use. Failure to do so can result in thread seizure in the tool.

- 1 Refer to the manufacturer's service manual to determine model and retaining method.
- 2 Some applications may also require removal of some/all of the fasteners in the sector shaft cover to allow the 10389 tool to slide over the pitman arm.
- 3 Back forcing screw out and slip casting over the pitman arm until the forcing screw lines up with the center of the sector shaft. Ensure that the forcing screw will not damage the threads in the end of the sector shaft. On some models, it may be necessary to install a bolt into the threaded end of the sector shaft for the pulling operation.
- 4 Once the tool is properly positioned on the pitman arm, apply $\frac{1}{2}$ " drive impact to the forcing screw until the pitman arm is removed from the sector shaft.



Here at Tiger Tool, your satisfaction is our number one priority. Should you have any questions about this or any of our products, please call us at 1.800.661.4661.



View demonstration videos and a complete product list at tigertool.com

Technical Support
1.800.661.4661

Pitman Arm Puller - Sheppard M100



10385

Have What It Takes

Parts Breakdown

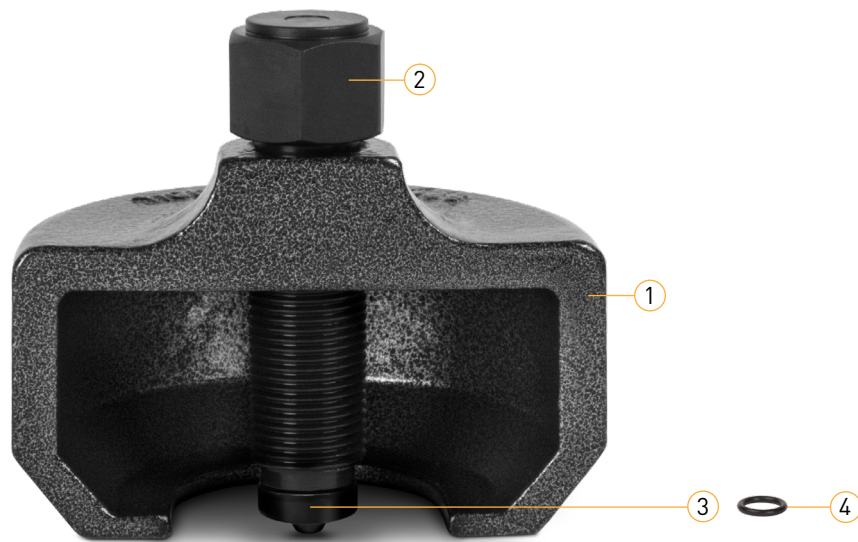

Item No.	Part Number	Description	Qty.
1	10385-1	Body	1
2	10385-2	Forcing Screw	1
3	10385-3	Anvil	1
4	90150-11	010 O-Ring	1



View demonstration videos and a complete product list at tigertool.com

Technical Support
1.800.661.4661

Pitman Arm Spreader

10386

**TIGER
TOOL**

Have What It Takes

Parts Breakdown

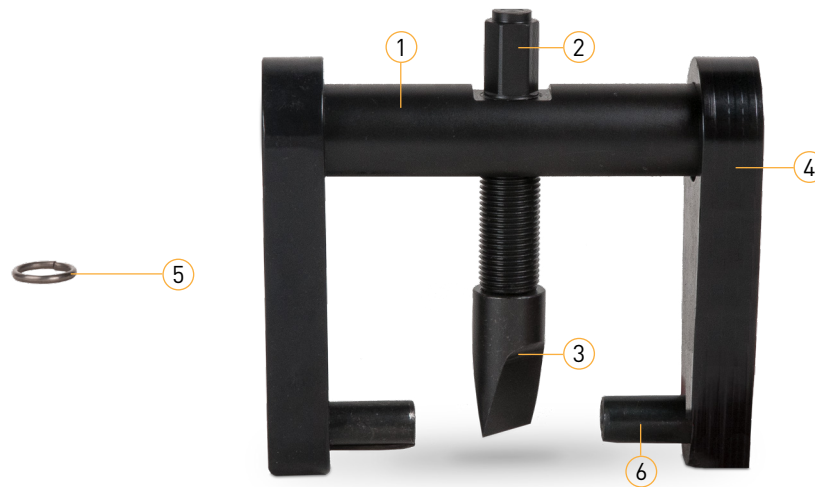

Item No.	Part Number	Description	Qty.
1	10386-1	Pull Bar	1
2	10386-2	Forcing Screw	1
3	10386-3	Anvil	1
4	10386-4	Link Arm	2
5	10386-5	Wire Ring	1
6	10386-7	½" Coil Pin	2



View demonstration videos and a complete product list at tigertool.com

Technical Support
1.800.661.4661

Intermediate Pitman Arm Puller

10388

**TIGER
TOOL**

Have What It Takes

Parts Breakdown



Item No.	Part Number	Description	Qty.
1	10388-1	Body	1
2	10406-2	Forcing Screw	1



View demonstration videos and a complete product list at [tigertool.com](https://www.tigertool.com)

Technical Support
1.800.661.4661

Pitman Arm Puller - Sheppard M110



10389

Have What It Takes

Parts Breakdown



Item No.	Part Number	Description	Qty.
1	10389-1	Body	1
2	10406-2	Forcing Screw	1



View demonstration videos and a complete product list at tigertool.com

Technical Support
1.800.661.4661