



Ramsey Winch Company OWNER'S MANUAL Front and Rear Mount Detachable Electric Winch Model Quick-Mount 5000H™ (QM5000H)



Layer of Cable		1	2	3	4
Rated Line Pull Per Layer	(lbs)	5,000	4,200	3,600	3,200
	(kg)	2,260	1,900	1,630	1,450
Cumulative Cable Capacity Per Layer 1/4" (6mm) dia. Cable	(ft)*	15	30	55	80
	(m)*	4	9	16	24

First Layer Line Pull		(lbs) (kg)	NO	1,000	3,000	5,000
			LOAD	450	1,350	2,260
Line Speed First Layer	(FPM) 12V		39	31	8	6
	(MPM) 12V		11.8	9.4	2.4	1.8
	(FPM) 24V		47	26	21	12
	(MPM) 24V		14.3	7.9	6.4	3.6
Amp Draw	12V		72	180	295	420
	24V		38	87	124	184

* Depends on cable being uniformly wound onto drum. Ramsey performance data is compiled from actual winch testing.

Congratulations

You have purchased the finest winch available in its service class. The OM 5000™ is a 5,000 lb. rated detachable winch. It can be easily mounted to the front and rear of vehicle for self-recovery and multiple applications. It allows one winch to be used on multiple vehicles, and can be quickly installed and removed to avoid extra vehicle weight.

The Quick Mount is available in either a 5,000 lb. rating with, 80ft. of 1/4 inch galvanized aircraft wire cable. Standard with the OM 5000™ is a 12 ft. remote control switch, anti-theft locking pin, 2 ft. battery cables (optional 20ft. battery cables for rear mount) and a hawse fairlead. Front mount requires a standard receiver mounting kit. A standard ball hitch can be used with rear mounted OM 5000™ to assist with loading and unloading.

The QM 5000™ winch features a highly efficient 3 stage planetary gear set which transmits torque from a series wound D.C. motor (QM 5000). A positive clutch allows free spooling for quick cable deployment. An automatic load holding brake is designed to hold the full rated capacity of the winch. It was designed and manufactured to provide you with the utmost in utility.

As with any device that combines power and movement in use, there are dangers if improperly used. At the same time, there are easier and faster ways for getting the job done if certain precautions are taken first.

Please read this manual carefully. It contains useful ideas in obtaining the most efficient operation from your Ramsey winch and safety procedures you need to know before beginning use. When you follow our guidelines for operation, your Ramsey winch will give you many years of service. Thank you for choosing Ramsey. You will be glad you have one working for you!

Contents

Performance Specifications.....	Front Cover
Safety Precautions	3
Tips for Safe Operation	3
Techniques of Operation	4
Installation	5
Clutch Operation	5
Remote Control Switch Operation.....	5
Care and Maintenance	5
Assembling Your Winch	6
Lubrication/Cable Installation	7
Troubleshooting Guide	7
Winch Parts List	8-9
Warranty	Back Cover

SAFETY PRECAUTIONS & OPERATION TIPS



Safety Precautions To Guard Against Possible Injury . . .

A minimum of five wraps of cable around the drum barrel is necessary to hold the rated load. Cable clamp is not designed to hold the load.

- A. Secure Quick Mount locking pin into place before starting winching operation.
- B. Use only locking pin #448097.
- C. Front mount receiver is for use with the Quick Mount winch only. Do not use for towing.
- D. Keep yourself and others a safe distance to the side of the cable when pulling under load.
- E. Do not step over a cable, or near a cable under load.
- F. Do not move the vehicle to pull a load on the winch cable. This could result in cable breakage and/or winch damage.
- G. Use a heavy rag or gloves to protect hands from burrs when handling winch cable.
- H. Apply blocks to wheels when vehicle is on an incline.
- I. Winch clutch should be disengaged when winch is not in use and fully engaged when in use.
- J. Modification, alteration, or deviation to the winch should only be made by Ramsey Winch Company.
- K. Keep the duration of your pulls as short as possible. If the motor becomes uncomfortably hot to the touch, stop and let it cool for a few minutes. Do not pull more than one minute at or near the rated load. Do not maintain power to the winch if the motor stalls. Electric winches are for intermittent usage and should not be used in constant duty applications.
- L. Disconnect the remote control switch from the winch when not in use. A Ramsey Part No. 282036 battery disconnect switch in your vehicle is recommended.
- M. Do not use winch in hoisting applications due to required hoist safety factors and features.
- N. Do not exceed maximum line pull ratings shown in tables. Shock loads must not exceed these ratings.
- O. To respool correctly, it is necessary to keep a slight load on the cable. This is accomplished by (wearing gloves) holding the cable with one hand and the remote control with the other, starting as far back and in the center as you can, walking up keeping load on

the cable as the winch is powered in. Do not allow the cable to slip through your hand and do not approach the winch too closely. Turn off the winch and repeat the procedure until all the cable except a few feet is in. Disconnect the remote control switch and finish spooling in cable by rotating the drum by hand with clutch disengaged.



Tips for Safe Operation

Do not underestimate the potential danger in winching operations. Neither should you fear them. Do learn the basic dangers and avoid them.

The uneven spooling of cable, while pulling a load, is not a problem, unless there is a cable pileup on one end of drum. If this happens, reverse the winch to relieve the load and move your anchor point further to the center of the vehicle. After the job is done you can unspool and rewind for a neat lay of the cable.

Store the remote control switch inside your vehicle where it will not become damaged. Inspect it before you plug it in.

When ready to begin spooling in, plug in remote control switch with clutch disengaged. Do not engage clutch with motor running.

Never connect the hook back to the cable. This causes cable damage. Always use a sling or chain of suitable strength as shown in the illustration, page 3.

Observe your winch while winching, if possible, while standing at a safe distance. If you use vehicle drive to assist, stop and get out every few feet to assure the cable is not piling up in one corner. Jamming cable can break your winch.

Do not attach tow hooks to winch mounting apparatus. They must attach to vehicle frame.

When double lining during stationary winching, the winch hook should be attached to the chassis of the vehicle.

Since the greatest pulling power is achieved on the innermost layer of your winch, it is desirable to pull off as much line as you can for heavy pulls. If this is not practical, use a snatch block and double line arrangement as shown in the illustration, page 3. Remember, a minimum of 5 wraps of cable around the drum barrel is necessary to hold the rated load.

TECHNIQUES OF OPERATION

Neat, tight spooling avoids cable binding. Cable binding occurs when a cable under load pulls down into the layer below, becoming pinched between two other wraps of cable. If this happens, alternately power the winch in and out a few inches. Do not attempt to work a bound cable under load. Free by hand.

Techniques of Operation

The best way to get acquainted with how your winch operates is to make a few test runs before you actually need to use it. Plan your test in advance. Remember you hear your winch as well as see it operate. Get to recognize the sound of a light steady pull, a heavy pull, and sounds caused by load jerking or shifting. Soon you will gain confidence in operating your winch and its use will become second nature with you.

When pulling a heavy load, place a blanket, jacket or tarpaulin over the cable five or six feet from the hook. It will slow the snap back in the event of a broken cable. Also, open the vehicle hood for additional protection.

Use the vehicle wheel power to help the winch, but don't overtake the winch line. Plan your pull. You cannot always hook up and pull out in one step. Examine the area for anchoring possibilities as well as leverage situations, direction, and goal.

Your winch will not only pull you up or ease you down a steep grade, it will also pull another vehicle or a load while your vehicle is anchored in a stationary position. The following illustrations show a few basic winching techniques.

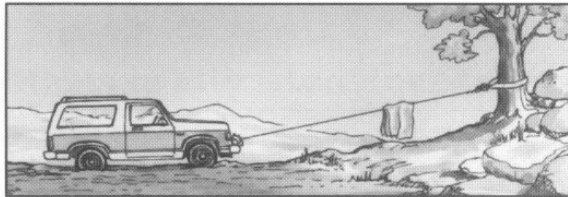

For basic self recovery, anchor to a tree or heavy rock. When anchoring to a tree, always use a tree trunk protector.

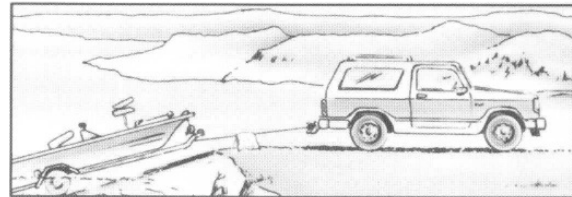

Use for loading and unloading boats, trailers, race cars, etc.

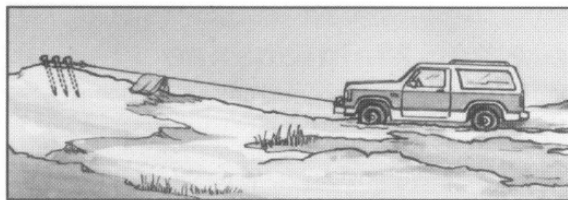

Stakes driven in solid earth and chained together make a good anchor point for self recovery when no solid anchor point is available.

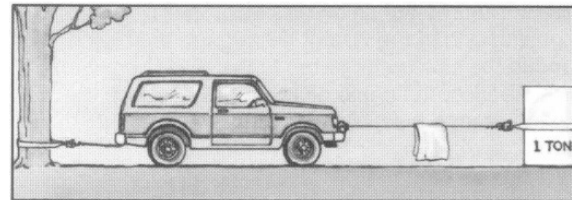

For a direct pull of 2,000 lbs., hitch truck to a tree or solid anchor, and take out of gear.

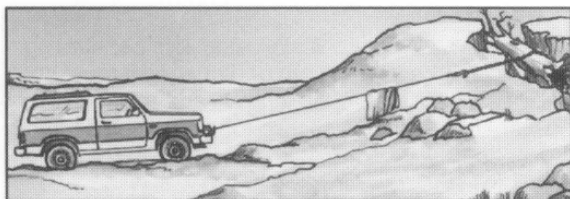

For a solid anchor, bury a log with earth or sand or place it in a deep ravine.

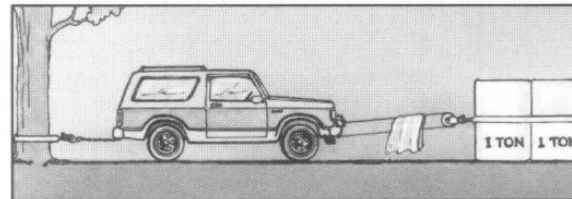

To double the pull, use 2-part line with snatch block and tie off to chassis. Take out of gear.

INSTALLATION/CLUTCH OPERATION/ REMOTE CONTROL

Installation

The Quick Mount™ is solely and exclusively designed for vehicle mounted, non-industrial applications. All other applications will void warranty.

The Quick Mount™ must be front mounted with a front receiver hitch available from Ramsey for select-ed vehicles. For rear mounting of the QM 5000, any standard Class III rear receiver hitch may be used.

For normal self recovery work, your existing electrical system is adequate. Your battery must be kept in good condition. A fully charged battery and proper connections are essential.

For front mounting, route quick connect battery power lead through grille, leaving connector on outside and connect red cable to positive(+) terminal and black cable to negative(-) terminal of battery. Secure cable under hood with cable ties.

For rear mounting connect battery power lead as instructed above. Secure cables under vehicle away from moving parts and exhaust system. Terminate routing near the center of the vehicle at the rear. **BE SURE BATTERY CABLES ARE NOT DRAWN TAUT ACROSS ANY SURFACES WHICH COULD POSSI- BLY DAM- AGE THEM.**

Secure Quick Mount™ in the receiver with the Ramsey locking pin. Connect quick disconnect from Quick Mount™ winch to battery power lead. Plug remote switch into receptacle on solenoid assembly.

Clutch Operation

The winch clutch allows rapid unspooling of the cable for hooking onto the load or anchor point. The clutch is operated by the shifter lever located on the gear housing end of the winch. Disengage the clutch, (move the clutch shifter lever to the "OUT" position.) Free spool some cable off the drum. Engage the clutch, (move the clutch shifter lever to the "IN" position.)

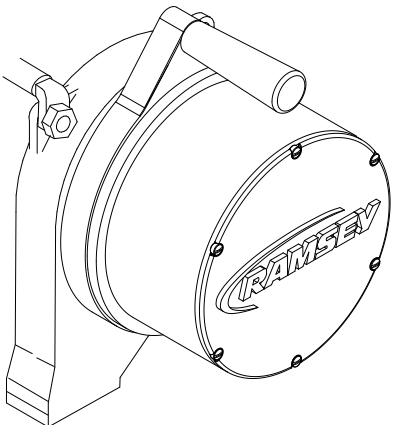

Remote Control Switch Operation

The remote control switch is water proof and has push button stations on either side. It is designed this way to prevent quick winch reversals which lead to premature solenoid failure. The switch is also color coded to aid you in not having to guess at the direction your winch will run. Pushing both buttons at the same time will not damage your winch in any way. Make sure the motor has stopped fully before reversing. Run the winch forward and reverse to check connections. Snap appropriate plastic disc into proper thumb button cavity on remote switch after determining direction of rotation for winch drum.

DO NOT LEAVE SWITCH PLUGGED IN WHEN WINCH IS NOT IN USE.

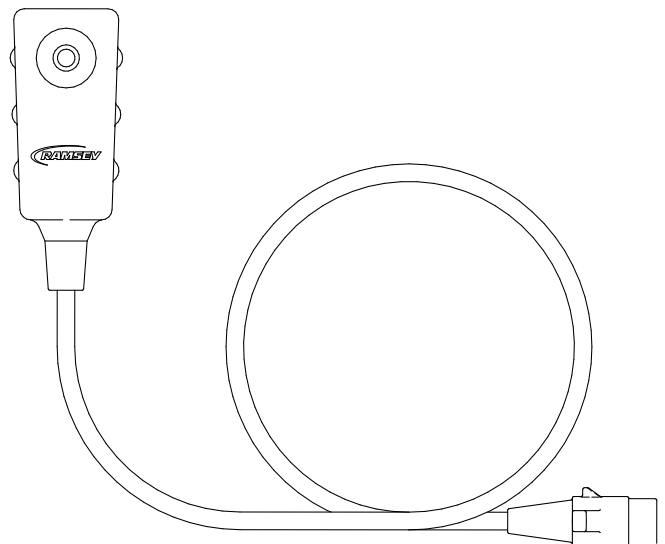

Care and Maintenance

Corrosion on electrical connections will reduce performance or may cause a short. Clean all connections, especially in remote control switch and receptacle. In salty environments use a silicone sealer to protect from corrosion.

All moving parts in the winch are permanently lubricated with high temperature lithium grease at the time of assembly. Under normal conditions, factory lubrication will suffice.

Lubricate the cable periodically using light penetrating oil. If the cable becomes worn or damaged it must be replaced. Inspect for broken strands and replace if necessary (see the next section for cable replacement instructions).

QM5000H™ WINCH ASSEMBLY

Assembling your Winch

To assemble your QM winch to the quick mount channel, attach handles to both ends of the quick mount channel using (2) black 3/8" button head screws for each handle as shown below. Tighten to 20 ft-lbs. torque.

Align the base of the clevis hook with the loop on the end of the wire cable. Run the pin through the clevis hook and the loop. Push the cotter pin through the hole in the pin and bend the cotter pin to lock.

Once the handles are attached, lift the winch into the quick mount channel. Feed the looped end of the prewrapped cable through the fairlead.

Place a 3/8" nut and flatwasher in each of the feet of the winch. Align the four mounting holes in the channel with the feet of the winch. Place a lockwasher on each 3/8" hex head bolt and press a bolt through each mounting hole and start it through a nut in the foot of the winch. Do not tighten until all of the bolts have been started. Tighten evenly to 34 ft-lbs. torque.

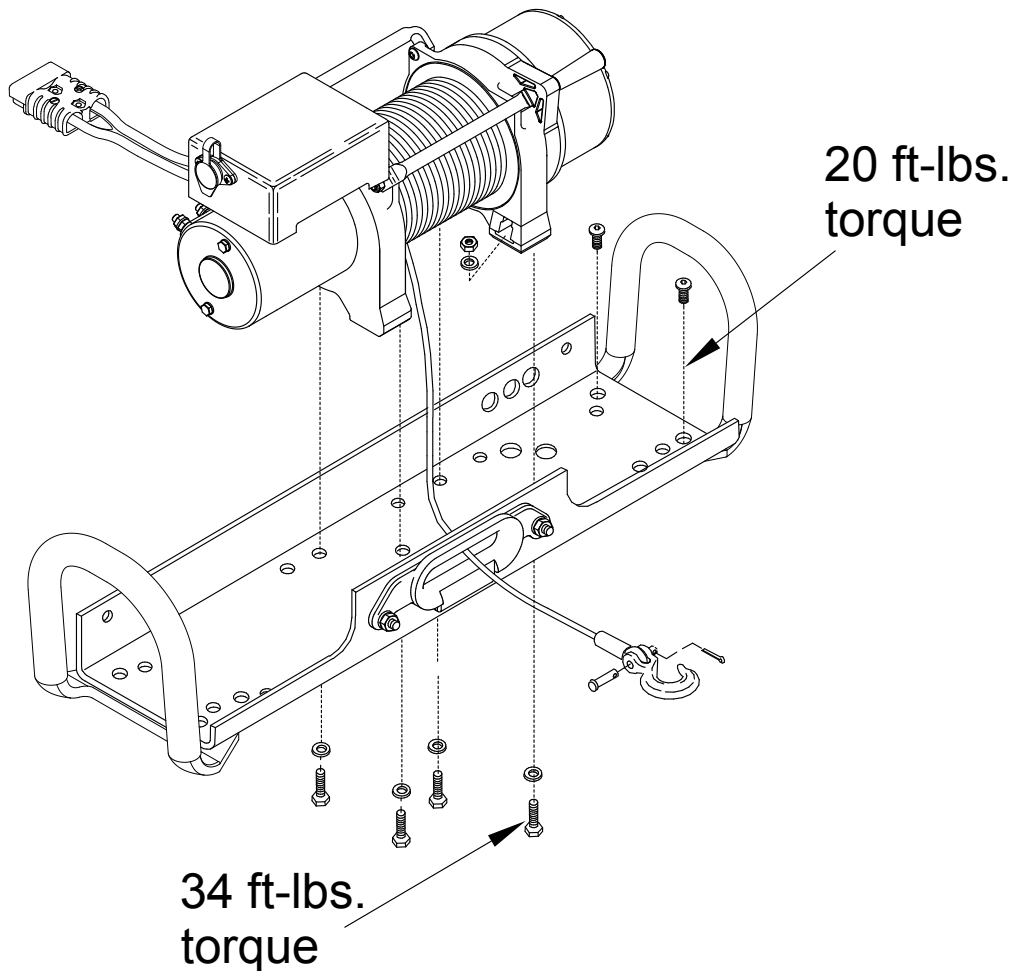

LUBRICATION & CABLE INSTALLATION

Lubrication/Cable Installation

All moving parts in the winch are permanently lubricated with high temperature lithium grease at the time of assembly. Under normal conditions, factory lubrication will suffice. Lubricate cable periodically using light penetrating oil. Inspect for broken strands and replace if necessary with Ramsey part number listed in Parts List. If the cable becomes worn or damaged, it must be replaced.

Unwind the new cable by rolling it out along the ground, to prevent kinking. Remove old cable and observe the manner in which it is attached to the cable drum flange.

Before installing the new cable assembly, make sure end of cable is squarely cut and wrapped with tape to prevent fraying.

Position the cable drum so that the large 13/32" diameter hole in the motor end drum flange is approximately on the top. Form a short bend (approximately 1/2" long) in the end of the cable. Insert the bend into the 13/32" hole in the drum flange and then carefully run the winch in the "reel-in" direction approximately 3/4 revolution until the 1/4" diameter threaded hole in the drum flange is on top. Secure the cable to the drum flange using cable anchor and capscrew. Securely tighten the capscrew but do not overtighten.

Wind 5 wraps of cable onto the drum. Wind on the rest of the cable by pulling in a light load to keep the tension constant. Allow the cable to swivel by using a length of chain or a swivel block between the cable hook and the load.

Troubleshooting Guide

CONDITION	POSSIBLE CAUSE	CORRECTION
MOTOR RUNS IN ONE DIRECTION ONLY	(1) Defective solenoid or stuck solenoid (2) Defective remote control switch	(1) Jar solenoid to free contacts. Check by applying 12 volts to coil terminal (it should make an audible click when energized). (2) Disengage winch clutch, remove remote control switch plug from the socket and jump pins at 8 and 4 o'clock. Motor should run. Jump pins at 8 and 10 o'clock. Motor should run.
MOTOR RUNS EXTREMELY HOT MOTOR RUNS, BUT WITH INSUFFICIENT POWER, OR WITH LOW LINE SPEED	(1) Long period of operation (2) Insufficient battery (3) Bad connection (4) Insufficient charging system	(1) Cooling-off periods are essential to prevent overheating. (2) Check battery terminal voltage under load. If 10 volts or less, replace or parallel another battery to it. (3) Check battery cables for corrosion; clean and grease. (4) Replace with larger capacity charging system.
MOTOR RUNS, BUT DRUM DOES NOT TURN	(1) Clutch not engaged	(1) If clutch engaged but symptom still exists, it will be necessary to disassemble winch to determine cause and repair.
MOTOR WILL NOT OPERATE	(1) Defective solenoid or stuck solenoid (2) Defective remote control switch (3) Defective motor (4) Loose connections	(1) Jar solenoid to free contacts. Check by applying 12 volts to coil terminal (it should make an audible click when energized). (2) Disengage winch clutch, remove remote control switch plug from the socket and jump pins at 8 and 4 o'clock. Motor should run. Jump pins at 8 and 10 o'clock. Motor should run. (3) If solenoids operate, check for voltage at motor posts; replace motor. (4) Tighten connections on motor.
MOTOR WATER DAMAGED	(1) Submerged in water or water from high pressure car wash	(1) Allow to drain and dry thoroughly, then run motor without load in short bursts to dry windings.

QM 5000™ EXPLODED VIEW & PARTS LIST

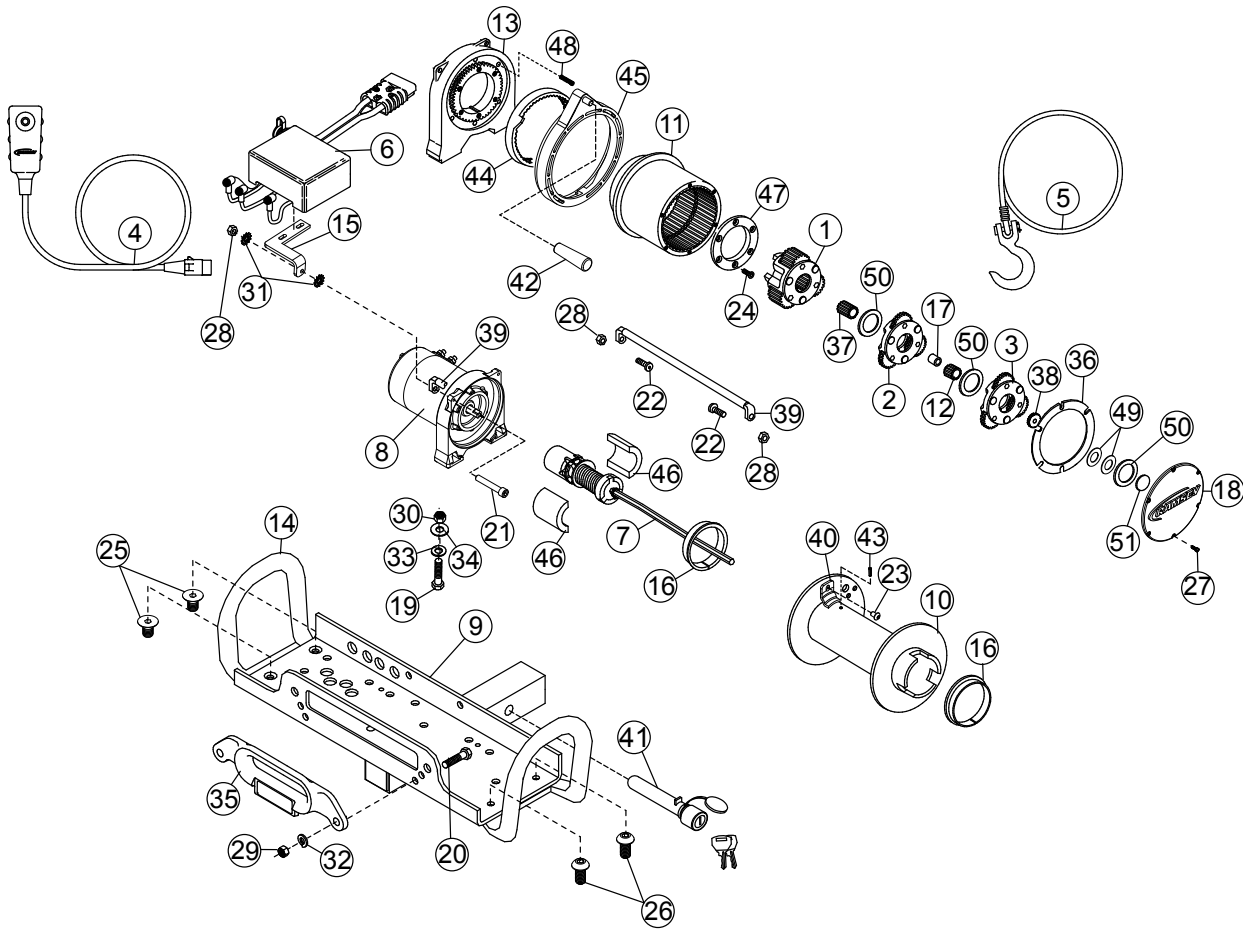

QM 5000 Parts List (12v AND 24v)

Item No.	Qty.	Part No.	Description	Item No.	Qty.	Part No.	Description
1	1	247006	Gear Carrier Assembly - Output	25	2	414900	Screw-3/8-16NC X5/8,Fit SocHd/Fd/Ny
2	1	247007	Gear Carrier Assembly - Intermediate 24v	26	2	414937	Capscrew-3/8-16X3/4,HxSocButtHd
3	1	247024	Gear Carrier Assembly - Input	27	6	416273	Screw - #6-32NC x 3/8
4	1	251110	Switch Assembly - 12 ft	28	4	418018	Nut-1/4-20NC,Hex,Elastic Stop
5	1	251169	Cable Assembly - 80' x 1/4" (6mm) Dia.	29	2	418033	Nut-3/8-16NC,Hex,Reg
6	1	278210	Solenoid Assembly - 12v	30	4	418035	Nut - 3/8-16NC Hx reg Z/P
	1	278211	Solenoid Assembly - 24v	31	2	418165	Washer-5/16 Shake Prf,Ext Teeth,Z/P
7	1	296285	Brake Assembly	32	2	418175	Lockwasher-3/8 Med Sect
8	1	296589	Motor/End Bearing Assembly - 12v	33	4	418177	Lockwasher - 3/8 Med Sect Z/P
	1	296591	Motor/End Bearing Assembly - 24v	34	4	418181	Washer - 3/8 ID SAE Flat Z/P
9	1	299699	Winch Mounting Assembly	35	1	422018	Hawse Fairlead
10	1	332143	Drum - Cable	36	1	442207	Gasket - Gear Housing Cover
11	1	334143	Gear - Ring	37	1	444048	Gear - Output Sun
12	1	334147	Gear - Intermediate Sun	38	1	444097	Gear - Input Sun
13	1	338249	End Bearing	39	2	448061	Tie Bar
14	2	395294	QM Handle	40	1	448071	Cable Anchor
15	1	408315	Bracket-Solenoid Mounting	41	1	448097	Locking Pin
16	2	412056	Bushing - Drum	42	1	452005	Shifter Lever
17	1	412061	Bushing - Shaft	43	1	470053	Roll Pin - 1/8 Dia x 3/8 Lg
18	1	413018	Cover - Gear Housing	44	1	477002	Locking Ring
19	4	414316	Capscrew - 3/8-16NC x 1-1/4 Hx Hd GR5 Z/P	45	1	477013	Cam Ring
20	2	414320	Bolt-3/8-16NCX1 1/4,HxHd,GR5/Xylan Coated	46	2	477004	Ring - Half
21	1	414857	Bolt-1/4-20NCX1 1.5LG HXSOCHD,NYL,ZP	47	1	479007	Retainer - Ring Gear
22	3	414829	Capscrew - 1/4-20NC x 3/4 Soc Button Hd	48	6	494077	Spring
23	1	414830	Capscrew - 1/4-20NC x 3/8 Button Hd	49	2	518019	Thrust Washer
24	6	414861	Capscrew - 1/4-20NC x 3/4 Flat Soc Hd Nylok	50	3	518020	Thrust Washer
				51	1	518027	Thrust Disc

SOLENOID ASSEMBLY PARTS LIST QM5000H™

278210 12 VOLT
278211 24 VOLT

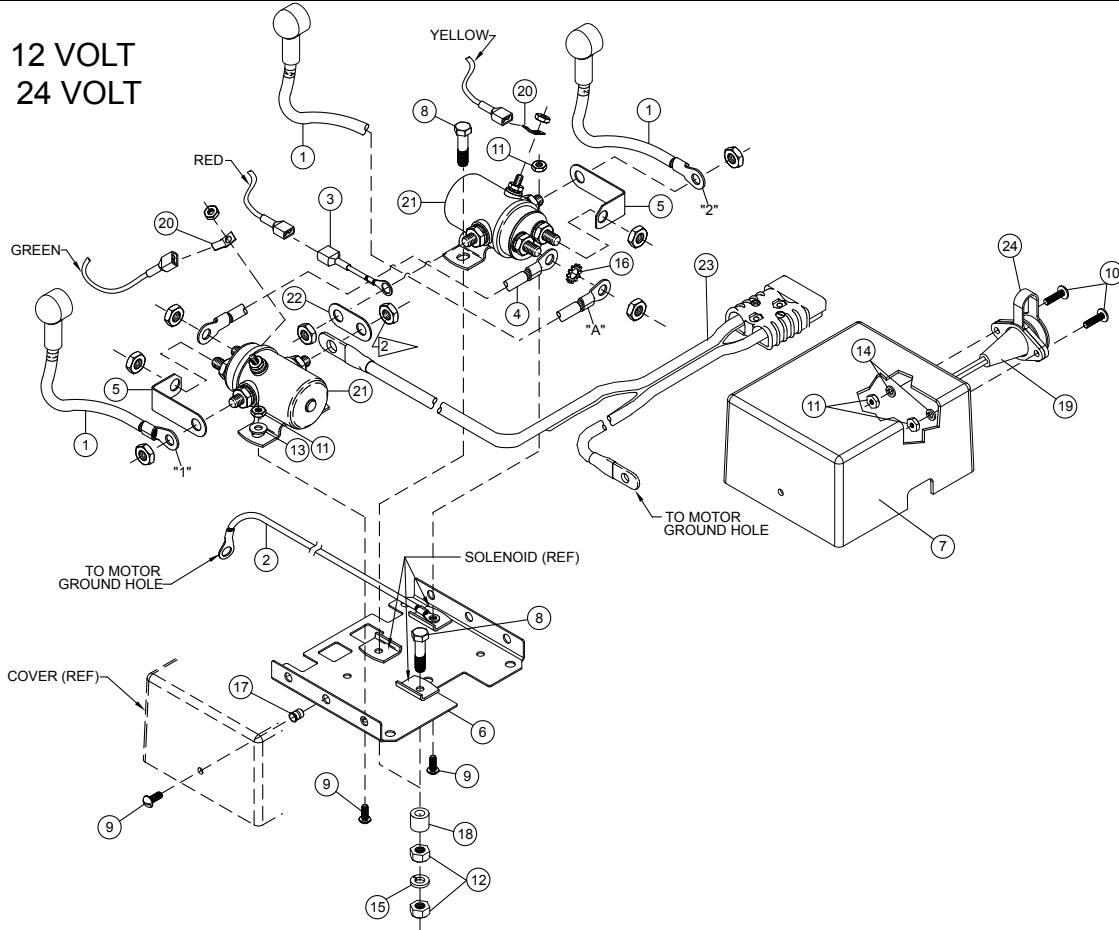

No.	Req'd	Part No.	Description
1	3	289171	Wire Assembly-Black 4 Ga. X 17" Lg.
2	1	289208	Wire Assembly-Black 18 Ga. X 12-1/2" Lg.
3	1	289091	Wire Assembly-Black 16 Ga. X 1-1/2" Lg.
4	1	289092	Wire Assembly-Black 6 Ga. X 3-1/2" Lg.
5	2	364002	Strap-Copper
6	1	408260	Bracket
7	1	413024	Cover-Solenoid
8	2	414062	Capscrew-1/4-20NC X 1-1/2" Lg.HxHd,Z/P,GR5
9	7	416216	Screw-#10-24NC X 1/2" Lg.,Rd.Hd.,Slot,Z/P
10	2	416227	Screw-#10-24NC X 3/4" Lg.Truss Hd. Black
11	6	418004	Nut-Hex #10-24NC Reg. Z/P
12	4	418014	Nut-1/4-20NC Reg. Hex Z/P
13	4	418140	Washer- #10 Flat Steel, SAE, Z/P
14	2	418141	Lockwasher- #10 Med. Section, Plated
15	2	418149	Lockwasher- 1/4 Med. Section, Z/P
16	1	418165	Washer- 5/16 Shake Proof, Ext Teeth, Z/P
17	3	418411	Nutsert- #10-24NC
18	2	418514	Spacer
19	1	430013	Connector Female- Molded
20	2	440071	Terminal Tab
21	2	440110	Solenoid
22	1	440111	Strap-Copper
23	1	440180	Wire Assembly- Quick Disconnect
24	1	482029	Cover- Female Connector

LIMITED WARRANTY

RAMSEY WINCH warrants each new RAMSEY WINCH to be free from defects in material and workmanship for a period of one (1) year from date of purchase.

The obligation under this warranty, statutory or otherwise, is limited to the replacement or repair at the Manufacturer's factory, or at a point designated by the Manufacturer, of such part that shall appear to the Manufacturer, upon inspection of such part, to have been defective in material or workmanship.

This warranty does not obligate RAMSEY WINCH to bear the cost of labor or transportation charges in connection with the replacement or repair of defective parts, nor shall it apply to a product upon which repair or alterations have been made, unless authorized by Manufacturer, or for equipment misused, neglected or which has not been installed correctly.

RAMSEY WINCH shall in no event be liable for special or consequential damages. RAMSEY WINCH makes no warranty in respect to accessories such as being subject to the warranties of their respective manufacturers.

RAMSEY WINCH, whose policy is one of continuous improvement, reserves the right to improve its products through changes in design or materials as it may deem desirable without being obligated to incorporate such changes in products of prior manufacture.

If field service at the request of the Buyer is rendered and the fault is found not to be with RAMSEY WINCH's product, the Buyer shall pay the time and expense to the field representative. Bills for service, labor or other expenses that have been incurred by the Buyer without approval or authorization by RAMSEY WINCH will not be accepted.

See warranty card for details.



Ramsey Winch Company

Post Office Box 581510

Tulsa, Oklahoma 74158-1510

Telephone: (#918) 438-2760 FAX: (#918) 438-6688