

MD MOUNT KIT

16062165

GM 2500/3500

2011-2014



SnowDogg™ Snowplow

TRUCK MOUNT INSTALLATION MANUAL

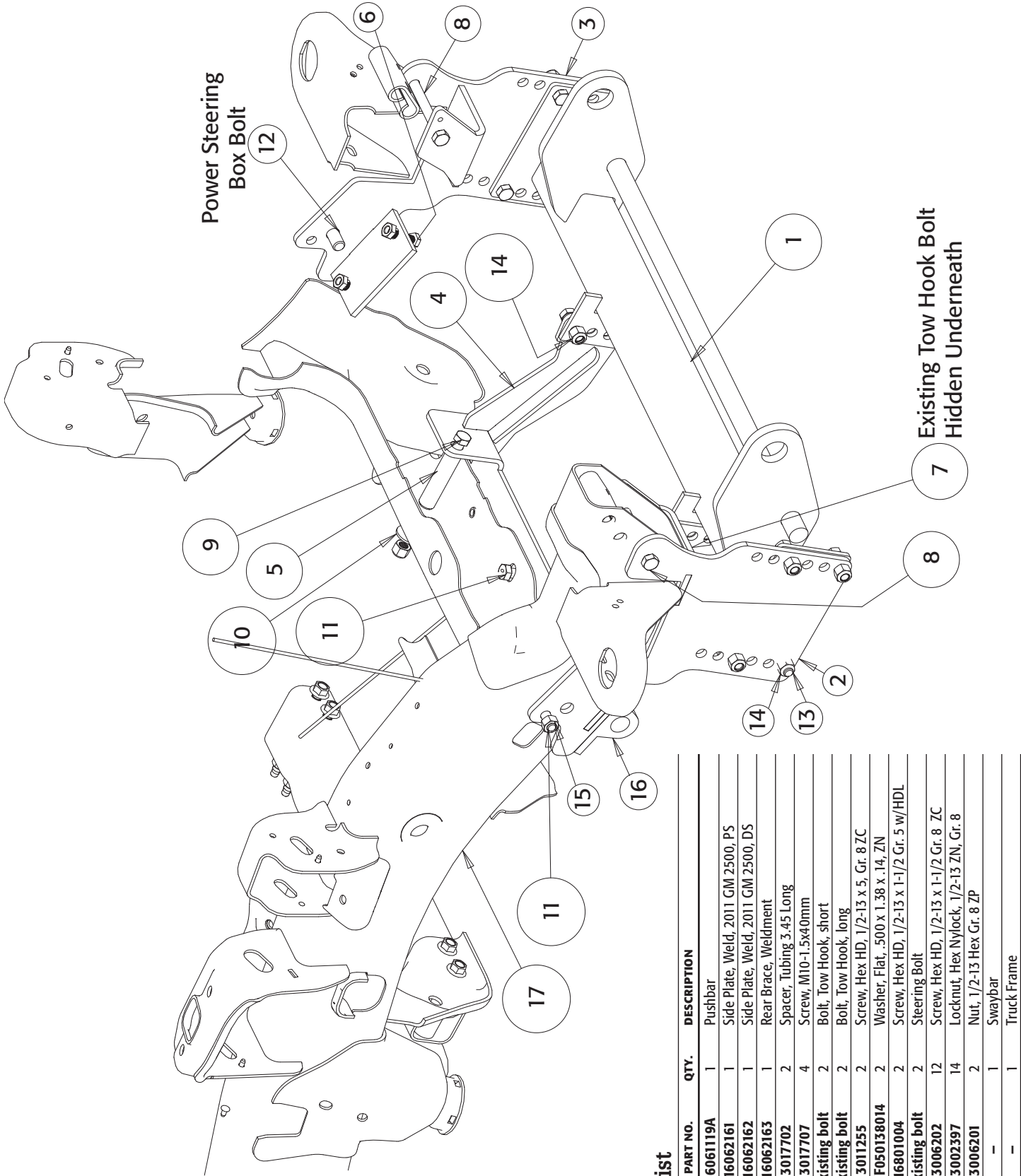

Parts List

ITEM	PART NO.	QTY.	DESCRIPTION
1	1606119A	1	Pushbar
2	16062161	1	Side Plate, Weld, 2011 GM 2500, PS
3	16062162	1	Side Plate, Weld, 2011 GM 2500, DS
4	16062163	1	Rear Brace, Weldment
5	3017702	2	Spacer, Tubing 3.45 Long
6	3017707	4	Screw, M10-1.5x40mm
7	existing bolt	2	Bolt, Tow Hook, short
8	existing bolt	2	Bolt, Tow Hook, long
9	3011255	2	Screw, Hex HD, 1/2-13 x 5, Gr. 8 ZC
10	FWF050138014	2	Washer, Flat, .500 x 1.38 x .14, ZN
11	16801004	2	Screw, Hex HD, 1/2-13 x 1-1/2 Gr. 5 w/HDL
12	existing bolt	2	Steering Bolt
13	3006202	12	Screw, Hex HD, 1/2-13 x 1-1/2 Gr. 8 ZC
14	3002397	14	Locknut, Hex Nylock, 1/2-13 ZN, Gr. 8
15	3006201	2	Nut, 1/2-13 Hex Gr. 8 ZP
16	-	1	Swaybar
17	-	1	Truck Frame

INSTRUCTIONS

1. Remove plastic air deflector from the bumper that is attached to the bottom with some small fasteners. Remove the thin metal Air damper that is attached to the cross member frame of the truck (Keep all fasteners). Air damper must be modified or omitted for installation of this mount kit.
2. Remove the two existing tow hook (tow hook will be needed). Keep both bolts from the tow hook for later re-use on this mount kit.
3. Lower the two sway bar brackets from the bottom of the truck by removing the four bolts from PS and DS frame.

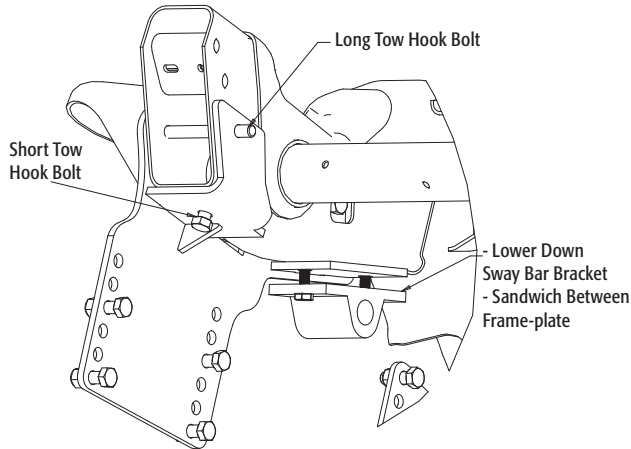

4. Hold the PS Side Plate (2) against the frame, aligning with the long existing bolt-holes from the tow hook. Using the existing bolts, secure it to the frame of the truck. Install the existing short bolt, into the existing tow hook hole from the bottom. Also, align the existing hole from the Sway bar bracket like a sandwich installation. Use the longer M-10 bolts provided.
5. On the side of the truck frame, drill out Ø.531 clearance hole for 1/2" bolts. Ignore the two larger holes. And install the proper 1/2 fasteners (11). In some models, there is one existing hole you can use without using the drilled hole.

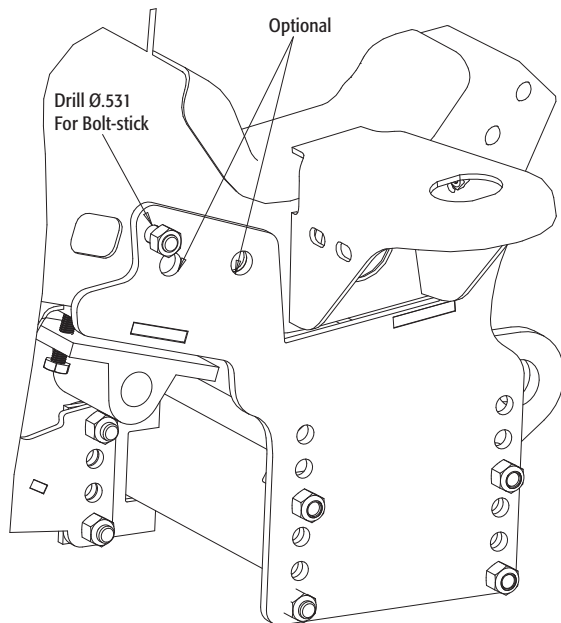

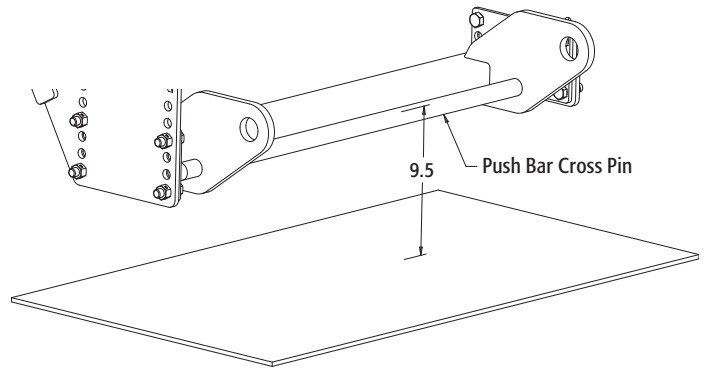

6. Repeat step #3-4 for the DS Side Plate (3).
7. On the side of the frame, Re-use the Steering Gear Box bolt in the existing hole. Ignore the 1/2" hole.
8. Mount the PUSHBAR (1) in place between the two side plates using eight 1/2"-13x1-1/2" BOLTS (13) and eight 1/2"-13 LOCK NUTS (14). The centerline of the Pushbar Crosspin should be approximately 9 1/2" from the ground. The air dam and the bumper splash-guard of the vehicle may need to be altered to accommodate this height. Improper mounting height will result in uneven cutting edge wear.

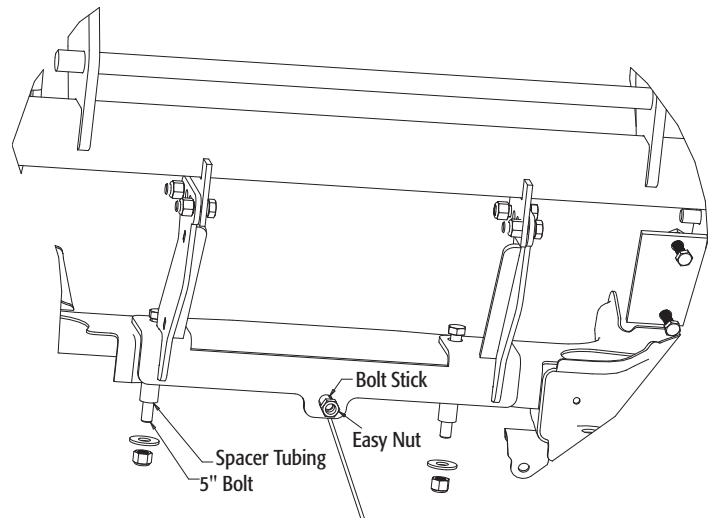

9. Install the Rear Brace (4) onto the push bar with four 1/2" Bolts and Nuts (13&14). Toward the rear of the bracket, secure the Rear Brace onto the cross-frame with two 5 inch bolts. Spacer tubing must be inserted through the inside of the frame with the 5 inch bolts. Secure it onto the cross-frame of the truck with bolts-stick (11) and one nut (15).



10. It may be helpful to route the plow and light control harnesses at this point, prior to bumper re-installation.
11. Torque all fasteners as shown in the chart. Check and re-torque all fasteners after 5 hours of usage to ensure safe plow operation. Ensure all coolant lines and wires are clear of moving or hot components and tie up as necessary.

Recommended Fastener Torque Chart (ft.-lb.)			
Size	 SAE Grade 2	 SAE Grade 5	 SAE Grade 8
1/4-20	6	9	13
5/16-18	11	18	28
3/8-16	19	31	46
3/8-24	24	46	68
7/16-14	30	50	75
1/2-13	45	75	115
9/16-12	66	110	165
5/8-11	93	150	225
3/4-10	150	250	370
7/8-9	150	378	591
1-8	220	583	893
Metric Grade 8.8 (ft.-lb.)			
Size	Torque	Size	Torque
M6	7	M12	60
M8	17	M14	95
M10	35	M16	155
These torque values apply to fasteners except those noted in the instruction.			

WARNING

- DO NOT under any circumstances disable, remove or relocate any sensors or components related to the operation of the air bags.
- Always follow the vehicle manufacturers' recommendations relating to snowplow installation.
- To comply with Federal Regulations and to assure a safe vehicle, the Front Gross Axle Weight Rating (FGAWR), Rear Gross Axle Weight Rating (RGAWR), and the Gross Vehicle Weight Rating (GAWR) must not be exceeded at any time.
- Due to the variety of equipment that can be installed on this vehicle, it is necessary to verify that the Front Gross Axle Weight Rating (FGAWR), Rear Gross Axle Weight Rating (RGAWR), and the Gross Vehicle Weight Rating (GAWR) are not exceeded at any time. This may require weighing the vehicle and adding ballast as necessary. It may also limit payload capacity of the vehicle. It is the operator's responsibility to verify that these ratings are not exceeded.

CAUTION

- Read all instructions prior to assembly
- It is critical that all fasteners be properly torqued for safe plow operation – see chart above.
- Fasteners should be retorqued after 5-8 hours of plow use

FULL ONE-YEAR WARRANTY

Manufacturer will repair, or at manufacturer's discretion will replace any part of this snowplow which proves to be defective in workmanship or material under normal use for a period of one year from the date of delivery to the original purchaser. Any cost incurred in returning the product to the supplier is the responsibility of the consumer.

EXCLUSIONS

Manufacturer shall not be liable for special, incidental, or consequential damages, or for damages resulting from lack of necessary maintenance, from misuse, abuse, acts of God, or alteration of the product. Some states do not allow the exclusion or limitation of incidental or consequential damages, so the above limitation or exclusion may not apply to you.