

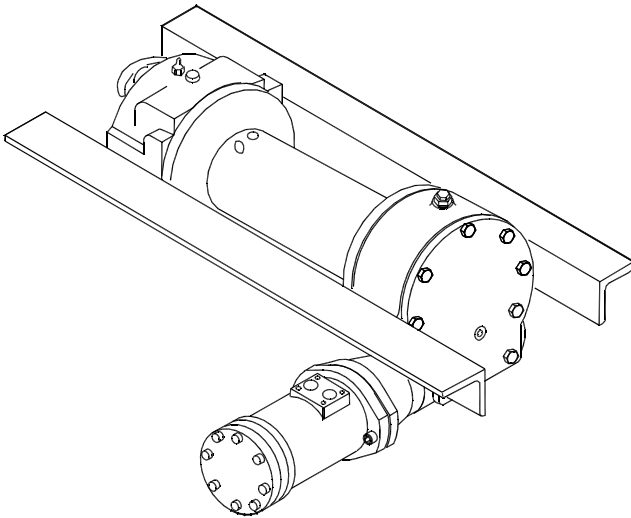

OPERATING, SERVICE AND MAINTENANCE MANUAL



MODEL HD-234 RAM-LOK[®] EQUIPPED INDUSTRIAL LOW-MOUNT WINCHES



**CAUTION: READ AND UNDERSTAND THIS MANUAL BEFORE
INSTALLATION AND OPERATION OF WINCH. SEE WARNINGS!**

TABLE OF CONTENTS

INTRODUCTION	4
WARRANTY INFORMATION	4
SPECIFICATION	4
TECHNIQUES OF OPERATION	5
WARNINGS	6
WINCH MAINTENANCE	6
WINCH MOUNTING	7
CABLE INSTALLATION	7
HYDRAULIC SYSTEMS/PERFORMANCE CHARTS	8
TYPICAL LAYOUT/HYD. SYSTEM DIAGRAM	8
TROUBLE SHOOTING GUIDE	9
INSTRUCTIONS FOR OVERHAUL OF	
RAMSEY MODEL HD-234 RAM-LOK® WINCH	
DIS-ASSEMBLY	10-13
RE-ASSEMBLY	13-16
DIMENSIONAL DRAWING	18-19
PARTS LIST AND PARTS DRAWING	20-23
LIMITED WARRANTY	BACK COVER

RAMSEY WINCH MODEL HD-234 RAM-LOK®

PLEASE READ THIS MANUAL CAREFULLY.

This manual contains useful ideas in obtaining the most efficient operation from your Ramsey Winch, and safety procedures one needs to know before operating a Ramsey Winch.

WARRANTY INFORMATION

Ramsey Winches are designed and built to exacting specifications. Great care and skill go into every winch we make. If the need should arise, warranty procedure is outlined on the back of your self-addressed postage paid warranty card. Please read and fill out the enclosed warranty card and send it to Ramsey Winch Company. If you have any problems with your winch, please follow instructions for prompt service on all warranty claims. Refer to back page for limited warranty.

SPECIFICATIONS: CONFORMS TO SAE J706*

Rated Line Pull (lbs.)	8,000				
(kg)	3,620				
Gear Reduction	34:1				
Weight HD-234	110lbs. (50 kg)				
HYD-234	105 lbs. (48 kg)				
LAYER OF CABLE		1	2	3	4
*Rated line pull lbs.	8,000	8,000	6,700	5,700	5,000
per layer kg	3,620	3,620	3,030	2,610	2,290
**Long Drum ft.	25	25	60	95	140
Cable capacity m	8	8	18	30	43
**Short "Y" Drum ft.	15	15	30	55	75
Cable capacity m	4	4	9	16	22
**Line speed FPM	28	28	34	39	44
MPM	8,6	8,6	10,1	11,7	13,4
* Winch only conforms to SAE J706. For SAE qualification of mounting angles, if applicable, consult Ramsey Engineering					
** These specifications are based on recommended wire rope of 3/8 inch diameter extra improved plow steel or equivalent.					

NOTE: The rated line pulls shown are for the winch only. Consult the wire rope manufacturer for wire rope ratings.

TECHNIQUES OF OPERATION

The best way to get acquainted with how your winch operates is to make test runs before you actually use it. Plan your test in advance. Remember, you hear your winch, as well as see it operate. Get to recognize the sounds of a light steady pull, a heavy pull, and sounds caused by load jerking or shifting. Gain confidence in operating your winch and its use will become second nature with you.

The uneven spooling of cable, while pulling a load, is not a problem, unless there is a cable pileup on one end of drum. If this happens reverse the winch to relieve the load and move your anchor point further to the center of the vehicle. After the job is done you can unspool and rewind for a neat lay of the cable.

When pulling a load where there is even a remote chance of cable failure, place a blanket, jacket or tarpaulin over the cable about six feet behind the hook. This will slow the snap back of a broken cable and could prevent serious injury.

NOTE: The Ramsey level winder is an available accessory for tightly respooling unloaded cable onto the drum.

The Ram-Lok[®] semi-automatic clutch allows rapid unspooling of the cable, from cable drum, for hooking onto the load.

The Manual "T-Handle" clutch is operated as follows:

1. **TO DISENGAGE CLUTCH**, run the winch in the reverse (reel out) direction until the load is off the cable. Pull outward on the T-handle, rotate it counter-clockwise 90° and release. The clutch is now locked out and the cable may be pulled off by hand.
2. **TO ENGAGE CLUTCH**, pull outward on the handle, rotate it clockwise 90° and release. Run the winch in reverse until the shifter knob snaps fully in or until the cable drum starts turning. At this point make sure the shifter knob is all the way in. The plastic plug in top of clutch housing may be removed, for inspection of clutch to assure total engagement. After the clutch is fully engaged, the winch is ready for winching in the cable.

The Air Shifter clutch is operated as follows:

1. **TO DISENGAGE CLUTCH**, run the winch in reverse (reel out) direction until the load is off the cable. Apply 60-125 PSI to inlet port fitting of air cylinder. Run winch in the forward (reel in) direction to disengage clutch.
2. **TO ENGAGE CLUTCH**, remove air pressure from air cylinder. Run the winch in reverse until the cable drum starts turning. The plastic plug in top of clutch housing may be removed, for inspection of clutch to assure total engagement. After the clutch is fully engaged, the winch is ready for winching in the cable.



WARNINGS

CLUTCH MUST BE TOTALLY ENGAGED BEFORE STARTING THE WINCHING OPERATION.

DO NOT DISENGAGE CLUTCH UNDER LOAD.

STAY OUT FROM UNDER AND AWAY FROM RAISED LOADS.

STAND CLEAR OF CABLE WHILE PULLING. DO NOT TRY TO GUIDE CABLE.

DO NOT EXCEED MAXIMUM LINE PULL RATINGS SHOWN IN TABLE.

DO NOT USE WINCH TO LIFT, SUPPORT, OR OTHERWISE TRANSPORT PEOPLE.

A MINIMUM OF 5 WRAPS OF CABLE AROUND THE DRUM BARREL IS NECESSARY TO HOLD THE LOAD. CABLE ANCHOR IS NOT DESIGNED TO HOLD LOAD.

WINCH MAINTENANCE

Adhering to the following maintenance schedule will keep your winch in top condition and performing as it should with a minimum of repair.

A. WEEKLY

1. Check the oil level and maintain it to the oil level plug. If oil is leaking out, determine location and repair.
2. Check the pressure relief plug in top of the gear housing. Be sure that it is in good operating condition so that hot oil gases may escape.
3. Lubricate cable with light oil.

B. MONTHLY

1. Lubricate the various grease fittings located in the cable drum, end bearing, clutch housing, or clutch operating linkage. Any good grade of moly-disulfide containing grease is acceptable.
2. Check the action of the sliding clutch—ensure it is fully engaging and disengaging with the cable drum. To observe if the clutch is fully engaging, remove the plastic plug in top of the housing. If clutch is not fully engaging:
 - Inspect clutch shifter assembly parts, check for damage or excessive wear and replace as necessary.
 - Observe the jaws on both the clutch and cable drum, checking for rounding of the driving faces. If rounding has occurred they should be replaced immediately.
3. Check the winch mounting bolts. If any are missing, replace them and securely tighten any that are loose. Make sure to use only SAE grade 5 bolts or better.
4. Check alignment of chain and sprockets and adjust as required to minimize wear.
5. Inspect the cable. If the cable has become frayed with broken strands, replace immediately.

C. ANNUALLY

1. Drain the oil from the winch annually or more often if winch is used frequently.
2. Fill the winch to the oil level plug with clean kerosene. Run the winch a few minutes with no load in the reel in direction. Drain the kerosene from the winch.
3. **Refill the winch to the oil level plug with Phillips SMP 80W-90, Mobil HD 80W-90, Shell Spirax HD 80W-90, or CITGO MP 80W-90 gear oil only.**
4. Inspect frame and surrounding structure for cracks or deformation.
5. Gear wear can be estimated by rocking the drum back and forth and if necessary drain oil and remove cover for closer inspection.

WINCH MOUNTING

It is most important that this winch be mounted securely so that the three major sections (clutch housing end, cable drum, and gear housing end) are properly aligned. All standard model HD-234 series winches are furnished with recommended mounting angles. Angle size is 1/4 x 2-1/2 x 2-1/2 x 36" long high strength steel angle.

CABLE INSTALLATION

1. Unwind cable by rolling it out along the ground to prevent kinking. Securely wrap end of cable, opposite hook, with plastic or similar tape to prevent fraying.
2. Insert the end of cable, opposite hook end, into the 7/16" dia. hole in drum barrel. Secure cable to drum barrel, using setscrew furnished with winch. **TIGHTEN SETSCREW SECURELY.**
3. Carefully run winch in the "reel-in" direction. Keeping tension on end of cable, spool all the cable onto the cable drum, taking care to form neatly wrapped layers.

HYDRAULIC SYSTEMS

Refer to performance charts, below, to properly match your hydraulic system to the HD-234 winch performance. The charts consist of:

1. Line pull (lbs.) first layer vs. working pressure (PSI). STATIC (solid line) refers to hoisting a suspended load from rest; DYNAMIC (dashed line) refers to maintaining the motion of a moving load.
2. Line speed, first layer (FPM) vs. gallons per minute (GPM).

Performance based on a motor displacement of 3.6 cubic inches with 15 GPM maximum flow rate.

HD-234 PERFORMANCE 8,000 LB. DUTY RATING - 34:1 GEAR RATIO

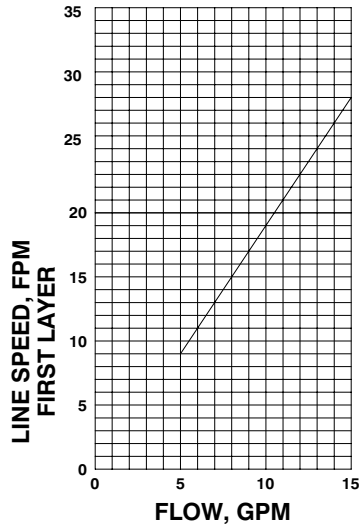
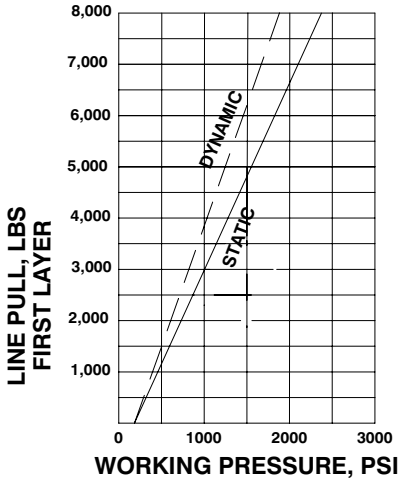

TYPICAL LAYOUT

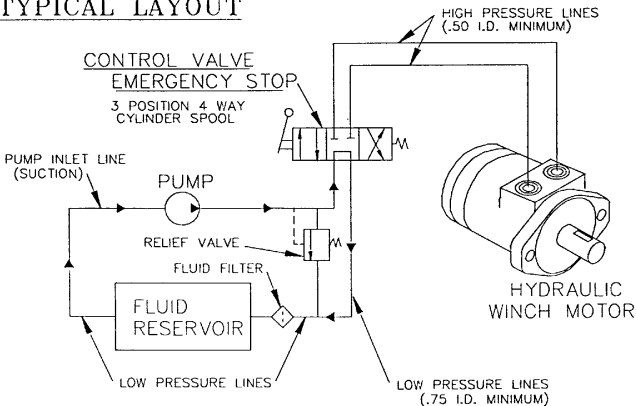

Troubleshooting Guide

CONDITION	POSSIBLE CAUSE	CORRECTION
CLUTCH INOPERATIVE OR BINDS UP	<ol style="list-style-type: none"> 1. Dry or rusted shaft. 2. Bent yoke or linkage. 3. Clutch jaws are in contact. 	<ol style="list-style-type: none"> 1. Clean and lubricate 2. Replace yoke or shaft assembly. 3. See <i>Techniques of Operation</i> .
OIL LEAKS FROM HOUSING	<ol style="list-style-type: none"> 1. Seal damaged or worn. 2. Too much oil. 3. Damaged gasket. 	<ol style="list-style-type: none"> 1. Replace seal. 2. Drain excess oil. Refer to <i>Techniques of Operation</i> . 3. Replace gasket.
WINCH RUNS TOO SLOW	<ol style="list-style-type: none"> 1. Hydraulic motor worn out. 2. Low flow rate. 	<ol style="list-style-type: none"> 1. Replace motor. 2. Check flow rate. Refer to Hydraulic Systems flow chart.
CABLE BIRDNESTS WHEN CLUTCH IS DISENGAGED	<ol style="list-style-type: none"> 1. Drag brake disc worn. 	<ol style="list-style-type: none"> 1. Replace discs.
HYDRAULIC FLUID LEAKS OUT HOLE IN MOTOR ADAPTER	<ol style="list-style-type: none"> 1. Hydraulic motor shaft seal damaged. 	<ol style="list-style-type: none"> 1. Replace seal.

INSTRUCTIONS FOR OVERHAUL OF RAMSEY MODEL HD-234 RAM-LOK®

DIS-ASSEMBLY

1. Drain oil from gear housing by removing plug (item #38) from bottom of gear housing. Remove plugs (items #35 & #37) from top of gear housing. Remove mounting angles from winch by removing hardware shown.

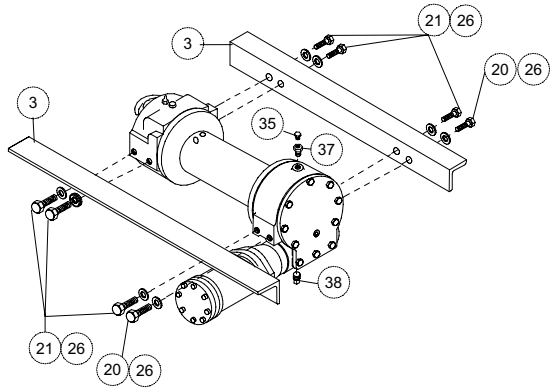

2. Remove clutch housing (item #10) and clutch (item #5) from winch assembly.

Remove two keys (item #32) from keyways. A screwdriver can be used, at notch, to aid in the removal of keys. Once keys have been removed, drum (item #7) and thrust washer (item #42) can be removed from drum shaft.

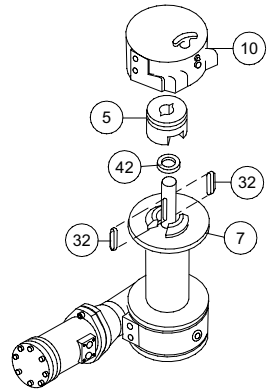

- Remove key (item #12) from worm shaft.
Remove bearing cap (item #4) and gasket (item #30) by unscrewing four capscrews (item #18)
Remove seal (item #42) from bearing cap and press new seal into place.
Drag brake disc (item #29) and spring should be examined and replaced if necessary.

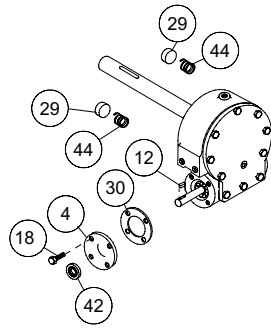

- Remove motor (item #36) and coupling (item #28) from adapter (item #2) by unscrewing two capscrews (item #23).
Remove key (item #12) from worm shaft. Unscrew four capscrews (item #22) and remove adapter from gear housing. Replace adapter seal (item #42) and gasket (item #30).

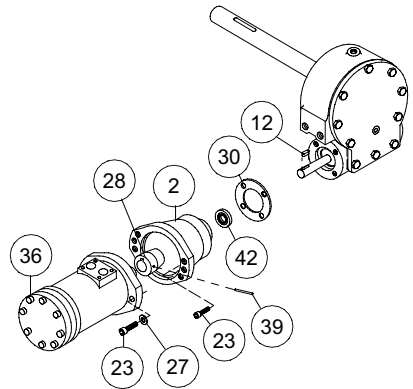

- Remove bearing cap (item #4) from gear housing by unscrewing four capscrews (item #18). Remove worm (item #14) and bearings (item #15) from gear housing. Use soft hammer to gently tap input end of worm and drive worm and bearing from gear housing. Once worm has been removed from housing, bearing can be pressed from end of worm.

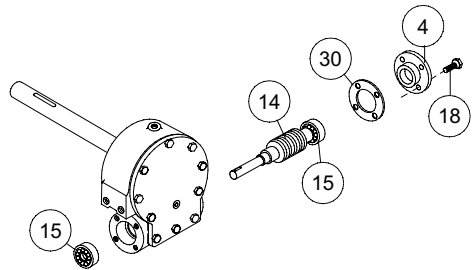

Check for signs of wear or damage to worm (item #14) and bearing (item #15).
Replace if necessary.

6. Remove gear housing cover (item #6) from gear housing (item #11) by unscrewing capscrews (item #18). Thread two of the capscrews into the two tapped holes of cover and tighten. This will pull the cover loose from the gear housing.

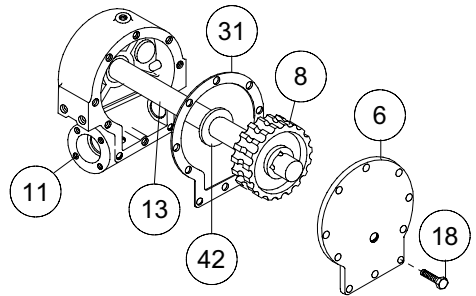

Remove cover gasket (item #31) and pull shaft (item #13), with gear attached, and thrust washer (item #42) from gear housing.

7. Check for signs of wear on gear teeth. If replacement of gear is necessary, replace as follows:

- Press gear (item #8) from shaft (item #13).
- Examine shaft keys and keyways. If distortion of keys and/or keyways is evident, shaft and keys should be replaced.
- Use a soft hammer to gently tap keys (item #33) into keyways. Press gear (item #8) over shaft and keys. Gear must be centered over keys.

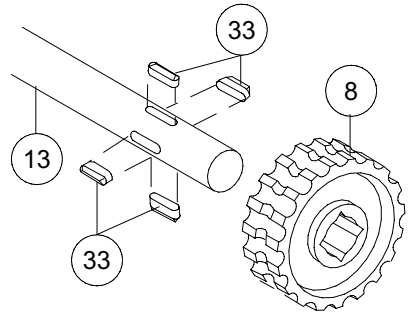

8. Remove seal (item #43) from back of gear housing (item #11). Press bushing (item #17) from gear housing. Press new bushing and seal back into place.

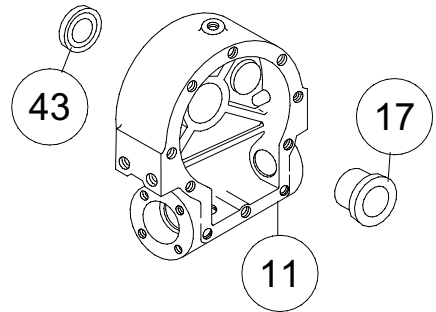

9. Check drum bushings (item #16) for signs of wear. Replace if necessary by pressing old bushings from drum. Press new ones into place.

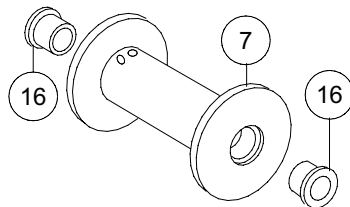

10. Examine shifter assembly (item #1) for damage to yoke. Yoke should be firmly attached to shaft yet able to swivel freely around shaft. Replace if necessary by removing pin (item #34) from handle (item #9).

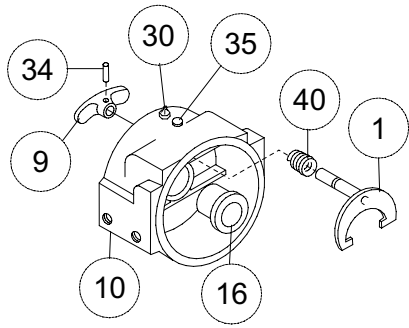

Remove rubber plug (item #35) from housing. Unscrew setscrew enough to allow shifter assembly to be removed from housing. Install new shifter assembly (item #1) by placing end of shaft, opposite yoke, through spring (item #40) and into housing (item #10). Attach handle (item #9) to shaft using roll pin (item #34). Tighten setscrew, in housing, enough to allow shifter assembly to operate properly. Replace rubber plug (item #35).

11. Check cover bushing (item #16) for signs of wear. If necessary remove old bushing and press bushing into place.

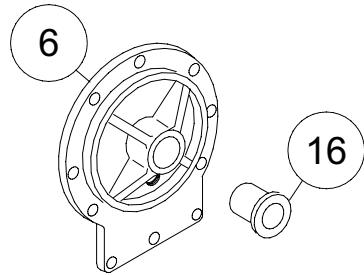

RE-ASSEMBLY

12. Apply grease to end of shaft, opposite gear. Apply grease to bushing in gear housing (item #11). Place greased end of shaft through thrust washer (item #42) and bushing in gear housing (item #11). Place gasket (item #31) onto gear housing cover (item #6). Apply grease to gear end of shaft and cover bearing. Place cover onto shaft and secure to housing with ten capscrews (item #18). **Tighten capscrews to 8 ft-lbs. (10.8 Nm) each.**

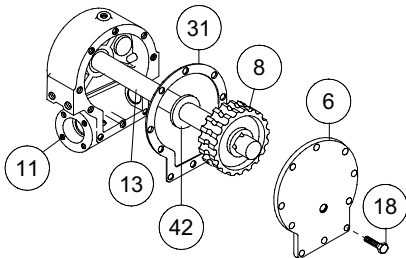

13. Press bearing (item #15) onto worm (item #14) Note: Be sure that thick shoulder of bearing's outer race (side with manufacturer's name and part number) is out, away from worm threads. Press bearing and worm into gear

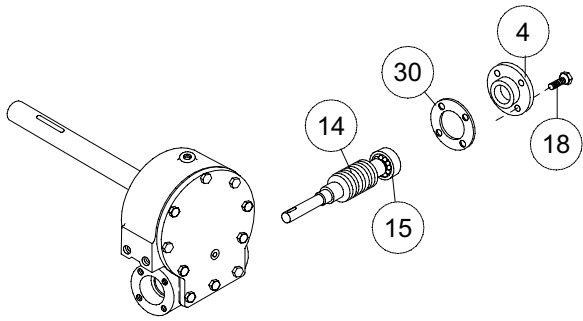

housing. Slip gasket (item #30) onto bearing cap (item #4). Use four cap-screws (item #18) to secure cap to gear housing. **Tighten capscrews to 8 ft-lbs. (10.8 Nm) each.**

14. Press bearing (item #15) onto worm and into gear housing. Note: Be sure that thick shoulder of bearing's outer race (side with manufacturer's name and part number) is out, away from worm threads. Attach bearing cap (item #4) to gear housing. Use four capscrews (item #18) to secure. **Tighten capscrews to 8 ft-lbs. (10.8 Nm) each.** Tap key (item #12) into key-way.

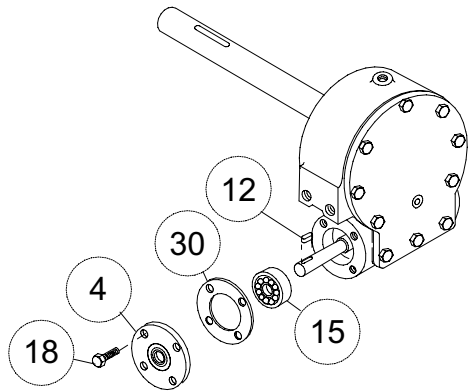

15. Press bearing (item #15) onto worm and into housing. Note: Be sure that thick shoulder of bearing's outer race (side with manufacturer's name and part number) is out, away from worm threads. Place gasket (item #30) onto adapter (item #2). Attach adapter to gear housing using four cap-screws (item #22). **Tighten cap-screws to 12 ft-lbs. (16.3 Nm) each.** Insert key (item #12) into keyway of worm shaft. Slide tapered end of coupling (item #28) over end of worm shaft. Be sure roll pin (item #39) is in coupling.

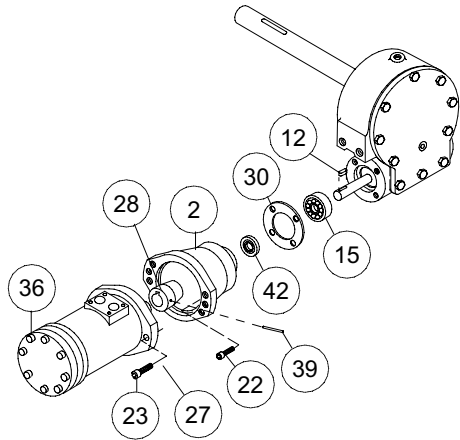

Place motor shaft, with key in keyway, into coupling. Secure motor (item #36) to adapter, using two cap-screws (item #23) and lockwashers. **Tighten cap-screws to 75 ft-lbs. (102 Nm) each.**

16. Place winch with gear housing cover down on work bench. Drum shaft should be in vertical position. Slide thrust washer (item #46) over drum shaft and slide downward until washer rests on gear housing. Set springs (item #44) into pockets of gear housing with drag brakes (item #29) on top of springs. Slide drum assembly (item #7) onto drum shaft with drum jaws upward.

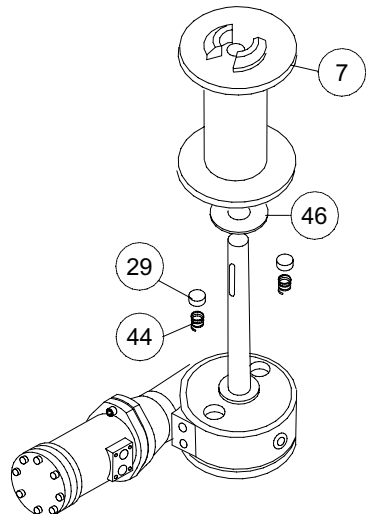

17. Place thrust washer (item #47) over end of drum shaft and slide downward until space rests on drum. Press drum downward to compress springs in gear housing.

Insert keys (item #32) into keyways with sharp edge of keys pointing outward and notched end of keys upward. A rubber or brass mallet will be needed to gently tap keys into position.

Apply grease to keys and end of shaft. Place jaw clutch (item #5) over end of shaft and slide jaw clutch over keys.

Set clutch housing (item #10) over end of drum shaft. Pull jaw clutch (item #5) upward, toward clutch housing, enough to allow yoke, in clutch housing, to fit properly in groove around jaw clutch.

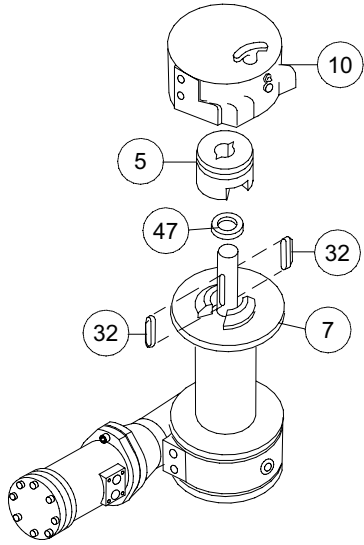

18. Attach two mounting angles (item #2) using six capscrews (item #21) with lockwashers and two capscrews (item #20). Tighten capscrews to 34 ft-lbs. (46 Nm) each. Insert plug (item #38) into bottom of gear housing. Permatex may be applied to threads to help prevent leakage.

Pour 3/4 pint of **Phillips SMP 80W-90, Mobil HD 80W-90, Shell Spirax HD 80W-90, or CITGO MP 80W-90 gear oil only** into housing through hole in top of housing. Insert relief fitting (item #35) into reducer (item #37). Reducer should then be placed into hole on top of gear housing. tighten fitting and reducer securely.

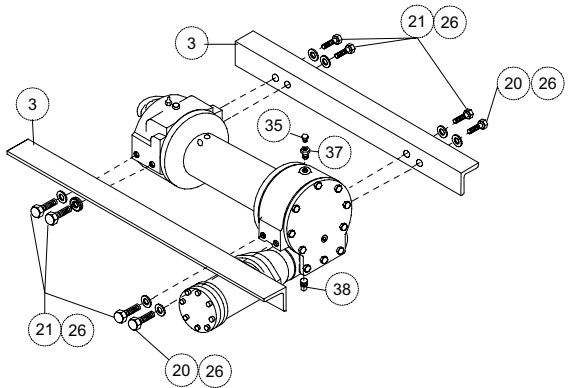

NOTES

WINCH MODEL	A INCHES MM	B INCHES MM	C INCHES MM	D INCHES MM
HD-234	7.78 197.6	11.31 287.3	8.94 227.0	13.12 333.3
HYD-234	5.28 134.1	6.31 160.3	11.44 290.5	8.12 206.3

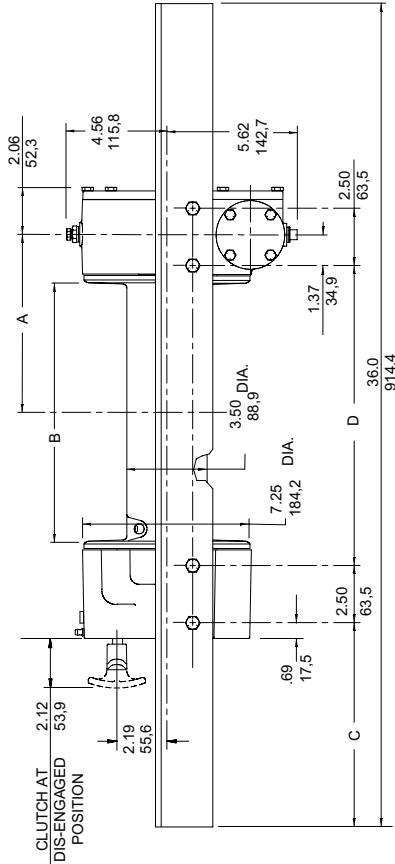
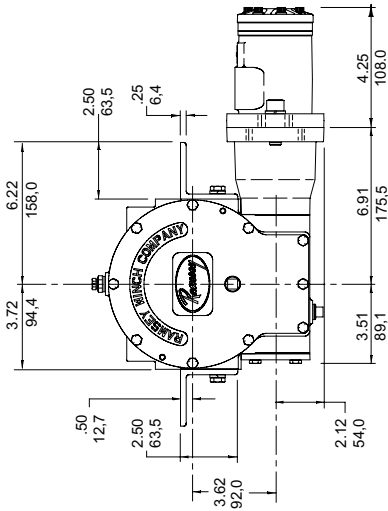

DIMENSIONS SHOWN ARE INCHES OVER MILLIMETERS

Model HD-234 Ram-Lok® Manual Shift

INSTALLATION INSTRUCTIONS FOR TAGS 434385 AND 434386

CLUTCH
ENGAGED

The clutch is spring loaded for engagement when air pressure is removed from air shifter. Verify air shifter control valve lever position for engaged position. This tag, 434385, must be mounted as near as possible to air shifter control lever in the ENGAGED position.

CLUTCH
DISENGAGED

The clutch is dis-engaged by applying 60-125 psi air pressure to air shifter. Verify air shifter control valve lever position for dis-engaged position. This tag, 434386, must be mounted as near as possible to air shifter control lever in the DIS-ENGAGED position.

WINCH MODEL	A		B		C		D	
	INCHES	MM	INCHES	MM	INCHES	MM	INCHES	MM
HD-234	7.78	11.31	8.94	13.12	227.0	333.3	6.22	158.0
HYD-234	5.28	6.31	11.44	8.12	290.5	206.3	3.72	94.4

QUICK DISCONNECT FITTING
FOR 1/4 O.D. TUBING
(60 PSI MIN./125 PSI MAX.)
FOR DISENGAGING CLUTCH,
(CLUTCH IS SPRING ENGAGED)

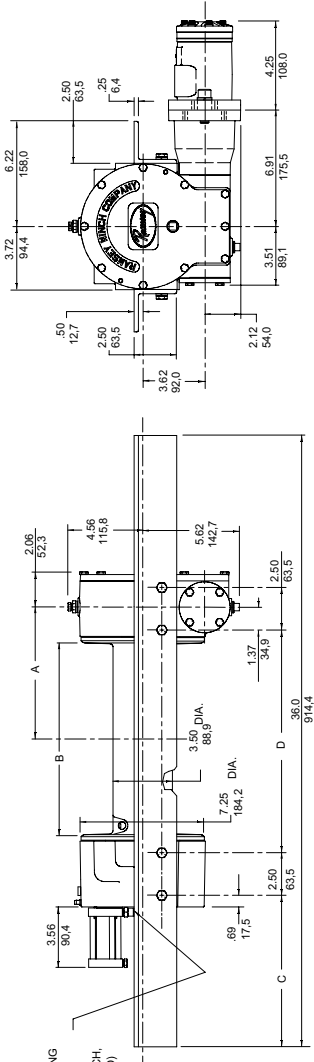

DIMENSIONS SHOWN ARE INCHES OVER MILLIMETERS

Model HD-234 Ram-Lok® Air Shift

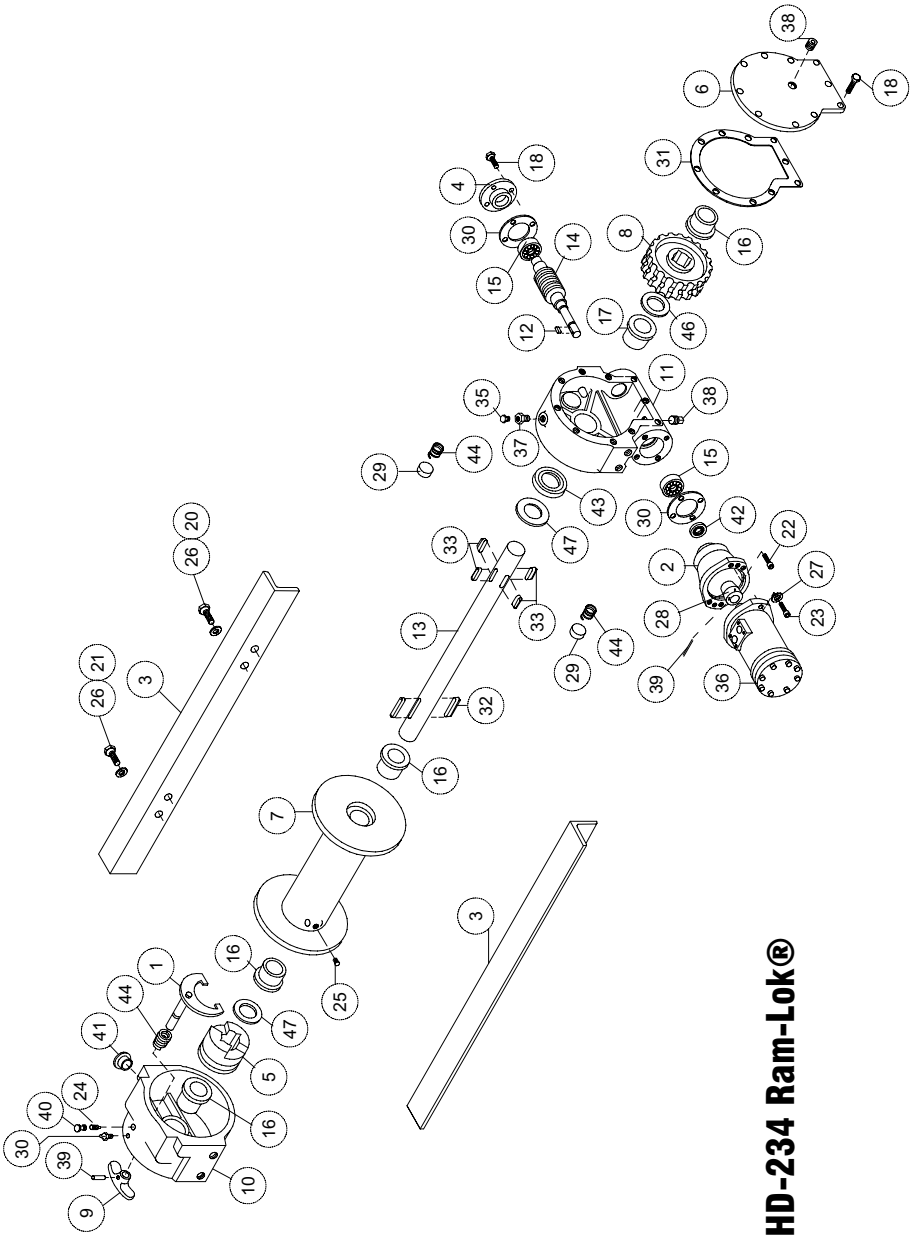

Model HD-234 Ram-Lok®

PARTS LIST MODEL HD-234 RAMLOK

Item No.	Qty.	Parts No.	Description	Item No.	Qty.	Parts No.	Description
1	1	276028	ASSEMBLY - SHIFTER	24	1	416030	SETScrew 1/4-20NC X 3/8 SOC HD LESS
2	1	300057	ADAPTER	25	1	416059	SETScrew 3/8-16UNC X .50 LG HX SOC. HEADLESS CUP PT.
3	2	302809	ANGLE - "STD."	26	8	418177	LOCKWASHER 3/8 MED SECT Z/P
	2	302810	ANGLE - "Y"	27	2	418218	LOCKWASHER 1/2 MED SECT
4	1	316083	BEARING CAP	28	1	431008	COUPLING
5	1	324160	CLUTCH - JAW	29	2	438014	DISC - BRAKE
6	1	328134	COVER	30	2	442184	GASKET
7	1	332007	DRUM - "Y"	31	1	442205	GASKET
	1	332105	DRUM - "STD."	32	2	450006	KEY - BARTH
8	1	334183	GEAR - R.H.	33	4	450016	KEY - BARTH
9	1	336010	HANDLE	34	1	456001	FITTING - LUBE
10	1	338208	HOUSING - CLUTCH	35	1	456008	FITTING - RELIEF
11	1	338273	HOUSING - GEAR	36	1	458111	MOTOR - HYDRAULIC 3.6 CU. IN.
12	1	342027	KEY	37	1	468002	REDUCER
13	1	357479	SHAFT - DRUM "STD."	38	2	468011	PLUG - PIPE
	1	357481	SHAFT - DRUM "Y"	39	2	470033	PIN - SPIROL
14	1	368203	WORM - R.H.	40	1	472012	PLUG - RUBBER
15	2	402002	BEARING - BALL	41	1	472013	PLUG - PLASTIC
16	4	412003	BUSHING	42	1	486009	SEAL - OIL
17	1	412045	BUSHING	43	1	486017	SEAL - OIL
18	14	414045	CAPSCREW 1/4-20UNC X 7/8 LG HX HD GR5 ZIP	44	2	494002	SPRING
				45	1	494053	SPRING
20	2	414279	CAPSCREW 3/8-16NC X 3/4 LG HX HD GR5	46	1	518014	WASHER - THRUST
21	6	414282	CAPSCREW 3/8-16UNC X 1.25 LG HX HD GR5	47	2	518015	WASHER - THRUST
22	4	414842	CAPSCREW 1/4-20UNC X 1.75 LG SOC HD ZIP LOK-WEL				
23	2	414952	CAPSCREW 1/2-13UNC X 1/50 LG HX SOC HD ZIP				

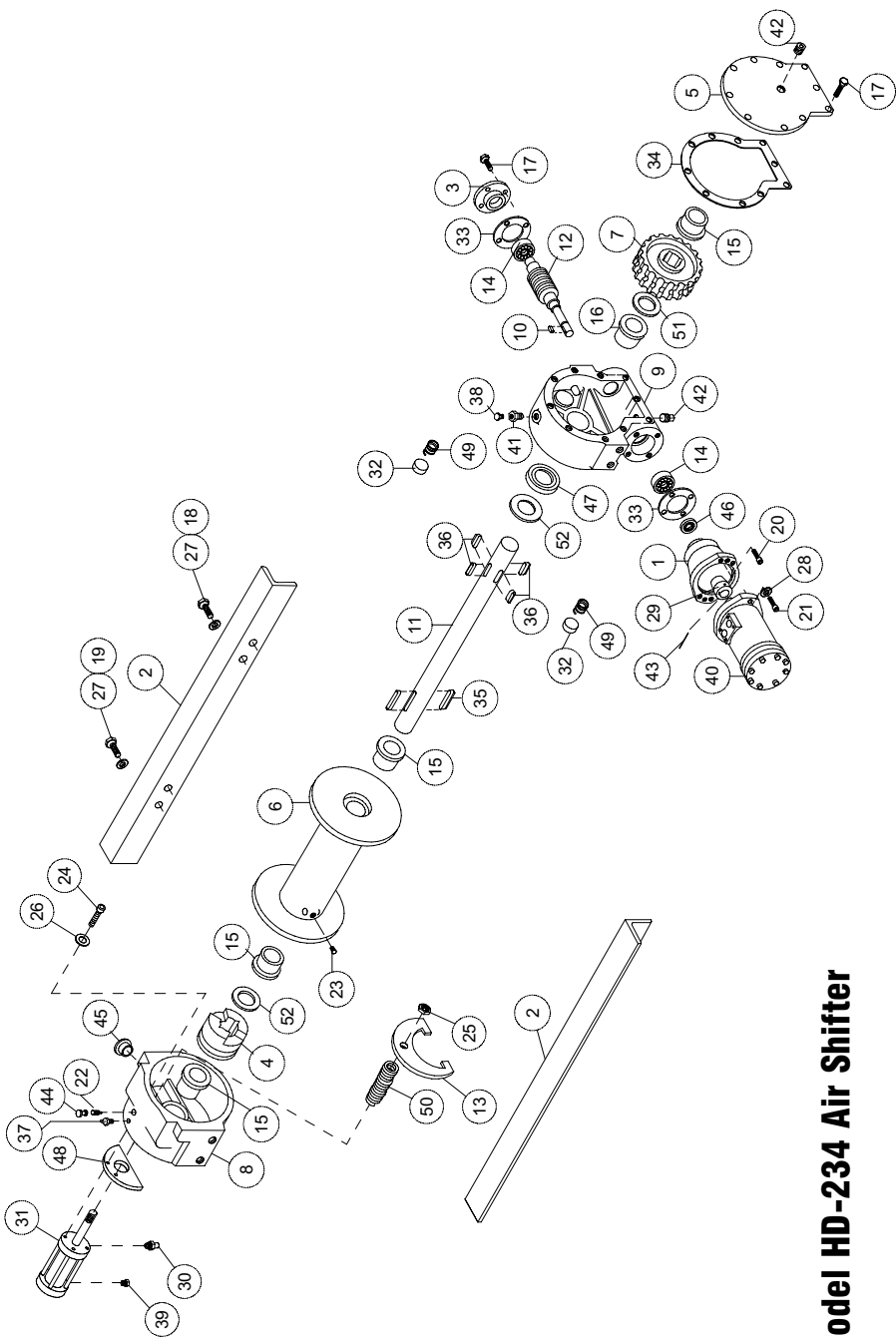

Model HD-234 Air Shifter

PARTS LIST MODEL HD-234 AIR SHIFT

Item No.	Qty.	Parts No.	Description	Item No.	Qty.	Parts No.	Description
1	1	300057	ADAPTER	26	4	418136	LOCKWASHER #6 MED
2	2	302809	ANGLE - "STD."	27	8	418177	LOCKWASHER 3/8 MED SECT Z/P
3	2	302810	ANGLE - "Y"	28	2	418218	LOCKWASHER 1/2 MED SECT
4	1	316083	BEARING CAP	29	1	431008	COUPLING
5	1	324160	CLUTCH - JAW	30	1	432043	FITTING-QUICK DISC
6	1	328134	COVER	31	1	433021	AIR CYLINDER
7	1	332007	DRUM - "Y"	32	2	438014	DISC - BRAKE
8	1	332105	DRUM - "STD."	33	2	442184	GASKET
9	1	334183	GEAR - R.H.	34	1	442205	GASKET
10	1	338309	HOUSING - CLUTCH	35	2	450006	KEY - BARTH
11	1	338273	HOUSING - GEAR	36	4	450016	KEY - BARTH
12	1	342027	KEY	37	1	456001	FITTING - LUBE
13	1	357479	SHAFT - DRUM "STD."	38	1	456008	FITTING - RELIEF
14	1	357481	SHAFT - DRUM "Y"	39	1	456038	FITTING - BREATHER
15	1	368203	WORM - R.H.	40	1	458111	MOTOR - HYDRAULIC 3.6 CU. IN.
16	1	370058	YOKE	41	1	468002	REDUCER
17	2	402002	BEARING - BALL	42	2	468011	PLUG - PIPE
18	4	412003	BUSHING	43	2	470033	PIN - SPIROL
19	1	412045	BUSHING	44	1	472012	PLUG - RUBBER
20	14	414045	CAPSCREW 1/4-20UNC X 7/8 LG HX HD GR5 Z/P	45	1	472013	PLUG - PLASTIC
21	6	414279	CAPSCREW 3/8-16NC X 3/4 LG HX HD GR5	46	1	486009	SEAL - OIL
22	6	414282	CAPSCREW 3/8-16UNC X 1.25 LG HX HD GR5	47	1	486017	SEAL - OIL
23	4	414842	CAPSCREW 1/4-20UNC X 1.75 LG SOC HD Z/P LOK-WEL	48	1	488012	SHIM
24	2	414952	CAPSCREW 1/2-13UNC X 1/50 LG HX SOC HD Z/P	49	2	494002	SPRING
25	1	416030	SETScrew 1/4-20NC X 3/8 SOC HD LESS	50	1	494053	SPRING
26	1	416059	SETScrew 3/8-16UNC X .50 LG HX SOC. HDLESS CUP PT.	51	1	518014	WASHER - THRUST
27	4	416198	SCREW #6-32NC X 1 LG HX SOCHD Z/P	52	2	518015	WASHER - THRUST
28	1	418044	NUT 3/8-16NC				

LIMITED WARRANTY

RAMSEY WINCH warrants each new RAMSEY winch to be free from defects in material and workmanship for a period of one (1) year from date of purchase.

The obligation under this warranty, statutory or otherwise, is limited to the replacement or repair at the Manufacturer's factory, or at a point designated by the Manufacturer, of such part that shall appear to the Manufacturer, upon inspection of such part, to have been defective in material or workmanship.

This warranty does not obligate RAMSEY WINCH to bear the cost of labor or transportation charges in connection with the replacement or repair of defective parts, nor shall it apply to a product upon which repair or alterations have been made, unless authorized by Manufacturer, or for equipment misused, neglected or which has not been installed correctly.

RAMSEY WINCH shall in no event be liable for special or consequential damages. RAMSEY WINCH makes no warranty in respect to accessories such as being subject to the warranties of their respective manufacturers.

RAMSEY WINCH, whose policy is one of continuous improvement, reserves the right to improve its products through changes in design or materials as it may deem desirable without being obligated to incorporate such changes in products of prior manufacture.

If field service at the request of the Buyer is rendered and the fault is found not to be with RAMSEY WINCH's product, the Buyer shall pay the time and expense to the field representative. Bills for service, labor or other expenses that have been incurred by the Buyer without approval or authorization by RAMSEY WINCH will not be accepted

See warranty card for details.



RAMSEY WINCH COMPANY

P.O. Box 581510 • Tulsa, Oklahoma 74158-1510 USA

Phone: (918) 438-2760 • Fax: (918) 438-6688

www.ramsey.com