

CM MOUNT KIT 16061010 UNIVERSAL

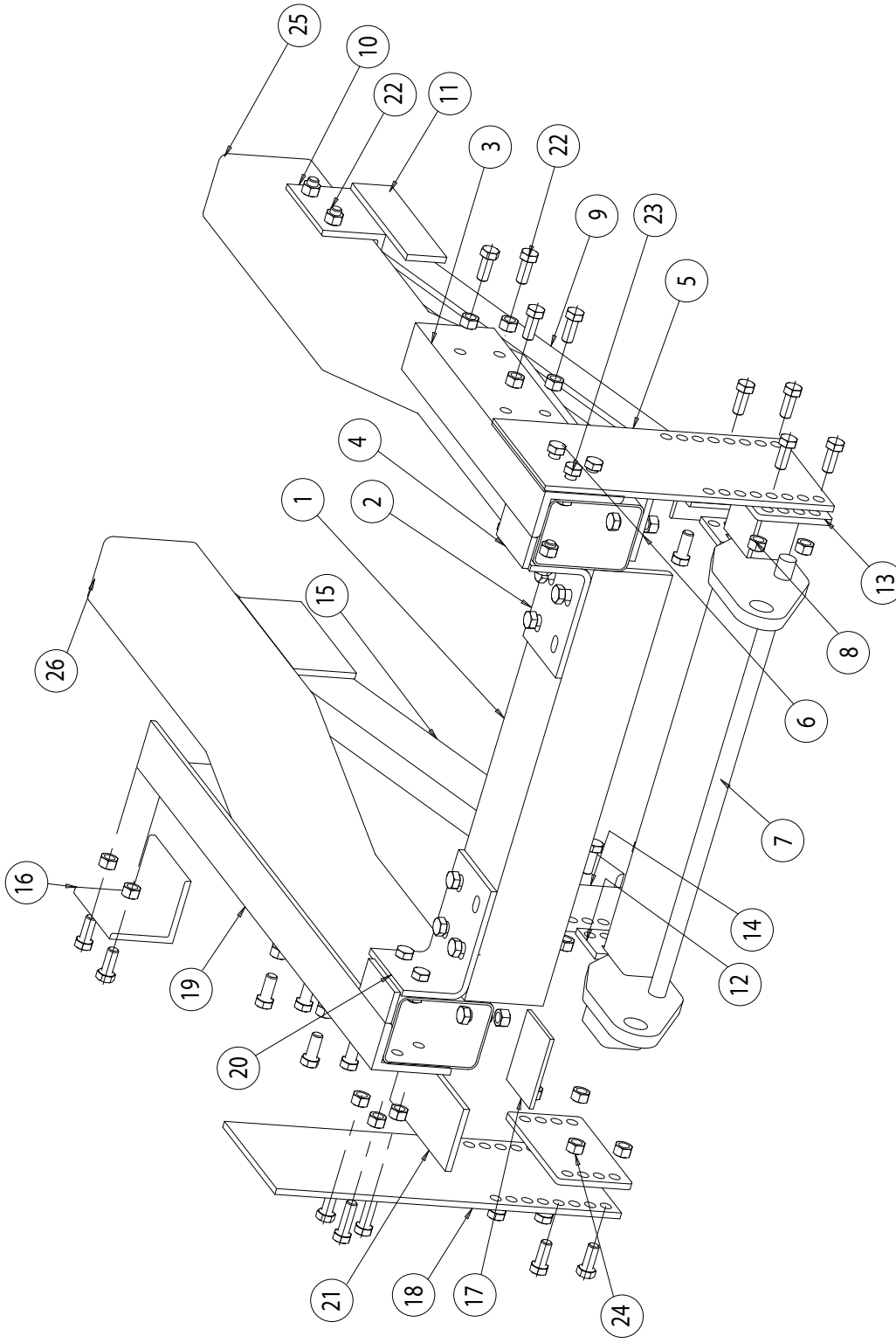

SnowDogg™ Snowplow

TRUCK MOUNT INSTALLATION MANUAL



Parts List

ITEM	PART NO.	QTY.	DESCRIPTION
1	3014879-CUT	1	Cut-Angle, Front Cross Angle
2	3014885-CUT	1	Cut-Angle, Front Bracket
3	3014887-CUT	1	Cut-Angle, Upper Stiffener
4	3014878-CUT3	2	Cut-Gusset, Front Side Plates - Angle
5	3014877-CUT	1	Cut-Sideplate, Uni-Muni Mount
6	3014878-CUT1	1	Cut-Gusset, Front Sideplates - Angle
7	16061011-CUT	1	Pushbar, Universal Muni
8	3014875-CUT	1	Cut-Gusset, Pushbar
9	3014884-CUT	1	Cut-Armature, Bracket Angle 36"
10	3014886-CUT	1	Cut-Angle, Frame Bracket
11	3014878-CUT2	1	Cut-Gusset, Rear Sideplates - Angle
12	3014876	2	Support, Center W4 Bolt Holes
13	3014873	2	Plate, Push Mount

ITEM	PART NO.	QTY.	DESCRIPTION
14	3014880	2	Bracket, Angle w/4 Holes
15	3014884	1	Armature, Bracket Angle 36"
16	3014886	1	Angle, Frame Bracket
17	3014875	1	Gusset, Pushbar
18	3014877	1	Sideplate, Uni-Muni Mount
19	3014887	1	Angle, Upper Stiffener
20	3014885	1	Angle, Front Bracket
21	3014878	2	Gusset, Front Sideplates - Angle
22	FCS06301150Z01	38	Screw, HH Cap 5/8-11 x 1.5 Gr. 5 ZN
23	FCS063011200	6	Screw, Hex Cap 5/8-11 x 2 Gr. 5 ZN
24	FNH063011053	44	Nut, 5/8-11 ZN
25	-	1	Truck, Frame
26	-	1	Truck, Frame

INSTRUCTIONS

1. Remove the bumper and bumper fasteners. Set aside for later reinstallation. Remove the tow hooks if your vehicle is equipped with them.
2. Place the **Upper Angle Stiffener** (3) onto the DS frame and cut excess material from the angle as needed. Position the **Stiffener** flush [or extend further if you have room for the bumper] to the end of the frame, drill four holes $\text{\O} .656$ " through the **Stiffener** and the frame. Secure the **Stiffener** with four 5/8" fasteners (22 & 24). Cut the **Gusset** (4) to fit onto the frame. Tack-weld the gusset to the two **Angles** (2 & 3) together. On the bottom of the frame, cut gusset (6) to fit flush to the bottom frame and tack-weld to the side-plates. Drill and install two 5/8 fasteners.

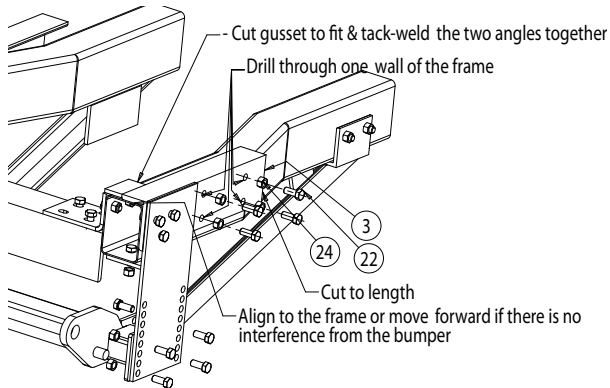

3. Repeat for the PS frame.
4. Position the DS & PS **Side-plates** (5) onto the frame. Tack-weld or Clamp onto the frame temporary so we can position the Push-bar in place.
5. Cut the **Push-bar** (7) to length evenly both PS and DS. Position the **Push-bar** (7) as shown. Tack-weld the Push-bar onto the **Push Mount Plate** (13) eight spots (it will be welded later when the Lift Frame unit is fit nicely together). Cut gusset (8) and tack weld to the pushbar.

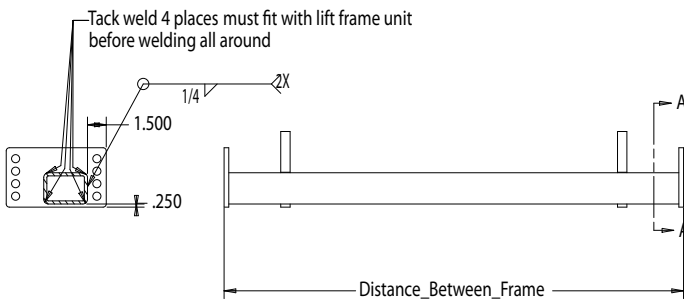

6. Secure the newly-welded **Push-bar** (7) onto the two **Side-plates** (5) with eight 5/8-11 fasteners. Adjust the height of the Push-bar to approximately 11" from the level-ground. This is a flexible position where the eight fasteners determined the final position of the plow relative to the floor. Cut the side plates (5) shorter as needed.

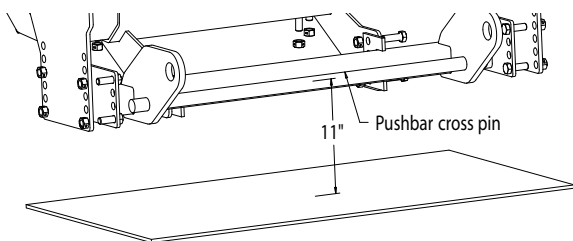

7. Measure the Lift Frame distance from the bumper. It should be about 7.0 inches from the bumper. It may be necessary to un-clamp the two **Side-plates** (5) to move it back and forth to keep a safe clearance from the bumper. **Do not** position the Side-plates too far inward so it can cause the lift frame to be mounted too close to the bumper.

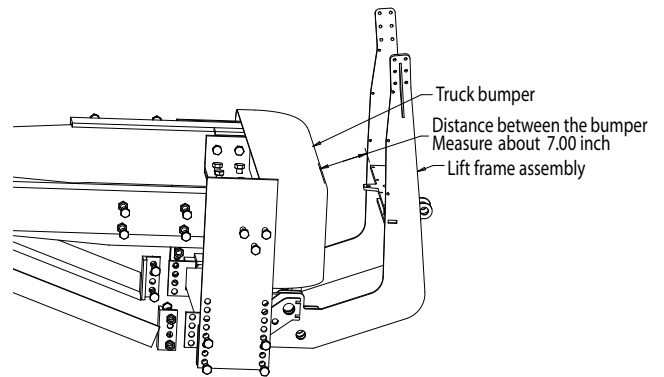

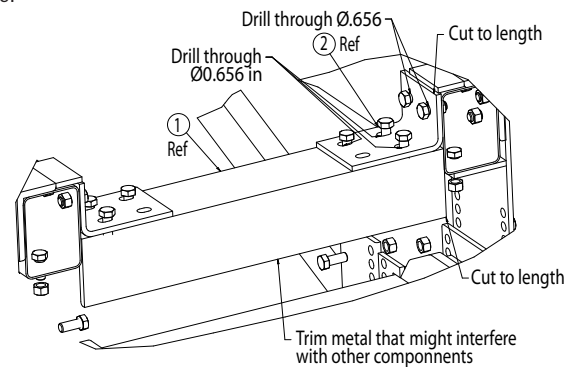

8. Reinforce the truck frame by adding a **Front Cross Angle** (1). Measure **Front Cross Angle** (1) and cut them to the correct length between PS and DS frames of the truck. Position the **Front Bracket Angle** (2) toward the inside of the frame and to the top of the frame. Drill three holes $\text{\O} .656$ " on the **Front Cross Angle** both PS and DS. Also, drill two holes $\text{\O} .656$ " through the frame.

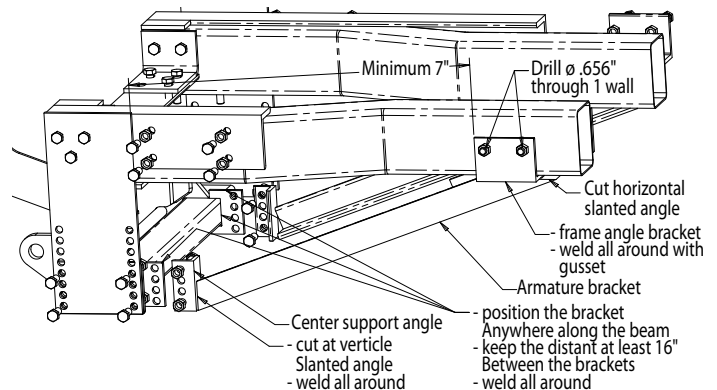

9. Install the Rear Armature assembly with the following instruction. Position the **Frame Bracket Angle** (10) at a convenience place at least 7" away from the edge of the **Side-plate** (5). Cut the **Armature Bracket** (9) to length. It is necessary to cut the **Armature Bracket** (9) at a slanted angle to fit with the **Frame Bracket Angle** (10). Cut the **Gusset material** (11) and weld as needed. Position the front end of the **Armature Bracket** (9) toward the **Center Support Angle** (12) and cut it at a slanted angle to match the vertical position shown. Weld all around as needed.



10. Repeat step number 9 for PS **Armature Bracket** (15).
11. If every thing fits well, weld all components that use tack welded earlier.
12. It may be helpful to route the plow and light control harnesses at this point, prior to bumper re-installation.
13. Torque all fasteners as shown in the chart. Check and re-torque all fasteners after 5 hours of usage to ensure safe plow operation. Ensure all coolant lines and wires are clear of the moving or hot components and tie up as necessary.

Recommended Fastener Torque Chart (ft.-lb.)			
Size	 SAE Grade 2	 SAE Grade 5	 SAE Grade 8
1/4-20	6	9	13
5/16-18	11	18	28
3/8-16	19	31	46
3/8-24	24	46	68
7/16-14	30	50	75
1/2-13	45	75	115
9/16-12	66	110	165
5/8-11	93	150	225
3/4-10	150	250	370
7/8-9	150	378	591
1-8	220	583	893
Metric Grade 8.8 (ft.-lb.)			
Size	Torque	Size	Torque
M6	7	M12	60
M8	17	M14	95
M10	35	M16	155
These torque values apply to fasteners except those noted in the instruction.			

WARNING

- DO NOT under any circumstances disable, remove or relocate any sensors or components related to the operation of the air bags.
- Always follow the vehicle manufacturers' recommendations relating to snowplow installation.
- To comply with Federal Regulations and to assure a safe vehicle, the Front Gross Axle Weight Rating (FGAWR), Rear Gross Axle Weight Rating (RGAWR), and the Gross Vehicle Weight Rating (GAWR) must not be exceeded at any time.
- Due to the variety of equipment that can be installed on this vehicle, it is necessary to verify that the Front Gross Axle Weight Rating (FGAWR), Rear Gross Axle Weight Rating (RGAWR), and the Gross Vehicle Weight Rating (GAWR) are not exceeded at any time. This may require weighing the vehicle and adding ballast as necessary. It may also limit payload capacity of the vehicle. It is the operator's responsibility to verify that these ratings are not exceeded.

CAUTION

- Read all instructions prior to assembly
- It is critical that all fasteners be properly torqued for safe plow operation – see chart above.
- Fasteners should be retorqued after 5-8 hours of plow use

FULL ONE-YEAR WARRANTY

Manufacturer will repair, or at manufacturer's discretion will replace any part of this snowplow which proves to be defective in workmanship or material under normal use for a period of one year from the date of delivery to the original purchaser. Any cost incurred in returning the product to the supplier is the responsibility of the consumer.

EXCLUSIONS

Manufacturer shall not be liable for special, incidental, or consequential damages, or for damages resulting from lack of necessary maintenance, from misuse, abuse, acts of God, or alteration of the product. Some states do not allow the exclusion or limitation of incidental or consequential damages, so the above limitation or exclusion may not apply to you.