

HD/EX MOUNT KIT

16062500

GM 3500HD '91-'02



SnowDogg™ Snowplow

TRUCK MOUNT INSTALLATION MANUAL

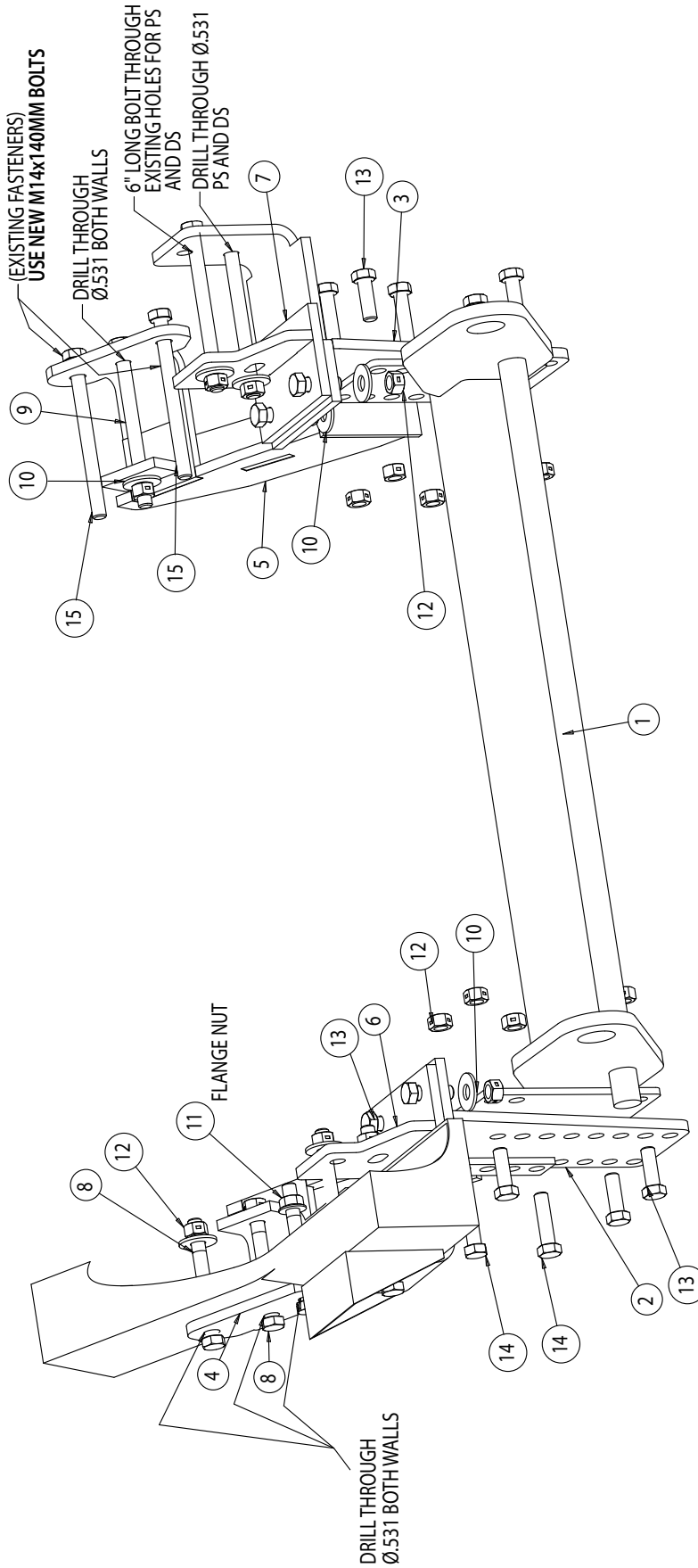



Parts List

ITEM	PART NO.	QTY.	DESCRIPTION
1	16062503	1	Push Bar, HD/EX GM 3500HD 91-02
2	16062504	1	Side Plate, Weldment PS 3500HD
3	16062505	1	Side Plate, Weldment DS 3500HD
4	16062507	1	Armature, Weldment PS
5	16062508	1	Armature, Weldment DS
6	16062506	1	Bracket, Side Flange Weldment PS
7	16062509	1	Bracket, Side Plate Flange Weldment DS
8	3012583	3	Screw, HHC - 1/2-13 x 4.5 Gr. 5, ZN
9	3011524	5	Screw, Hex HD - 1/2-13 x 6, Gr. 8, ZN
10	FWF050138014	10	Washer, Flat, .500 x 1.38 x .14, ZN
11	3001523	1	Nut, HX FLING - 1/2-13 SST
12	3002397	21	Locknut, Hex 1/2-13, ZN, Gr. 8
13	3006202	10	Screw, Hex HD - 1/2-13 x 1-1/2 Gr. 8, ZN
14	3001384	4	Screw, Hex Cap 1/2-13 x 2" Gr. 5, ZN
15	3021720	2	M14 x 140mm Long

INSTRUCTIONS

- 1.** Remove the front bumper, bumper fasteners, and skid plate. Set aside for later reinstallation.
- 2.** Remove the tow hooks (if your vehicle option is equipped with them).
- 3.** Hold the PS Bracket (2) up against the passenger side frame rail, aligning with the existing holes on the side of the frame. Attach the Side Plate Bracket (6) to the frame where it loops around the leaf spring. Secure the Bracket using two 6 inch bolts (9), two ½-13 x 1.5 bolts (13), four flat washers (10), and four locknuts (12).

**Notes.* The 6 inch bolts will go through the holes at an angle across the frame. It is also necessary to drill Ø.531 diameter for the second 6 inch bolt hole.*
- 4.** Repeat step 3 above for DS Bracket.
- 5.** Mount the Pushbar (1) in place between the two side plates using six ½-13x1-1/2 bolts (13), two ½-13x2 bolts (14) and eight locknuts (12). The centerline of the pushbar crosspin should be approximately 8¾" from the ground. Improper mounting height will result in uneven cutting edge wear.
- 6.** Install the PS Armature Rear Brace Member (4) to the Pushbar (1). Secure it using two ½-13x2 inch bolts (14) from the side-plates. Using the PS Armature as a template, drill three Ø.531 diameter holes through both side of the frame. Secure the newly-drilled holes with three ½-13x4.5 bolts (8), one flat washer (10), two locknuts (12), and one flange nut (11).
- 7.** On the Driver Side, Remove the existing fasteners from the power steering box. Install the DS Armature Rear Brace Member (5) to the Pushbar (1). Secure it using two ½-13x2 inch bolts (14) from the side-plates. In the rear end, secure the Armature with the M14 x 140mm fasteners. Using the Armature as a template, drill the bottom-center hole with Ø.531 diameter clearance. Secure it with one 6 inch bolt (9) and one locknut.
- 8.** Torque all fasteners as shown in the chart. Check and re-torque all fasteners after 5 hours of usage to ensure safe plow operation.
- 9.** It may be helpful to route the plow and light control harnesses at this point, prior to bumper reinstallation.
- 10.** Reinstall the bumper/air dam assembly and skid plate. The bumper/air dam and skid plate may need to be altered or omitted for reinstallation.

Recommended Fastener Torque Chart (ft.-lb.)			
Size	 SAE Grade 2	 SAE Grade 5	 SAE Grade 8
1/4-20	6	9	13
5/16-18	11	18	28
3/8-16	19	31	46
3/8-24	24	46	68
7/16-14	30	50	75
1/2-13	45	75	115
9/16-12	66	110	165
5/8-11	93	150	225
3/4-10	150	250	370
7/8-9	150	378	591
1-8	220	583	893

Metric Grade 8.8 (ft.-lb.)			
Size	Torque	Size	Torque
M6	7	M12	60
M8	17	M14	95
M10	35	M16	155

These torque values apply to fasteners except those noted in the instruction.

WARNING

- DO NOT under any circumstances disable, remove or relocate any sensors or components related to the operation of the air bags.
- Always follow the vehicle manufacturers' recommendations relating to snowplow installation.
- To comply with Federal Regulations and to assure a safe vehicle, the Front Gross Axle Weight Rating (FGAWR), Rear Gross Axle Weight Rating (RGAWR), and the Gross Vehicle Weight Rating (GAWR) must not be exceeded at any time.
- Due to the variety of equipment that can be installed on this vehicle, it is necessary to verify that the Front Gross Axle Weight Rating (FGAWR), Rear Gross Axle Weight Rating (RGAWR), and the Gross Vehicle Weight Rating (GAWR) are not exceeded at any time. This may require weighing the vehicle and adding ballast as necessary. It may also limit payload capacity of the vehicle. It is the operator's responsibility to verify that these ratings are not exceeded.

CAUTION

- Read all instructions prior to assembly
- It is critical that all fasteners be properly torqued for safe plow operation – see chart above.
- Fasteners should be retorqued after 5-8 hours of plow use

FULL ONE-YEAR WARRANTY

Manufacturer will repair, or at manufacturer's discretion will replace any part of this snowplow which proves to be defective in workmanship or material under normal use for a period of one year from the date of delivery to the original purchaser. Any cost incurred in returning the product to the supplier is the responsibility of the consumer.

EXCLUSIONS

Manufacturer shall not be liable for special, incidental, or consequential damages, or for damages resulting from lack of necessary maintenance, from misuse, abuse, acts of God, or alteration of the product. Some states do not allow the exclusion or limitation of incidental or consequential damages, so the above limitation or exclusion may not apply to you.