

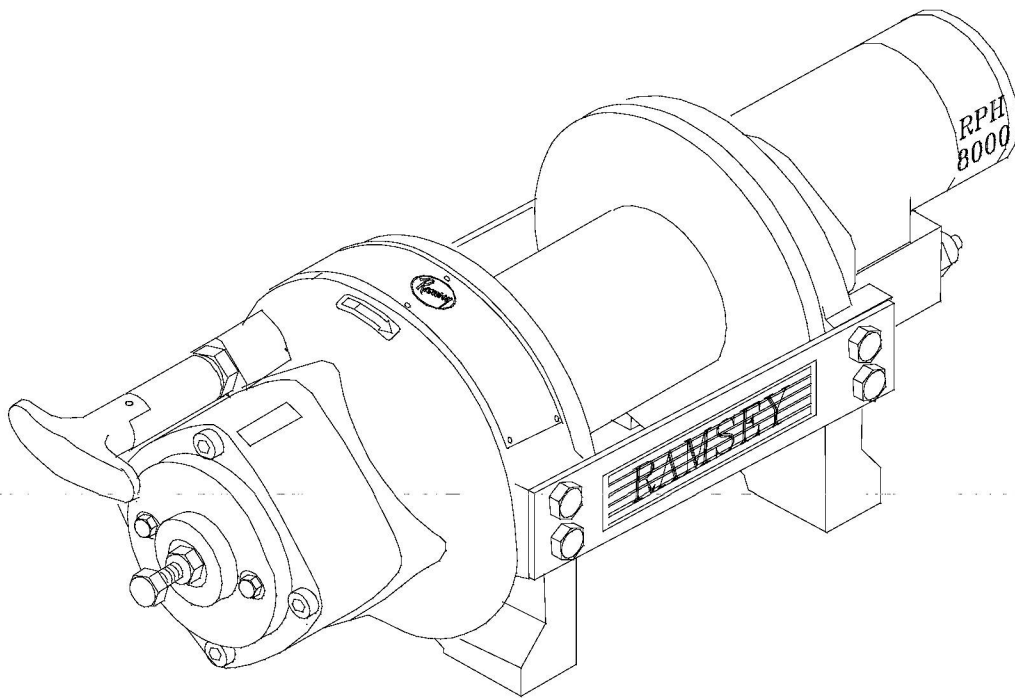

OPERATING, SERVICE AND MAINTENANCE MANUAL



MODEL RPH 8000 PLANETARY WINCH



CAUTION: READ AND UNDERSTAND THIS MANUAL BEFORE INSTALLATION AND OPERATION OF WINCH. SEE WARNINGS!

TABLE OF CONTENTS

INTRODUCTIONS.....	1
WARRANTY INFORMATION.....	1
SPECIFICATIONS.....	1
WARNINGS.....	1
WINCH MOUNTING.....	2
CABLE INSTALLATION.....	3
HYDRAULIC SYSTEM REQUIREMENTS.....	4
PERFORMANCE CHARTS.....	4
OPERATIONS.....	5
MANUAL CLUTCH SHIFTER.....	5
AIR CYLINDER CLUTCH SHIFTER.....	5
MAINTENANCE.....	5
TROUBLE SHOOTING GUIDE.....	6
BRAKE ADJUSTMENT.....	7
INSTRUCTIONS FOR OVERHAUL.....	8-13
DIMENSIONAL DRAWINGS	
RPH 8,000 WITH MANUAL CLUTCH SHIFTER.....	14
RPH 8,000 WITH AIR CYLINDER CLUTCH SHIFTER.....	15
PARTS LIST AND PARTS DRAWINGS	
RPH 8,000 WITH MANUAL CLUTCH SHIFTER.....	16-17
RPH 8,000 WITH MANUAL CLUTCH SHIFTER AND CLUTCH ENGAGEMENT INDICATOR LIGHT.....	18-19
RPH 8,000 WITH AIR CYLINDER CLUTCH SHIFTER.....	20-21
RPH 8,000 WITH BLOCKED CLUTCH.....	22-23
LIMITED WARRANTY.....	24

RAMSEY HYDRAULIC PLANETARY WINCH MODEL RPH-8000

PLEASE READ THIS MANUAL CAREFULLY

This manual contains useful ideas in obtaining the most efficient operation from your Ramsey Winch, and safety procedures one needs to know before operating a Ramsey Winch. Do not operate this winch until you have carefully read and understand the "WARNING" and "OPERATION" sections of this manual.

WARRANTY INFORMATION

Ramsey Winches are designed and built to exacting specifications. Great care and skill go into every winch we make. If the need should arise, warranty procedure is outlined on the back of your self-addressed postage paid warranty card. Please read and fill out the enclosed warranty card and send it to Ramsey Winch Company. If you have any problems with our winch, please follow instructions for prompt service on all warranty claims. Refer to back page for limited warranty.

SPECIFICATIONS*

Rated Line Pull (lbs.).....		8,000 lbs.				
Gear Reduction.....		5.1:1				
Weight (without cable) RPH 8000-Y.....		85 lbs.				
RPH 8000-S.....		30 lbs.				
LAYER OF CABLE		1	2	3	4	5
*Rated line pull per layer	Lbs. Kg.	8,000 3,620	6,800 3,080	5,900 2,670	5,200 2,350	4,700 2,120
Cable capacity per layer						
RPH-8000-S (STD DRUM)	Ft.	25	55	90	130	170
	M.	7	16	27	39	51
RPH-8000-Y (*Y DRUM)	Ft.	15	35	60	85	115
	M.	4	10	18	25	34
Line speed (at 15 GPM)	FPM	50	58	67	76	84
	MPM	15.2	17.6	20.3	23.1	25.5
* These specifications are based on recommended cable of 3/8" (10mm) galvanized aircraft cable, or EIPS cable and a 14.9 Cu. in./Rev. motor.						

NOTE: The rated line pulls shown are for the winch only. Consult the wire rope manufacturer for wire rope ratings.

WARNINGS:

CLUTCH MUST BE FULLY ENGAGED BEFORE STARTING THE WINCH.

DO NOT DISENGAGE CLUTCH UNDER LOAD.

DO NOT LEAVE CLUTCH ENGAGED WHEN WINCH IS NOT IN USE.

STAY OUT FROM UNDER AND AWAY FROM RAISED LOADS.

STAND CLEAR OF CABLE WHILE PULLING. DO NOT TRY TO GUIDE CABLE.

DO NOT EXCEED MAXIMUM LINE PULL RATINGS SHOWN IN TABLE.

DO NOT USE WINCH TO LIFT, SUPPORT, OR OTHERWISE TRANSPORT PERSONNEL.

A MINIMUM OF 5 WRAPS OF CABLE AROUND THE DRUM BARREL IS NECESSARY TO HOLD THE LOAD. CABLE CLAMP (SETScrew) IS NOT DESIGNED TO HOLD LOAD.

IN CAR CARRIER APPLICATIONS, AFTER PULLING VEHICLE ON CARRIER, BE SURE TO SECURE VEHICLE TO CARRIER BED. DO NOT MAINTAIN LOAD ON WINCH CABLE WHILE TRANSPORTING VEHICLE. DO NOT USE WINCH AS A TIE DOWN

WHEN PULLING A HEAVY LOAD PLACE A BLANKET, JACKET, OR TARPULIN OVER THE CABLE FIVE OR SIX FEET FROM THE HOOK.

AVOID CONDITIONS WHERE LOAD SHIFTS OR JERKS OCCUR, AS THEY MAY INDICATE A DANGEROUS SITUATION

WINCH MOUNTING

ESSENTIAL MOUNTING INSTRUCTIONS TO MAINTAIN ALIGNMENT OF PLANETARY WINCH COMPONENTS

It is most important that this winch be mounted securely so that the three major sections (the motor end, the cable drum and the gear housing end) are properly aligned. Excessive bushing wear and difficulty in freespooling are usually symptoms of misalignment.

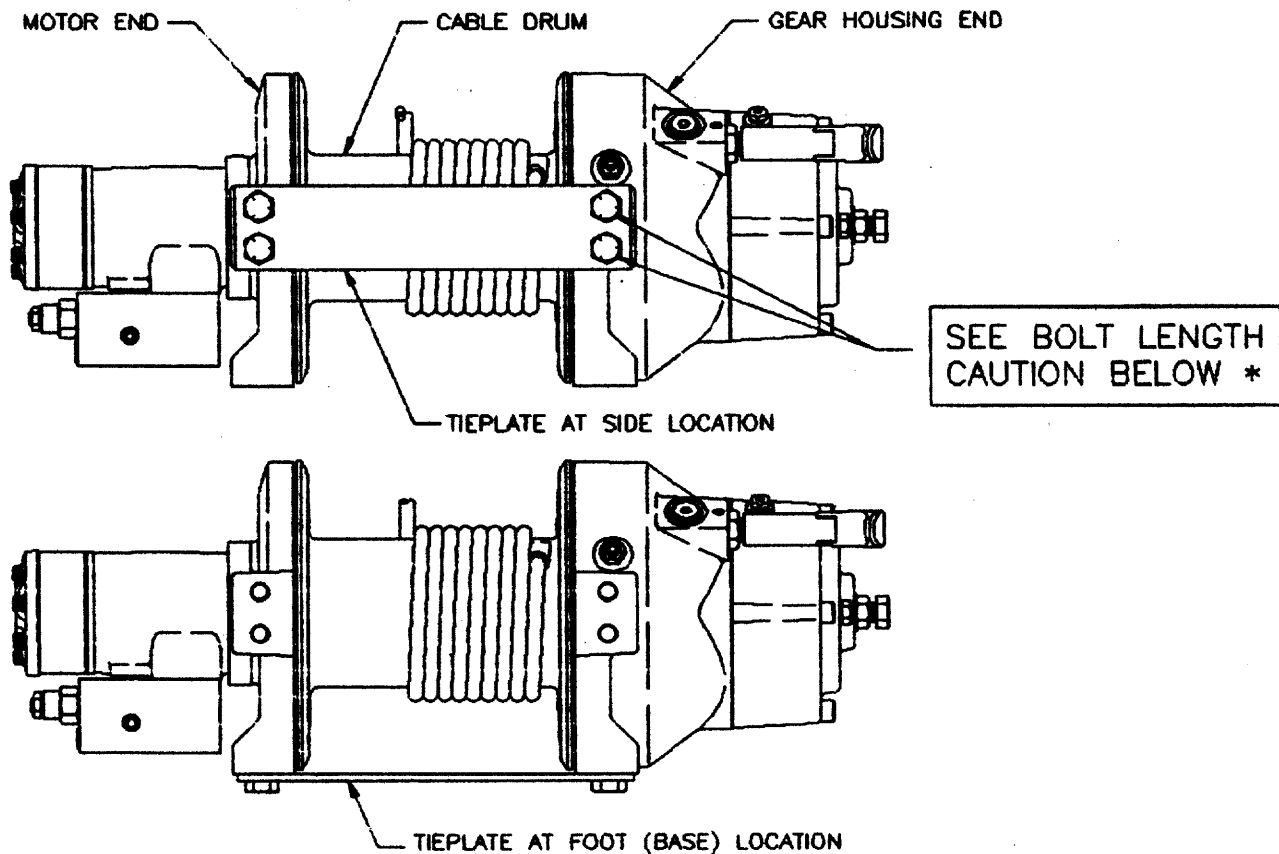

In the as-installed condition, if the winch is mid mounted then at least one tie plate must be attached to the mounting feet at the bottom of the winch to maintain alignment. **NOTE:** If the winch is foot mounted then at least one tie plate must remain mounted at mid point of winch to maintain alignment. It is always desirable to use both tie plates in the final installed configuration.

Angle Mounting Kit, #251006 ("STD." drum) and #251007 ("Y" drum), is recommended for maximum ease in mounting the winch. The angle kit will allow the winch to be mounted in upright or midmount applications and will meet the criteria of serving as a solid and true mounting surface.

When mounting the winch with other than the recommended Ramsey Angle Kit, the mounting hole patterns described on page 14 must be used. The mounting surface must be flat within .015 inch and sufficiently stiff to resist flexing. If a steel plate is used for foot mounting it should be .750 inch thick. For this mounting application eight (8) 1/2-13NC x 1-1/2 Lg. Gr. 5 capscrews with lockwashers will be needed to mount winch. Capscrews should be torqued to 85 ft. lb. (115 Nm.).

NOTE: If angles or a steel plate are used in mounting winch, tie plates provided with winch are to be attached to the remaining mounting pads, whether they be side or foot.

***CAUTION:** If longer bolts (minimum Grade 5) are substituted to mount winch or to mount a roller guide at the side mount pads, bolt length must be such as to allow a maximum of .50 inch thread length engagement in the tapped holes in sides of each end bearing. Refer to page 15. Use of excessive length bolts will damage the winch and prevent free spool of the drum. Torque bolts to 55 ft.lbs. (75 Nm).

CABLE INSTALLATION

A decal on the top of the end bearing indicates the spooling direction of the cable. Also, a letter "A" or "B" is stamped in the end bearing on the brake end indicating rotation. If the decal is damaged or unreadable, contact Customer Service for additional instructions to determine proper direction.

1. Unwind cable by rolling it out along the ground to prevent kinking. Securely wrap end of cable, opposite hook, with plastic or similar tape to prevent fraying.
2. Place taped end of cable into hole in cable drum, as shown below. Use 3/8-16NC x 1/2 lg. Hx. Soc. drive setscrew (part of 234165 "Y" drum ass'y. & 234166 "STD." drum ass'y.) to secure cable to drum.
3. Carefully run winch in the "reel-in" direction. Keeping tension on end of cable, spool all the cable onto the cable drum, taking care to form neatly wrapped layers.

After installing cable, check freespool operation. Disengage clutch and pull on cable at a walking speed. If cable "Birdnests", loosen jam nut (item #27) and turn nylon screw (item #22) clockwise to increase drag on drum. If cable pull is excessive loosen nylon setscrew by turning counterclockwise. Tighten jam nut when proper setting is obtained. **CAUTION: Over-tightening of jam nut may strip nylon setscrew.**

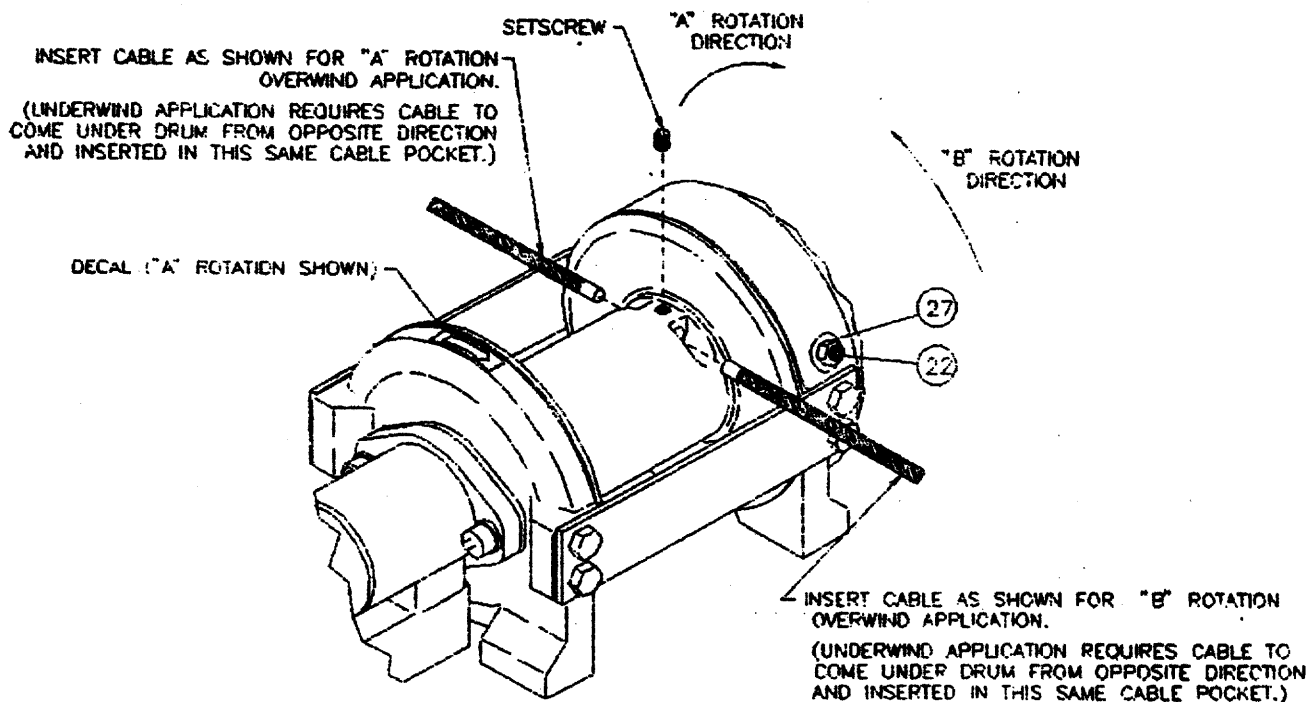

"A" ASSEMBLY
CABLE DRUM ROTATION

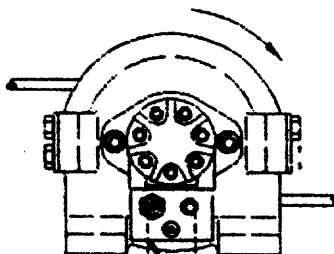

"B" ASSEMBLY
CABLE DRUM ROTATION

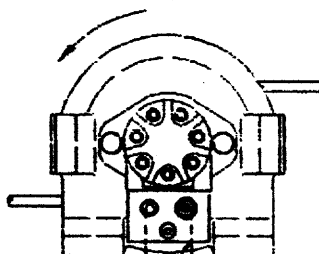

(REEL IN) RAISE INLET

HYDRAULIC SYSTEM REQUIREMENTS

Refer to the performance charts below to properly match your hydraulic system to the winch performance. The charts consist of: (1) line pull (LB) first layer vs. working pressure (PSI). and (2) line speed, first layer (FPM) vs. flow (GPM). STATIC (solid line) refers to hoisting a suspended load from rest; DYNAMIC (dotted line) refers to maintaining the motion of a moving load. A cylinder spool directional control valve is recommended.

SYSTEM REQUIREMENTS:
 2500 PSI RELIEF VALVE SETTING
 15 GPM FLOW RATE*
 10 MICRON NOMINAL FILTRATION
 1000 PSI MAXIMUM BACK PRESSURE

***CAUTION:** DO NOT EXCEED 20 GPM. IF EXCEEDED, MOTOR AND WINCH MAY BE DAMAGED.

TYPICAL LAYOUT

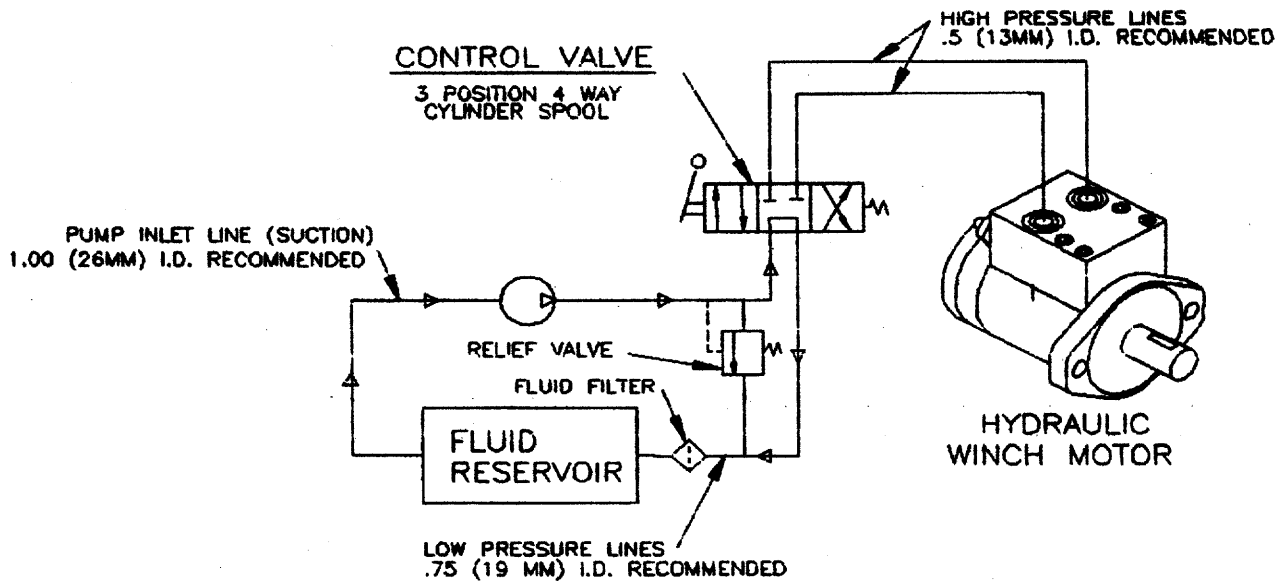

PERFORMANCE CHARTS*

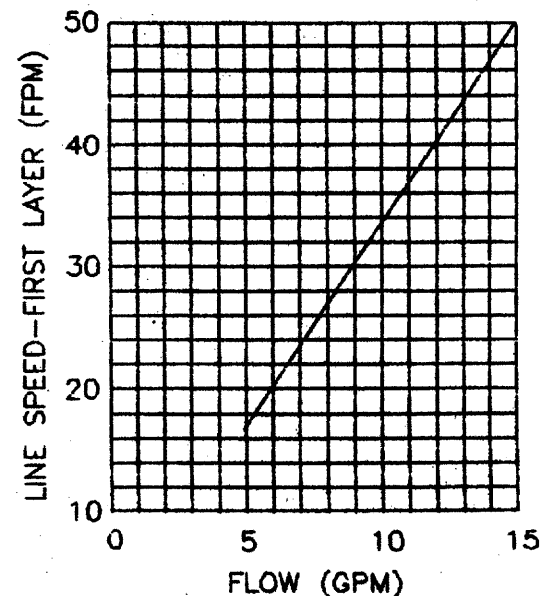
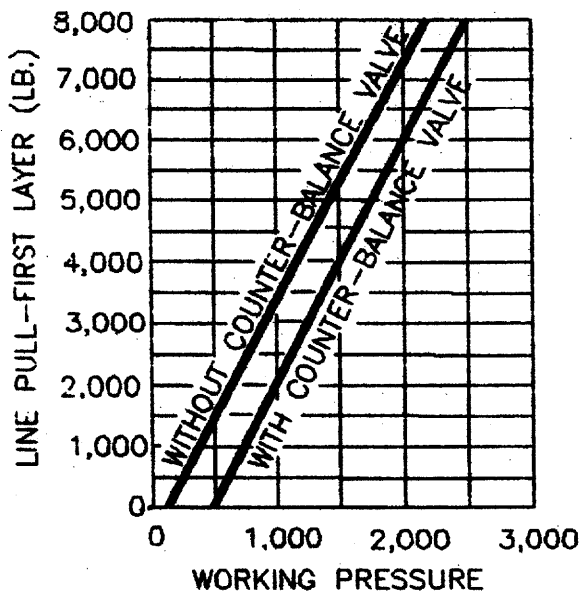

BASED ON 14.9 CU. IN./REV. MOTOR

OPERATION

The best way to get acquainted with how your winch operates is to make test runs before you actually use it. Plan your test in advance. Remember, you hear your winch, as well as see it operate. Get to recognize the sounds of a light steady pull, a heavy pull, and sounds caused by load jerking or shifting. Avoid conditions where load shifts or jerks occur, as they may indicate a dangerous situation.

The uneven spooling of cable, while pulling a load, is not a problem, unless there is a cable pileup on one end of drum. If this happens, reverse the winch to relieve the load and move your anchor point further to the center of the vehicle. After the job is done you can unspool and rewind for a neat lay of the cable.

When pulling a heavy load place a blanket, jacket or tarpaulin over the cable about five or six feet behind the hook. In the event of a broken cable, this will slow the snap back of the cable and could prevent serious injury.

The winch clutch allows rapid unspooling of the cable, from cable drum, for hooking onto the load. The clutch is operated by the clutch shifter lever or air shifter.

WARNING: DO NOT DISENGAGE CLUTCH UNDER LOAD.

MANUAL CLUTCH SHIFTER (Refer to page 14)

TO DISENGAGE CLUTCH: Run the winch in the reverse (reel out) direction until load is off the cable. Pull handle out and rotate 90°. With handle in the "DISENGAGED" position cable may now be free-spooled from drum.

TO ENGAGE CLUTCH: Pull handle out, rotate 90° and release handle. Run the winch in reverse until the clutch handle snaps fully into the "ENGAGED" position. **DO NOT** attempt to pull a load unless the handle is fully at the "ENGAGED" position. If manual shift indicator light is present, the green light is lit when clutch is fully "ENGAGED". **DO NOT** attempt to pull a load unless the green light is lit. To hookup light to the vehicle electrical system refer to the Electrical Schematic on page 15.

AIR CYLINDER CLUTCH SHIFTER (Refer to page 15)

TO DISENGAGE CLUTCH: Run the winch in the reverse (reel out) direction until load is off the cable. Apply air pressure to the .125-27 NPT port: 80 PSI (min.), 150 PSI (max.). **CAUTION: Pressure must not exceed 150 PSI.**

TO ENGAGE CLUTCH: Remove air pressure from the cylinder (a return spring engages the plunger). Run winch in reverse until the clutch engagement indicator light (green light) is lit. **DO NOT** attempt to pull a load unless the green light is lit. To hookup light to the vehicle electrical system refer to the Electrical Schematic on page 15.

MAINTENANCE

1. Inspect the cable for damage and lubricate frequently. If the cable becomes frayed with broken strands, replace immediately. Cable and hook assembly (100' lg. cable) P/N 524118 ("Y" drum) or (150' lg. cable) P/N 524119 ("STD" drum) may be purchased from a Ramsey distributor.
2. Check that the clutch is fully engaging. See OPERATION instructions, above, for the appropriate clutch shifter. FOR MANUAL CLUTCH ONLY: Monthly disengage clutch, put several drops of oil on the shaft and work clutch IN and OUT several times to lubricate inside of clutch cylinder
3. Check brake for drift. Refer to page 7.
4. Check oil level of winch brake housing every month. Remove oil level plug (refer to pg.13). Oil level should be kept up to oil level hole (plus or minus 1/8"). Replace oil annually or more often if winch is used frequently. Use 1/2 pint of Mobilfluid 424, Phillips HG Fluid, Texaco TDH, Shell Oil Co. Donax TD high performance tractor transmission fluid or equivalent, and for quietest operation, add 1/4 fl. oz. of an oil additive (available from the factory).
5. Check to see that drum cable does not overrun (BIRDNEST) when freespooling. Refer to page 3.
6. Replace drum bushings and seals when seals begin to seep grease. Refer to OVERHAUL INSTRUCTIONS, page 8. Add additional lubricant, Mobilith SHC 007, to gears if required.

TROUBLE SHOOTING GUIDE

CONDITIONS	POSSIBLE CAUSE	CORRECTION
DRUM WILL NOT ROTATE AT NO LOAD	Winch not mounted squarely, causing end bearings to bind up drum.	Check mounting. Refer to WINCH MOUNTING page 2.
	Brake damaged.	Inspect and replace brake.
	Gears damaged.	Inspect and replace damaged gears.
DRUM WILL NOT ROTATE UNDER LOAD	Load greater than rated capacity of winch.	Refer to Specifications pg.1 for line pull rating.
	Low hydraulic system pressure.	Check pressure. Refer to HYDRAULIC SYSTEMS performance charts pg. 4.
	Winch not mounted squarely, causing end bearing to bind up drum.	Check mounting. Refer to WINCH MOUNTING pg. 2.
WINCH RUNS TOO SLOW	Low hydraulic system flow rate.	Check flow rate. Refer to HYDRAULIC SYSTEMS flow chart page 4.
	Motor worn out.	Replace motor.
DRUM WILL NOT FREESPOOL	Clutch not disengaged. Check ADJUSTMENT. Refer to page 12.	Check OPERATION. Refer to page 5.
	Winch not mounted squarely, causing end bearings to bind drum.	Check mounting. Refer to WINCH MOUNTING pg. 2
	Side-mount bolts (item #18, Page 17) too long causing binding of ring gear.	Check bolt length. Bolt thread MUST NOT engage threaded holes in sides of end bearing by more than the .50 inch thread depth in the end bearing. Refer to page 15.
OIL LEAKAGE	Damaged brake housing gasket or breather.	Replace gasket. Check for plugged breather. Refer to pgs. 8 & 10.
	Damaged brake hub seal.	Replace seal. Refer to pg. 10.
OIL LEAKAGE FROM BREATHER PLUG	Breather below oil level.	Check oil level.
LOADS DRIFT	Brake needs adjusting.	Adjust brake. Refer to pg. 7.
CABLE BIRDNESTS WHEN CLUTCH IS DISENGAGED	Drag screw improperly adjusted.	Adjust nylon drag screw. Refer to pg. 3.
EXCESSIVE NOISE	Brake torque too high.	Reduce torque. Refer to page 7.
	Hydraulic system flow too high	Check flow rate. Refer to HYDRAULIC SYSTEMS flow chart pg. 4.
	Brake oil level low.	Check oil level, add oil if necessary.
	Drum in bind, winch not mounted squarely.	Check mounting. Refer to WINCH MOUNTING pg. 2
DRUM CHATTERS, in "REEL IN" direction	Low hydraulic system flow.	Check flow rate. Refer to HYDRAULIC SYSTEMS flow chart pg. 4.
	Low hydraulic system relief pressure setting.	Check relief valve setting. Refer to HYDRAULIC SYSTEMS pg. 4.

ADJUSTING THE BRAKE

All parts of the oil-cooled automatic safety brake are bathed in oil. When the brake wears to the point that the load begins to drift, the brake can be adjusted as follows:

1. Loosen the lock nut on the adjusting screw (see drawing on page 10).
2. Increase the brake torque by turning the adjusting screw clockwise. CAUTION: Only 1/4 turn is usually required to adjust the brake. Over-tightening can cause overheating, and damage to the brake parts. Tighten the lock nut after adjustment is completed.

If the brake does not respond to adjustment, then a new flat spring (item #3) and/or brake discs (item #31) may be needed.

Brake torque can be checked/set as follows: A torque wrench can be equipped with a special adapter to fit the input coupling of the winch. The adapter can be made by welding a 1" dia. straight motor shaft, with 1/4" key, in a 1" hex. socket, as shown in the following figure.

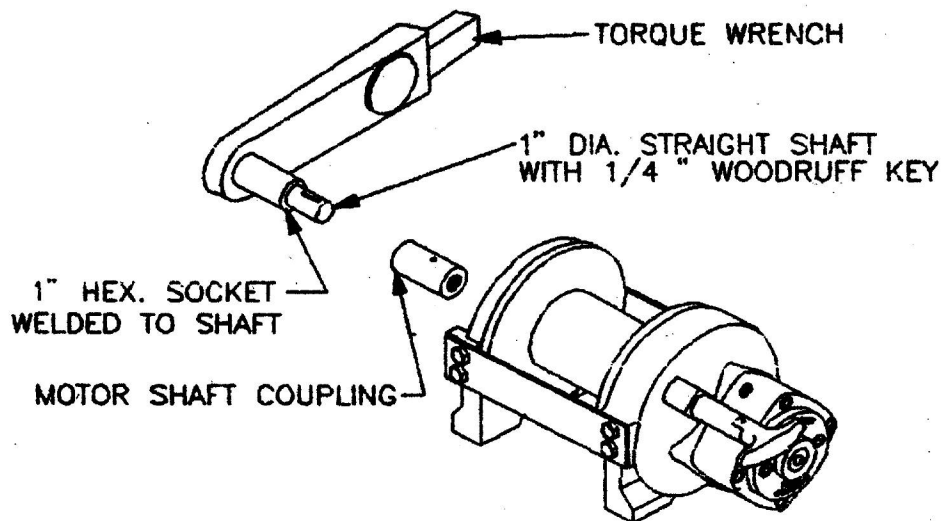

This special adapter will fit into the motor shaft coupling. Place coupling onto drum shaft in winch. Turn the torque wrench so that the drum turns in the "CABLE OUT" direction (lowering direction). The torque setting for the brake should be 155 to 160 ft. lbs. If the torque wrench does not show the proper torque value, the adjusting screw should be adjusted 1/4 turn (clockwise if torque is low or counter-clockwise if torque is high). Each time the adjusting bolt is turned, check the torque reading. Continue this procedure until the proper torque reading is achieved. Then tighten the lock nut. If proper adjustment cannot be made, follow overhaul instructions on page 10.

After the brake has been adjusted to the proper torque setting, as described above, disengage clutch. Start vehicle engine and run winch in the "CABLE IN" (raise direction). Allow winch to run in this direction for one minute.

Place your hand on the brake housing. If housing is not hot to the touch then run winch in the reverse direction (cable out) for one minute. Brake housing should begin to heat.

When these conditions exist, proper installation has been made.

INSTRUCTIONS FOR OVERHAUL OF RAMSEY WINCH MODEL RPH 8,000

Remove breather plug and reducer (item #34 and #39) from winch. Drain oil from winch by removing plug (item #40). Remove motor (item #35), coupling (item #31) from winch by unscrewing capscrews (item #24). If coupling is being replaced, be sure pin (item #41) is installed. Tap motor lightly to disengage. Replace all o-rings and seals with new one during re-assembly (order kit #246042). If necessary, remove valve (item #49) from motor by removing lockwashers (item #52) and capscrews (item #21).

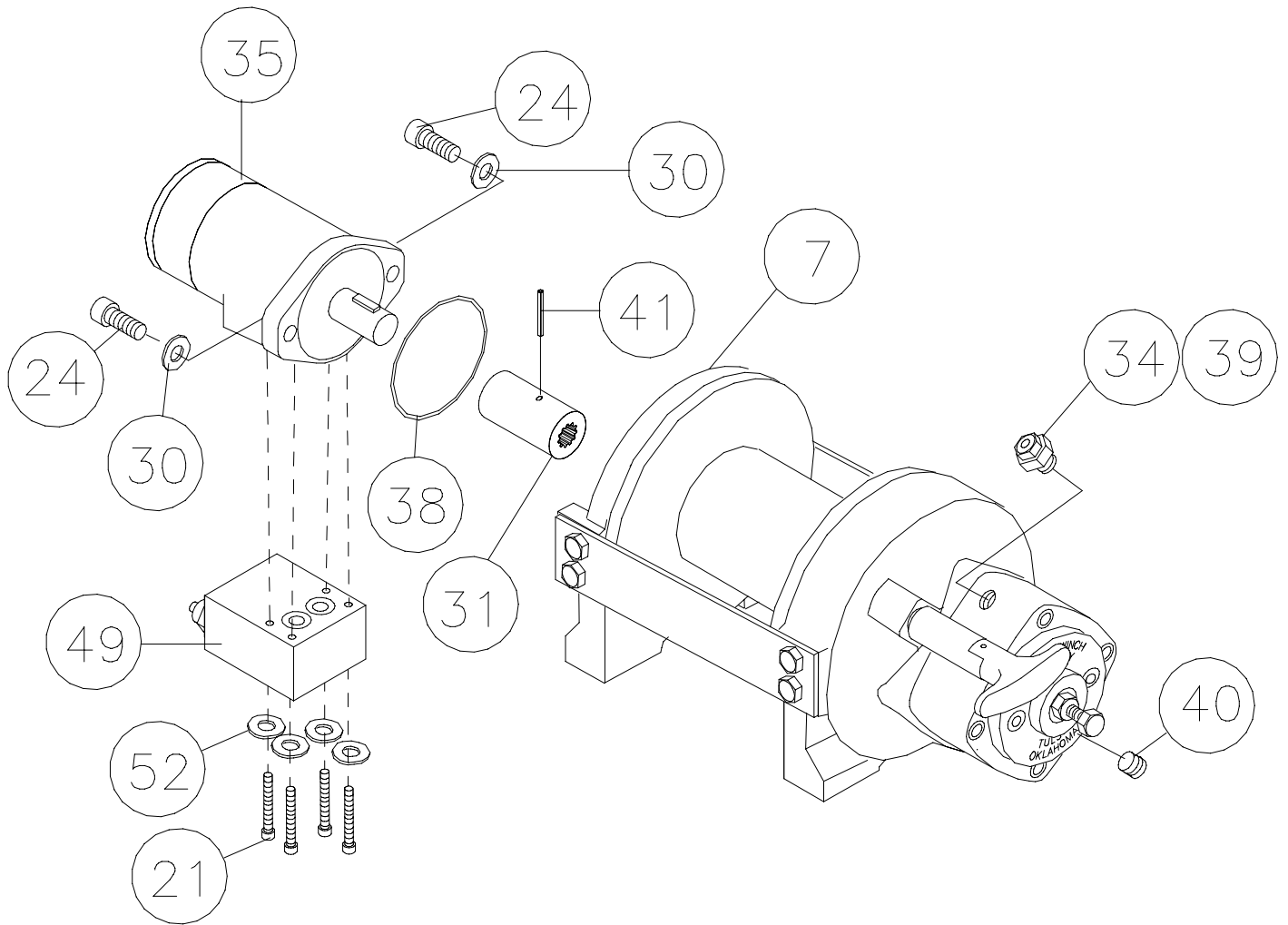

Remove tie plates (item #13) from end bearings (items #7 & #8) by unscrewing capscrews (item #18), as shown. Slide motor end bearing (item #7) from drum (item #1) and drum from gear housing end bearing (item #8). Remove input shaft (item #12) from end bearing. Inspect teeth of gear (item #5) for signs of wear. If necessary replace gear by removing snap ring (item #47) and thrust washer (item #50). Slide new gear over splines of shaft and against snap ring on shaft. Re-install thrust washer and place snap ring into groove of shaft.

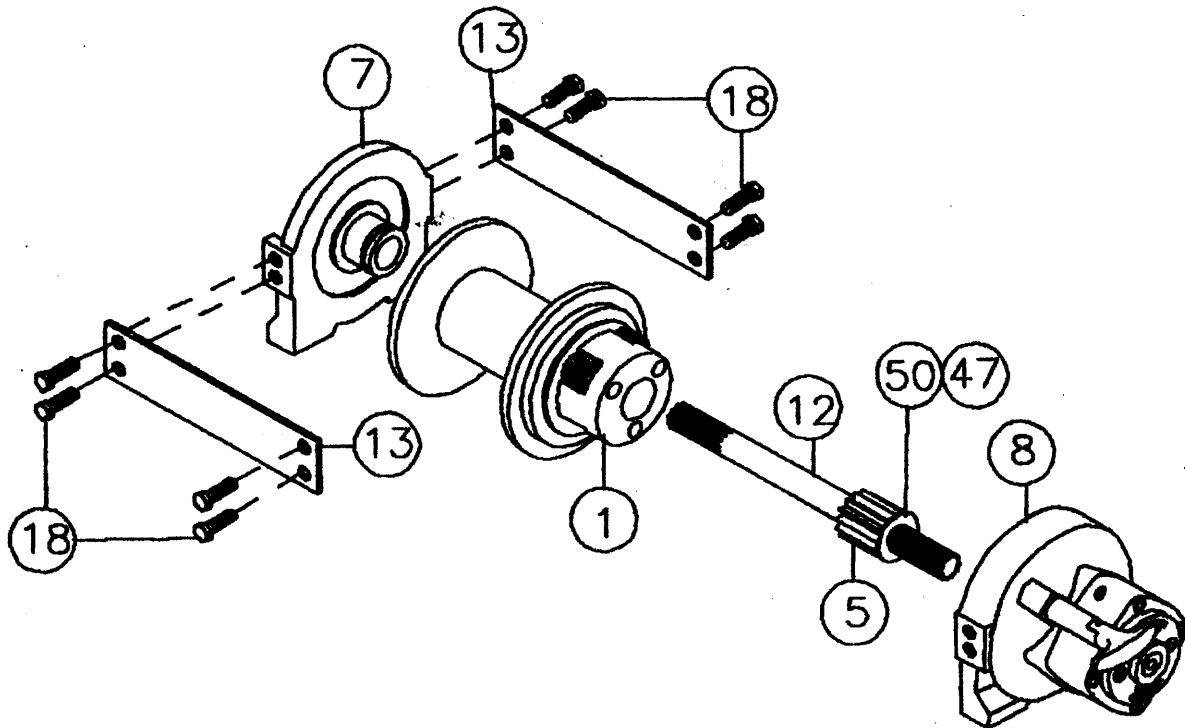

Remove brake housing (item #9) from end bearing (item #8) by unscrewing (4) capscrews (item #23). Remove plate (item #12) and light assembly, if present. Remove gasket (item #33), coil spring (item #48), flat spring (item #3), retainer plate (item #11), composition brake discs (item #32) and cam plate (item #4). Remove hub (item #10) with plug (item #42)-which is press-fitted in the hub I.D. Inspect the seal (item #37), inside of gear housing bore, and replace if necessary.

Inspect brake discs. Discs are 1/4" thick when new, replace if thinner than .200 in. thick or if surfaces are glazed or burnt. Inspect the flat ground surfaces of the cam plate and retainer plate for glazing, warpage or other damage. Glazing can be removed by scraping carefully. Inspect flat spring. It should be bowed at least 1/8". Replace spring if bowed less than 1/8".

Replace all worn or damaged parts as needed. Reassemble all parts as shown. Be sure balls are secure between cam plate and hub.

Install brake housing, making sure that ends of capscrews (item #17) go through notches in end of flat springs and holes in the retainer plate. Secure brake housing and plate (item #12), if present, to end bearing using capscrews (item #23). Tighten capscrews to 30-40 FT.LBS.

INDICATOR LIGHT ASSEMBLY

If light is not functioning, remove light (item #2) and apply 12v DC (+) to test. If necessary, remove the switch (item #52). The terminals are normally closed. With ball depressed, the switch should be open. Replace light and/or switch, as needed.

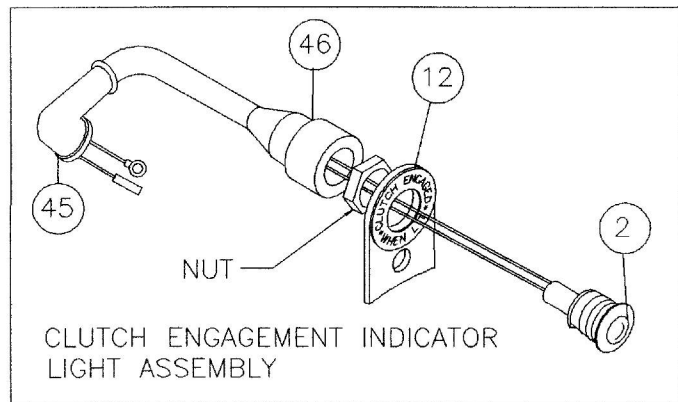
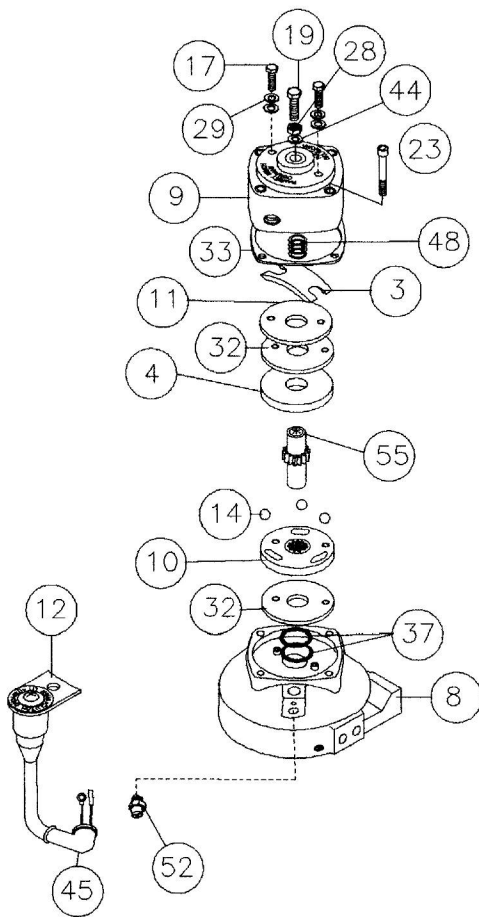

Remove o-ring (item #36) and bushing (item #15) from motor end bearing (item #7). Press new bushing onto end bearing and dip o-ring in oil and seat into groove of end bearing. Remove seal (item #45) from gear housing end bearing (item #8). Loosen nut (item #27) and remove nylon setscrew (item #22) and remove ring gear (item #6) from gear housing end bearing, if necessary. Remove bushing (item #16) from gear housing end bearing (item #8). Press new bushing (item #16) into place in end bearing. Install ring gear and nylon setscrew and nut. Ring gear must be fully seated in gear housing end bearing (item #8) and slot in ring gear must NOT be aligned with clutch shifter hole. Install new seal in gear housing end bearing, with sharp edge of seal outward.

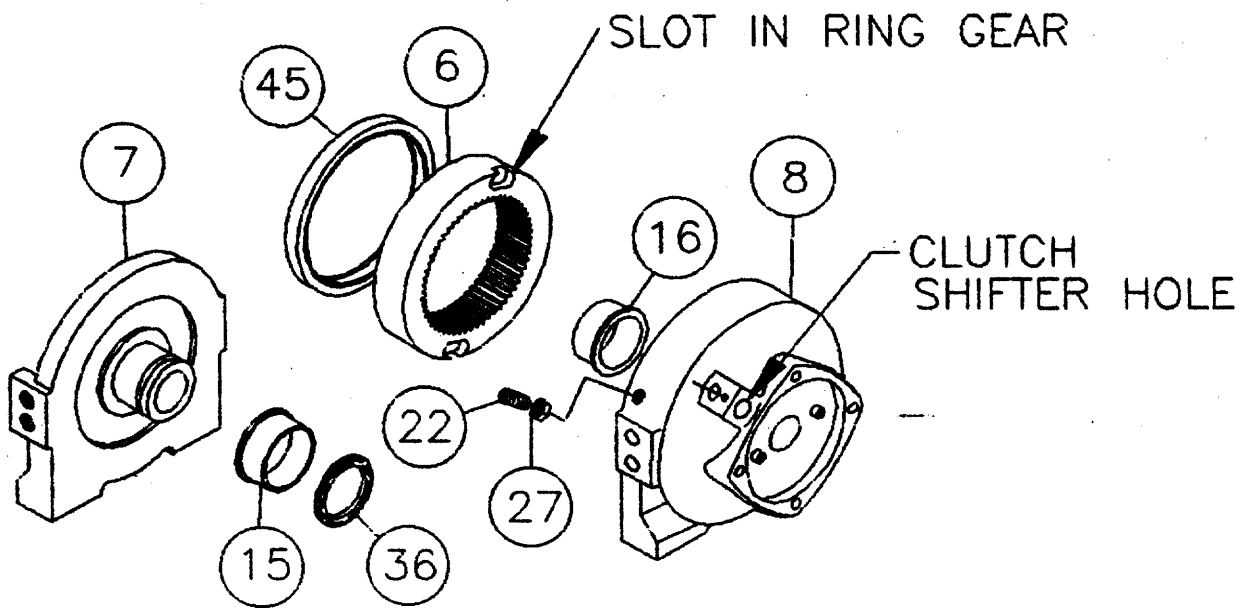

Generously apply grease (MOBILITH SHC 007) to teeth of ring gear (item #6), teeth of planet gears in drum (item #1) and to bushing in end bearings (item #7 & #8). Apply grease to teeth of gear (item #5) and to splines of shaft (item #12). Place splined end of shaft into splines of hub in brake housing end bearing (item #8). Place drum over shaft and rotate drum to engage planet gears with output gear on shaft and ring gear in end bearing.

Assemble end bearing to drum assembly and use tie plates (item #13) and capscrews (item #18) to hold both end bearings together. Tighten capscrews to 55 Ft. Lbs. (75 Nm.). If necessary, remove and replace appropriate shifter assembly (item #2 or #3), as follows:

MANUAL CLUTCH SHIFTER ASSEMBLY

Remove by loosening setscrew (item #25), jam nut and unscrewing clutch shifter. Be sure slot in ring gear is not aligned with clutch shifter hole. Rotate drum, if necessary, to insure hole and slot are not aligned. Reinstall clutch shifter with plunger, jam nut and handle positioned in cylinder housing, as shown. Thread assembly (with handle engaged in cylinder slot) into the end bearing. Pull drum toward the brake housing end bearing to remove play. Hold drum in the position and continue threading the shifter assembly in until the gap between the end of the handle and cylinder is $7/16^{+0}_{-1/16}$ inch and handle is in the horizontal position, as shown below. **NOTE:** This gap will vary with drum endplay. With the drum pulled against the gear housing, the gap should be $7/16$ inch. Lightly tighten jam nut. Rotate drum until handle snaps fully into the engaged position. Pull handle out and rotate 90° . Verify that drum can be rotated freely (at least one full revolution) with clutch shifter at DISENGAGED position. Securely tighten jam nut while holding the handle. Tighten setscrew securely. Re-check clutch operation as described on page 5.

AIR CYLINDER SHIFTER ASSEMBLY

Remove by loosening setscrew (item #25), jam nut and unscrewing clutch shifter. To reinstall, thread air cylinder into housing. Install one or two shims (item #49) under cylinder head, if needed, to orient air cylinder port for pneumatic connections. Tighten setscrew. Refer to page 5 and check for proper operation of the clutch.

BLOCKED CLUTCH

Insert plunger assembly into gear housing bore so it engages into ring gear slot. Pull drum flange toward gear housing and thread setscrew into housing until it bottoms out and drum starts to move. Back setscrew out $1/2$ turn and lock in place with jam nut.

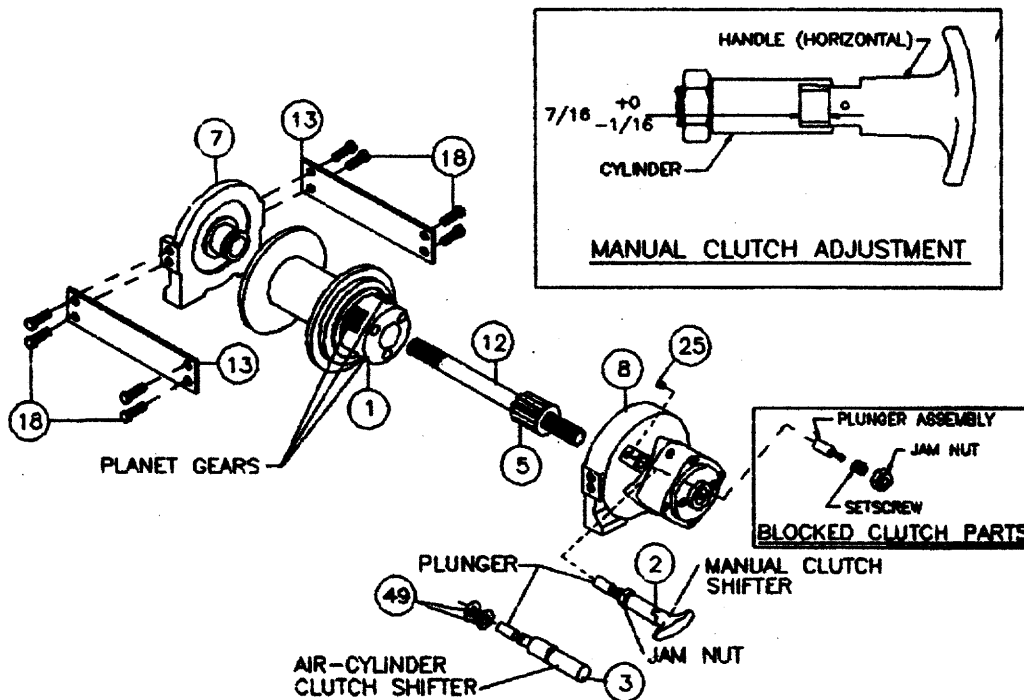

Before installing motor, check brake adjustment (refer to page 7, ADJUSTING THE BRAKE).

Place splined end of coupling (item #31), with spirol pin (item #41) installed, inside of motor end bearing housing (item #7) and slide over splines on end of input shaft. Place o-ring (item #38) around motor pilot. Mount motor (item #35) to end bearing by aligning key on motor shaft with keyway in coupling. Be sure that motor mounts flush to end bearing and that o-ring is set securely in place between motor and end bearing. Secure motor to end bearing using two capscrews and lockwashers (items #24 & #30). Tighten capscrews to 49 Ft.Lbs. (66 Nm). Thread plug (item #40) into bottom of brake housing. Permatex can be added to threads of plug to help in sealing.

Pour a mixture of 1/2 pint (8 oz.) of Mobilfluid 424, Phillips HG Fluid, Texaco TDH, Shell Oil Co. Donax TD high performance tractor transmission fluid, or equivalent, and 1/4 oz. of an oil additive (available from the factory) into oil level hole. Oil level should be kept at oil level hole (plus or minus 1/8"). Thread plug (item #40) into oil level hole. Insert reducer (item #39) into hole in top of brake housing and breather plug (item #34) into reducer. Tighten plugs and reducer securely.

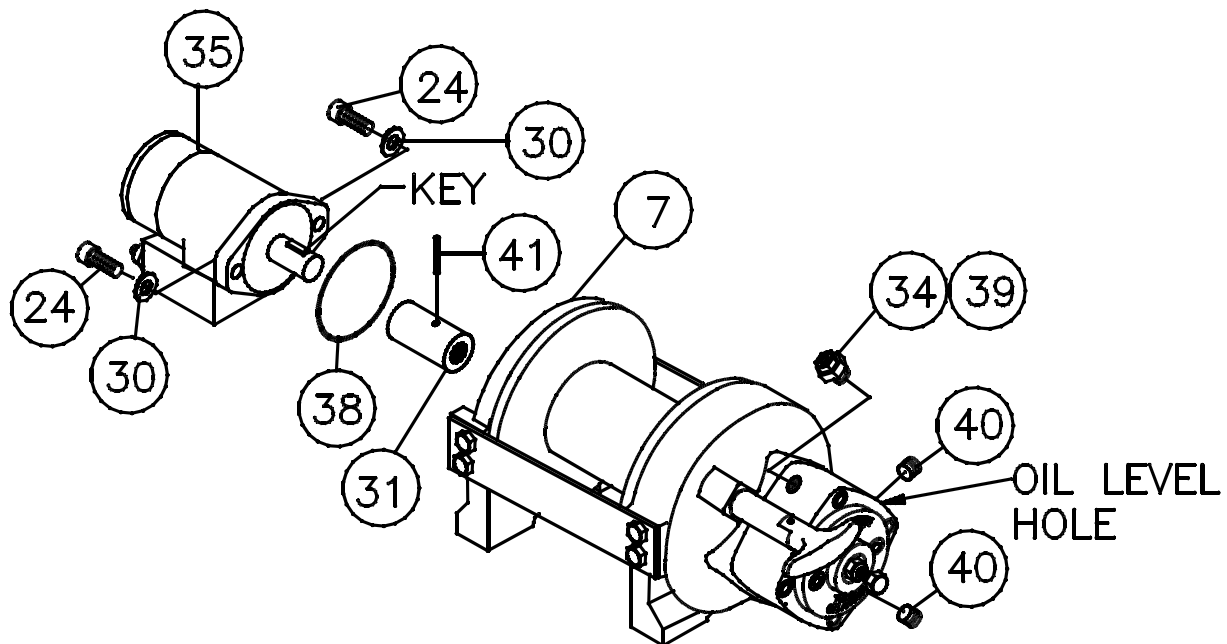

DIM. LETTER	RPH-8000-S ("STD." DRUM)	RPH-8000-Y ("Y" DRUM)
A	9.75 247.6	6.50 165.1
* B	12.25 311.1	9.00 228.6
C	26.75 679.4	23.50 596.9

MOTOR/COUNTERBALANCE VALVE MAY BE MOUNTED WITH PORTS UP

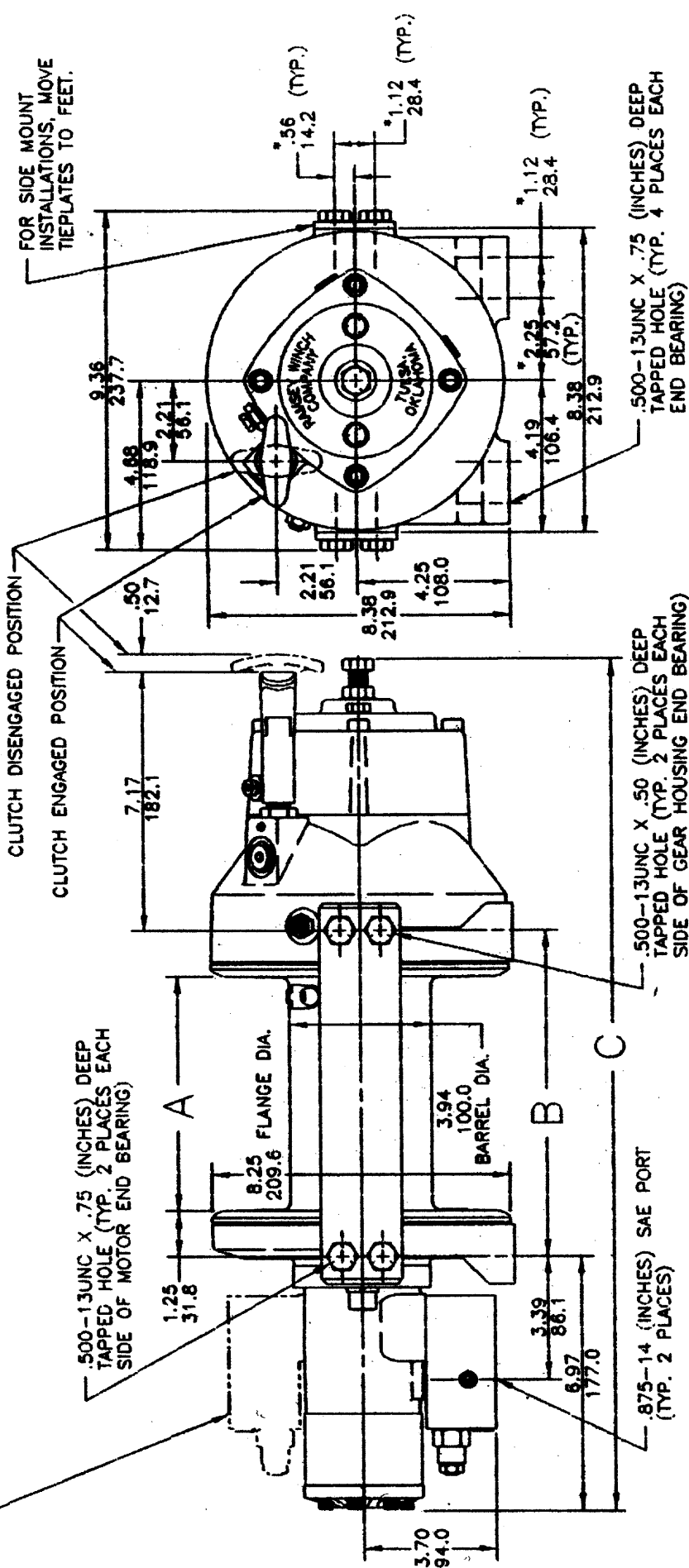

MODEL RPH 8,000

WITH MANUAL CLUTCH SHIFTER

DIMENSIONS SHOWN ARE INCHES OVER MILLIMETERS
WINCH MOUNTING CAPSCREWS MUST MEET OR EXCEED SAE GRADE 5 SPECIFICATION

*NOTE: THESE HOLE LOCATIONS MUST BE HELD WITHIN ±.03" (0.8 MM) OF TRUE POSITION. RECOMMENDED MOUNTING HOLE DIAMETER IS .53" (13.5 MM).

DIM. LETTER	RPH-8000-S ("Y" DRUM)	RPH-8000-Y ("Y" DRUM)
A	9.75 247.6	6.50 165.1
* B	12.25 311.1	9.00 228.6
C	26.75 679.4	23.50 596.9

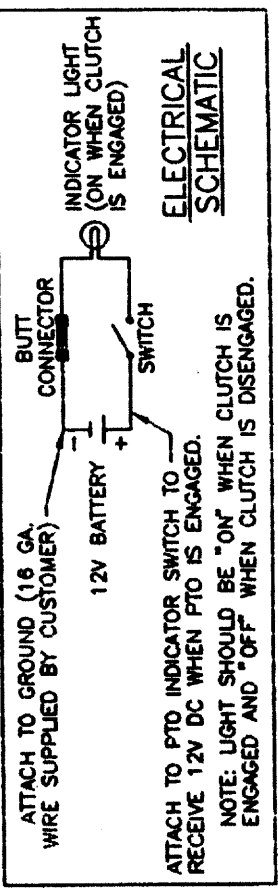
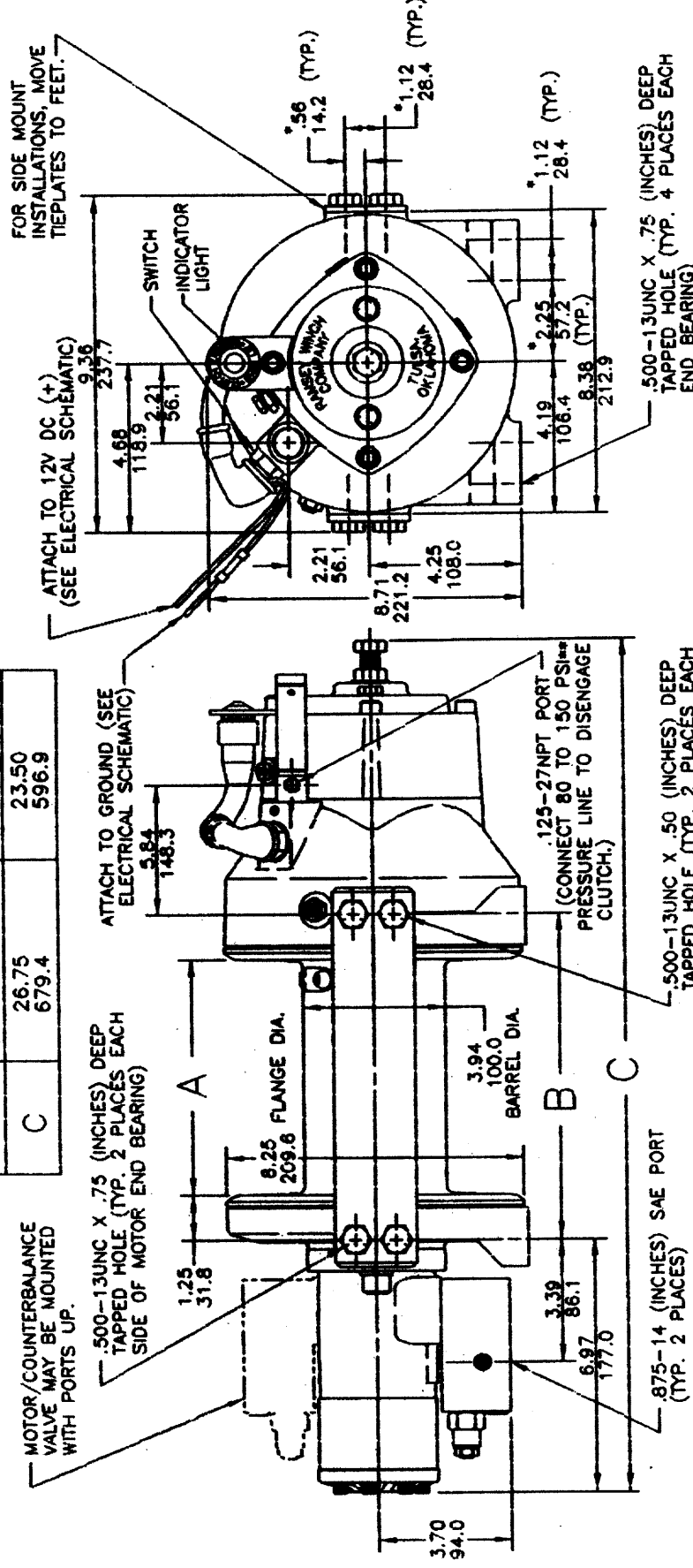

DIMENSIONS SHOWN ARE INCHES OVER MILLIMETERS
WHICH MOUNTING CAPSCREWS MUST MEET OR EXCEED SAE GRADE 5 SPECIFICATION
 *NOTE: THESE HOLE LOCATIONS MUST BE HELD WITHIN ±.03" (0.8 MM) OF TRUE POSITION. RECOMMENDED MOUNTING HOLE DIAMETER IS .53" (13.5 MM).

MODEL RPH 8,000

WITH AIR-CYLINDER CLUTCH SHIFTER

PARTS LIST RPH-8,000 WITH MANUAL CLUTCH SHIFTER

<u>ITEM</u>	<u>QTY.</u>	<u>PART NO.</u>	<u>DESCRIPTION</u>
1	1	234165	DRUM ASS'Y. "Y"
	1	234166	DRUM ASS'Y. "STD."
2	1	276048	SHIFTER ASS'Y.
3	1	306035	SPRING-FLAT, BRK.
*4	1	314017	CAM PLATE-"A" ROTATION
	1	314018	CAM PLATE-"B" ROTATION
5	1	334174	GEAR-OUTPUT, SUN
6	1	444084	GEAR-RING
**7	1	338326	END BEARING-MOTOR
**8	1	338327	HOUSING-GEAR, END BEARING
**9	1	338328	HOUSING-BRAKE
*10	1	314019	HUB PLATE
11	1	352021	RETAINER PLATE
12	1	357489	SHAFT-INPUT "Y"
	1	357490	SHAFT-INPUT "STD."
13	2	395163	TIE PLATE "Y"
	2	395172	TIE PLATE "STD."
*14	3	400007	BALL
15	1	412084	BUSHING-DRUM, MOTOR END
16	1	412085	BUSHING-DRUM, GEAR
17	2	414273	BOLT-3/8-16NC X 1-3/4, HX, GR. 5
18	8	414581	CAPSCREW-1/2-13NC X 3/4 LG. HX. HD., GR. 5, Z/P
19	1	414622	BOLT-1/2-13NC X 2-1/4, HX. HD., GR. 5, ALL-THD.
20	2	414836	CAPSCREW-1/4-20NC X 1/2, HX. SOC. HD.
21	4	414159	CAPSCREW-5/16-18NC X 2-1/2, HX. HD. GR5 Z/P
22	1	414926	SETSCREW-3/8-16NC X 1, SOCKET, NYLON
23	4	414934	CAPSCREW-3/8-16NC X 2-3/4, HX. SOC. HD.
24	2	414952	CAPSCREW-1/2-13NC X 1-1/2, SOC. HD.
25	1	416016	SETSCREW-1/4-20NC X 1/4 HX. SOC. HD.
**26	2	418034	NUT 3/8-16NC HEX.REG.
27	1	418036	NUT 3/8-16NC HEX. JAM
28	1	418061	NUT-1/2-13NC HEX. JAM
29	4	418184	WASHER-3/8 ID X 5/8 OD X 1/16 FLAT ALUM
30	2	418218	LOCKWASHER-1/2 ID MED. SECT.
31	1	431014	COUPLING-HYD. MOTOR
32	2	438018	PLATE-BRAKE
33	1	442212	GASKET-BRK. HSG.
34	1	456008	RELIEF FITTING
35	1	458074	MOTOR-HYD. (FOR MODEL WITH COUNTERBALANCE VALVE)
	1	458075	MOTOR-HYD. (FOR MODEL WITHOUT COUNTERBALANCE VALVE)
36	1	462046	O-RING
37	2	462047	QUAD-RING
38	1	462048	O-RING
39	1	468002	REDUCER
40	2	468018	PIPE PLUG
41	1	470033	SPIROL PIN
*42	1	472051	PLUG
43	1	472052	PLUG
44	1	486076	SEAL
45	1	486080	SEAL-GEAR HSG.
46	1	518037	SHIM
47	2	490003	SNAP RING
48	1	494010	SPRING
49	1	516008	VALVE-COUNTERBALANCE ("A" ROTATION)
	1	516009	VALVE-COUNTERBALANCE ("B" ROTATION)
50	1	518047	WASHER-THRUST
*51	1	340077	BRAKE SHAFT
52	4	418163	LOCKWASHER - 5/16 MED SECT Z/P

* EFFECTIVE SERIAL NUMBER: 2038147

** EFFECTIVE DATE CODE: H07702041

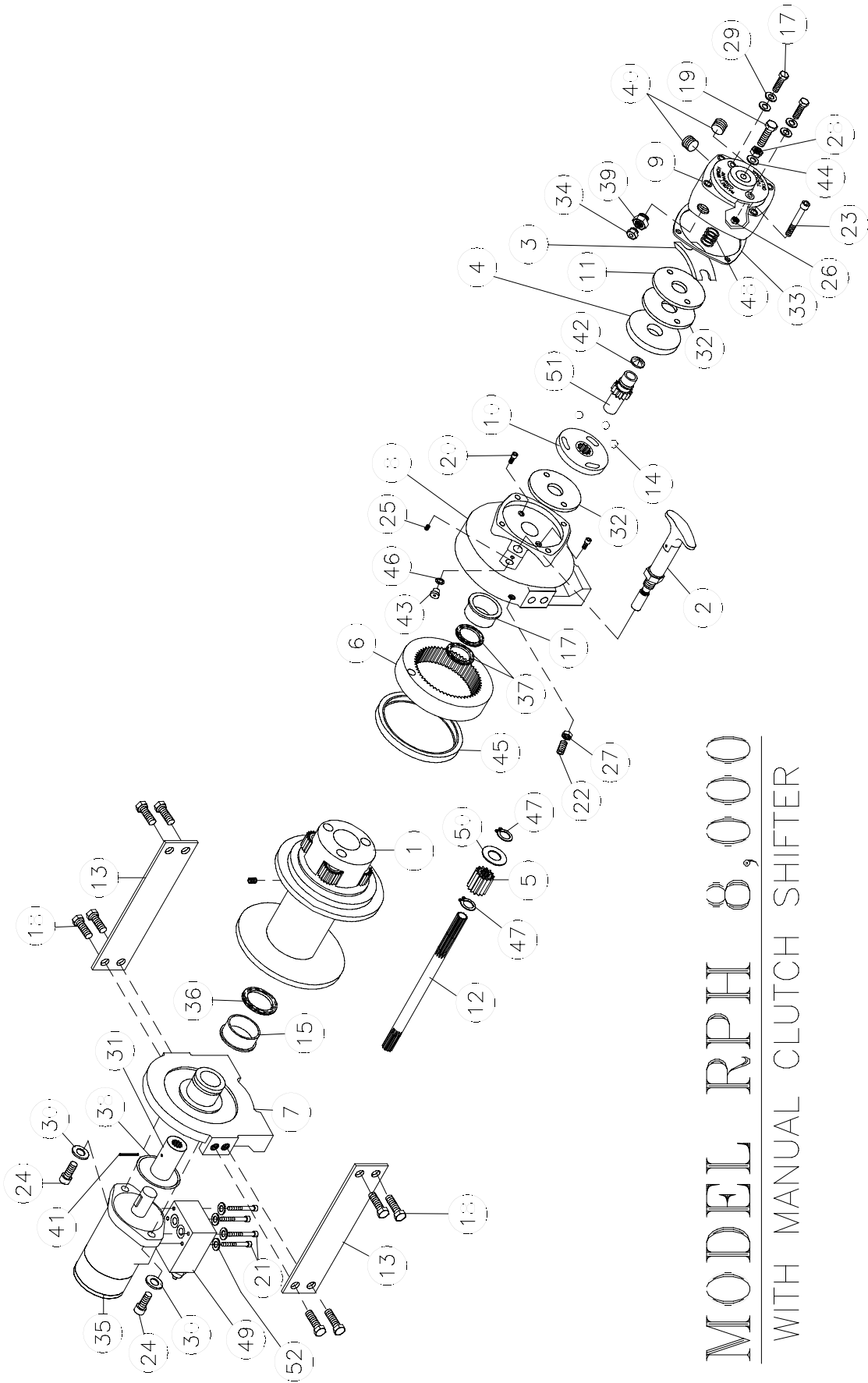

MODEL RPH 8,000
 WITH MANUAL CLUTCH SHIFTER

**PARTS LIST RPH-8,000 WITH MANUAL CLUTCH SHIFTER
AND CLUTCH ENGAGEMENT INDICATOR LIGHT**

<u>ITEM</u>	<u>QTY.</u>	<u>PART NO.</u>	<u>DESCRIPTION</u>
1	1	234165	DRUM ASS'Y. "Y"
	1	234166	DRUM ASS'Y. "STD."
2	1	236020	LIGHT ASS'Y.
3	1	276048	SHIFTER ASS'Y.
4	1	306035	SPRING-FLAT, BRK.
*5	1	314017	CAM PLATE-"A" ROTATION
	1	314018	CAM PLATE-"B" ROTATION
6	1	334174	GEAR-OUTPUT, SUN
7	1	444084	GEAR-RING
**8	1	338326	END BEARING-MOTOR
**9	1	338327	HOUSING-GEAR, END BEARING
**10	1	338328	HOUSING-BRAKE
11	1	314019	HUB PLATE
12	1	350598	PLATE-LIGHT MTG.
13	1	352021	RETAINER PLATE
14	1	357489	SHAFT-INPUT "Y"
	1	357490	SHAFT-INPUT "STD."
15	2	395163	TIE PLATE "Y"
	2	395172	TIE PLATE "STD."
*16	3	400007	BALL
17	1	412084	BUSHING-DRUM, MOTOR END
18	1	412085	BUSHING-DRUM, GEAR
19	2	414273	BOLT-3/8-16NC X 1-3/4, HX, GR. 5
20	8	414581	CAPSCREW-1/2-13NC X 3/4 LG. HX. HD., GR. 5, Z/P
21	1	414622	BOLT-1/2-13NC X 2-1/4, HX. HD., GR. 5, ALL-THD.
22	2	414836	CAPSCREW-1/4-20NC X 1/2, HX. SOC. HD.
23	4	414159	CAPSCREW-5/16-18NC X 2-1/2, HX. HD. GR5 Z/P
24	1	414926	SETSCREW-3/8-16NC X 1, SOCKET, NYLON
25	4	414934	CAPSCREW-3/8-16NC X 2-3/4, HX. SOC. HD.
26	2	414952	CAPSCREW-1/2-13NC X 1-1/2, SOC. HD.
27	1	416016	SETSCREW-1/4-20NC X 1/4 HX. SOC. HD.
**28	2	418034	NUT 3/8-16NC HEX.REG.
29	1	418036	NUT 3/8-16NC HEX. JAM
30	1	418061	NUT-1/2-13NC HEX. JAM
31	4	418184	WASHER-3/8 ID X 5/8 OD X 1/16 FLAT ALUM
32	2	418218	LOCKWASHER-1/2 ID MED. SECT.
33	1	431014	COUPLING-HYD. MOTOR
34	2	438018	PLATE-BRAKE
35	1	442212	GASKET-BRK. HSG.
36	1	456008	RELIEF FITTING
37	1	458074	MOTOR-HYD. (FOR MODEL WITH COUNTERBALANCE VALVE)
	1	458075	MOTOR-HYD. (FOR MODEL WITHOUT COUNTERBALANCE VALVE)
38	1	462046	O-RING
39	2	462047	QUAD-RING
40	1	462048	O-RING
41	1	468002	REDUCER
42	2	468018	PIPE PLUG
43	1	470033	SPIROL PIN
*44	1	472051	PLUG
45	1	482013	GROMMET
46	1	482045	RUBBER BOOT
47	1	486076	SEAL
48	1	486080	SEAL-GEAR HSG.
49	2	490003	SNAP RING
50	1	494010	SPRING
51	1	504021	SWITCH ASS'Y.
52	1	516008	VALVE-COUNTERBALANCE ("A" ROTATION)
	1	516009	VALVE-COUNTERBALANCE ("B" ROTATION)
53	1	518047	WASHER-THRUST
*54	1	340077	SHAFT - BRAKE
55	4	418163	LOCKWASHER - 5/16 MED SECT Z/P

* EFFECTIVE SERIAL NUMBER: 2038147

** EFFECTIVE DATE CODE: H07702041

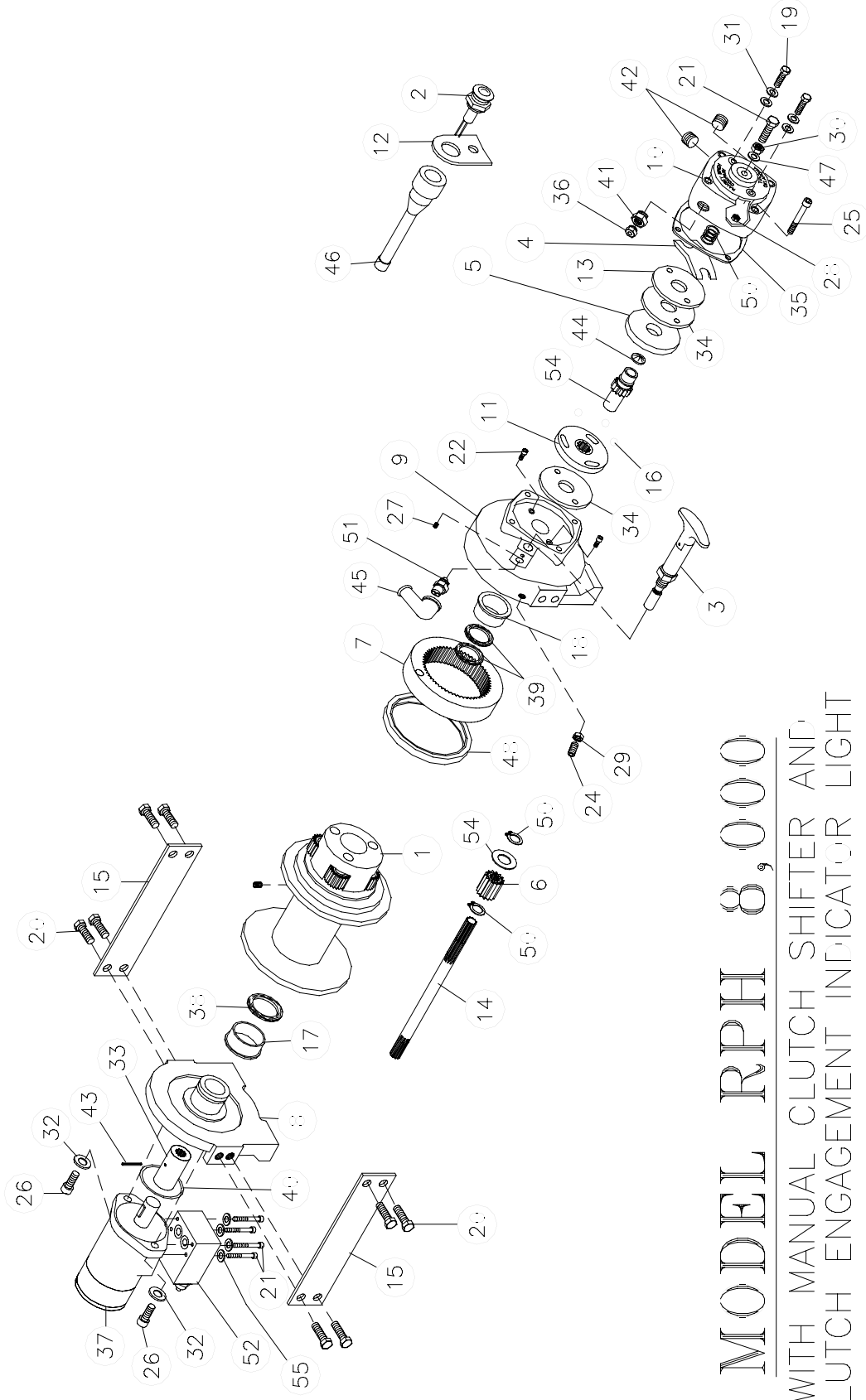

MODEL RPH 8,000
 WITH MANUAL CLUTCH SHIFTER AND
 CLUTCH ENGAGEMENT INDICATOR LIGHT

PARTS LIST RPH-8,000 WITH AIR-CYLINDER CLUTCH SHIFTER

ITEM	QTY.	PART NO.	DESCRIPTION
1	1	234165	DRUM ASS'Y. "Y"
	1	234166	DRUM ASS'Y. "STD."
2	1	236020	LIGHT ASS'Y.
3	1	276058	SHIFTER ASS'Y.-AIR
4	1	306035	SPRING-FLAT, BRK.
*5	1	314017	CAM PLATE-"A" ROTATION
	1	314018	CAM PLATE-"B" ROTATION
6	1	334174	GEAR-OUTPUT, SUN
7	1	444084	GEAR-RING
**8	1	338326	END BEARING-MOTOR
**9	1	338327	HOUSING-GEAR, END BEARING
**10	1	338328	HOUSING-BRAKE
*11	1	314019	HUB-PLATE
12	1	350598	PLATE-LIGHT MTG.
13	1	352021	RETAINER PLATE
14	1	357489	SHAFT-INPUT "Y"
	1	357490	SHAFT-INPUT "STD."
15	2	395163	TIE PLATE "Y"
	2	395172	TIE PLATE "STD."
*16	3	400007	BALL
17	1	412084	BUSHING-DRUM, MOTOR END
18	1	412085	BUSHING-DRUM, GEAR
19	2	414273	BOLT-3/8-16NC X 1-3/4, HX, GR. 5
20	8	414581	CAPSCREW-1/2-13NC X 3/4 LG. HX. HD., GR. 5, Z/P
21	1	414622	BOLT-1/2-13NC X 2-1/4, HX. HD., GR. 5, ALL-THD.
22	2	414836	CAPSCREW-1/4-20NC X 1/2, HX. SOC. HD.
23	4	414159	CAPSCREW-5/16-18NC X 2-1/2, HX. HD., GR5 Z/P
24	1	414926	SETSCREW-3/8-16NC X 1, SOCKET, NYLON
25	4	414934	CAPSCREW-3/8-16NC X 2-3/4, HX. SOC. HD.
26	2	414952	CAPSCREW-1/2-13NC X 1-1/2, SOC. HD.
27	1	416016	SETSCREW-1/4-20NC X 1/4 HX. SOC. HD.
**28	2	418034	NUT 3/8-16NC HEX.REG.
29	1	418036	NUT 3/8-16NC HEX. JAM
30	1	418061	NUT-1/2-13NC HEX. JAM
31	4	418184	WASHER-3/8 ID X 5/8 OD X 1/16 FLAT ALUM
32	2	418218	LOCKWASHER-1/2 ID MED. SECT.
33	1	431014	COUPLING-HYD. MOTOR
34	2	438018	PLATE-BRAKE
35	1	442212	GASKET-BRK. HSG.
36	1	456008	RELIEF FITTING
37	1	458074	MOTOR-HYD. (FOR MODEL WITH COUNTERBALANCE VALVE)
	1	458075	MOTOR-HYD. (FOR MODEL WITHOUT COUNTERBALANCE VALVE)
38	1	462046	O-RING
39	2	462047	QUAD-RING
40	1	462048	O-RING
41	1	468002	REDUCER
42	2	468018	PIPE PLUG
43	1	470033	SPIROL PIN
*44	1	472051	PLUG
45	1	482013	GROMMET
46	1	482045	RUBBER BOOT
47	1	486076	SEAL
48	1	486080	SEAL-GEAR HSG.
49	2	488007	SHIM
50	2	490003	SNAP RING
51	1	494010	SPRING
52	1	504021	SWITCH ASS'Y.
53	1	516008	VALVE-COUNTERBALANCE ("A" ROTATION)
	1	516009	VALVE-COUNTERBALANCE ("B" ROTATION)
54	1	518047	WASHER-THRUST
55	1	340077	SHAFT - BRAKE
*56	4	418163	LOCKWASHER 5/16 MED SECT Z/P

* EFFECTIVE SERIAL NUMBER: 2038147

** EFFECTIVE DATE CODE: H07702041

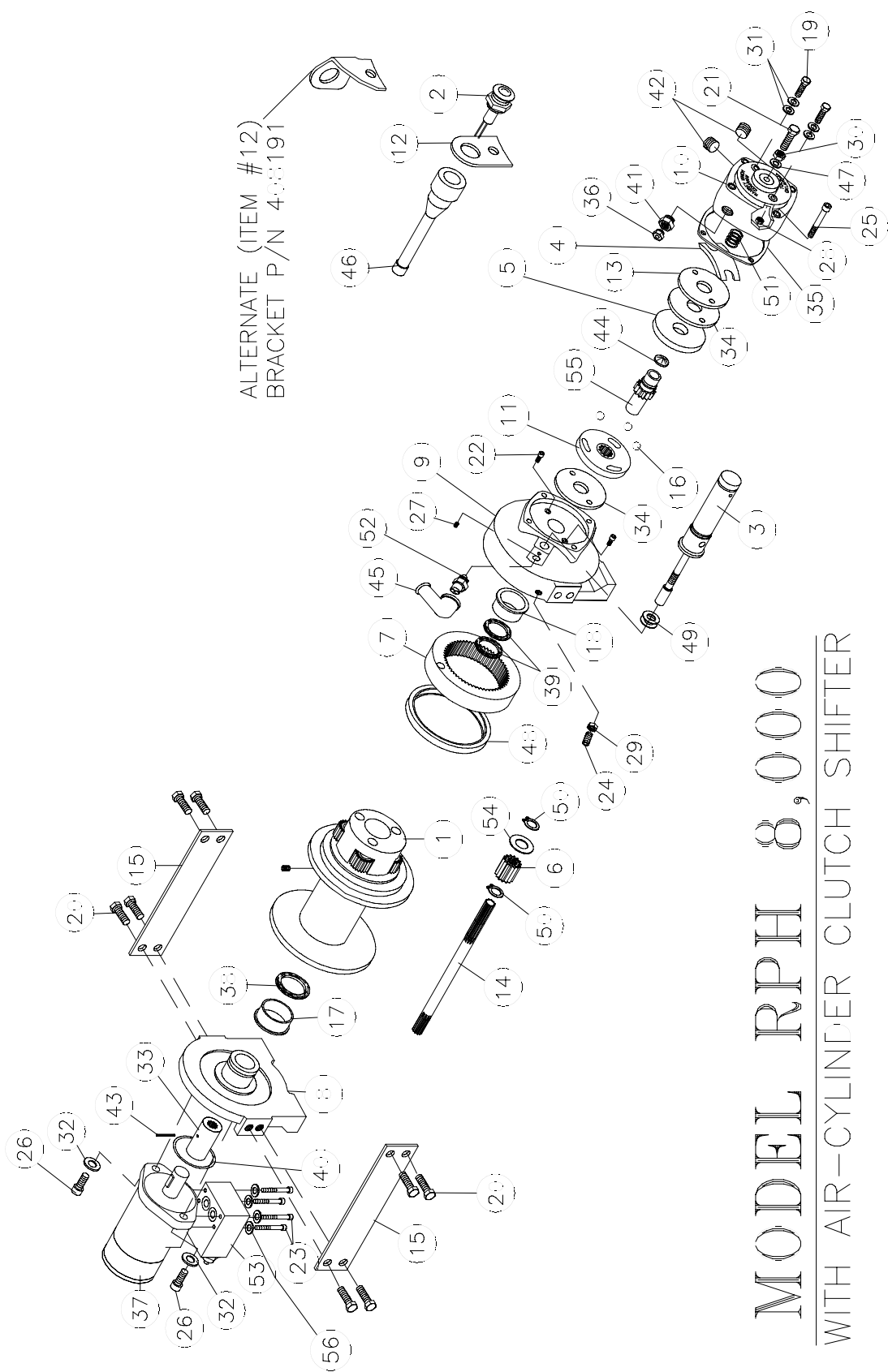

ALTERNATE (ITEM #12)
BRACKET P/N 4-0191

MODEL RPH 8,000
WITH AIR-CYLINDER CLUTCH SHIFTER

PARTS LIST RPH-8,000 WITH BLOCKED CLUTCH

ITEM	QTY.	PART NO.	DESCRIPTION
1	1	234166	DRUM ASS'Y. "STD."
2	1	299693	PLUNGER ASSY.
3	1	306035	SPRING-FLAT, BRK.
*4	1	314017	CAM PLATE-"A" ROTATION
	1	314018	CAM PLATE-"B" ROTATION
5	1	334174	GEAR-OUTPUT, SUN
6	1	444084	GEAR-RING
**7	1	338326	END BEARING-MOTOR
**8	1	338327	HOUSING-GEAR, END BEARING
**9	1	338328	HOUSING-BRAKE
*10	1	314019	HUB-PLATE
11	1	352021	RETAINER PLATE
12	1	357490	SHAFT-INPUT
13	2	395172	TIE PLATE
*14	3	400007	BALL
15	1	412084	BUSHING-DRUM, MOTOR END
16	1	412085	BUSHING-DRUM, GEAR
17	2	414273	BOLT-3/8-16NC X 1-3/4, HX, GR. 5
18	8	414581	CAPSCREW-1/2-13NC X 3/4 LG. HX. HD., GR. 5, Z/P
19	1	414622	BOLT-1/2-13NC X 2-1/4, HX. HD., GR. 5, ALL-THD.
20	2	414836	CAPSCREW-1/4-20NC X 1/2, HX. SOC. HD.
21	4	414159	CAPSCREW-5/16-18NC X 2-1/2, HX. HD., GR5 Z/P
22	1	414926	SETSCREW-3/8-16NC X 1, SOCKET, NYLON
23	4	414934	CAPSCREW-3/8-16NC X 2-3/4, HX. SOC. HD.
24	2	414952	CAPSCREW-1/2-13NC X 1-1/2, SOC. HD.
25	1	416016	SETSCREW-1/4-20NC X 1/4 HX. SOC. HD.
**26	2	418034	NUT 3/8-16NC HEX.REG.
27	1	418036	NUT 3/8-16NC HEX. JAM
28	1	418061	NUT-1/2-13NC HEX. JAM
29	1	418088	NUT-JAM 5/8-18NF HX Z/P
30	4	418184	WASHER-3/8 ID X 5/8 OD X 1/16 FLAT ALUM
31	2	418218	LOCKWASHER-1/2 ID MED. SECT.
32	1	431014	COUPLING-HYD. MOTOR
33	2	438018	PLATE-BRAKE
34	1	442212	GASKET-BRK. HSG.
35	1	456008	RELIEF FITTING
36	1	458075	MOTOR-HYD. (FOR MODEL WITH COUNTERBALANCE VALVE)
37	1	462046	O-RING
38	2	462047	QUAD-RING
39	1	462048	O-RING
40	1	468002	REDUCER
41	2	468018	PIPE PLUG
42	1	470033	SPIROL PIN
*43	1	472051	PLUG
44	1	472052	PLUG
45	1	486076	SEAL
46	1	486080	SEAL-GEAR HSG.
47	1	518037	SHIM
48	2	490003	SNAP RING
49	1	494010	SPRING
50	1	518047	WASHER-THRUST
*51	1	340077	SHAFT - BRAKE

* EFFECTIVE SERIAL NUMBER: 2038147

** EFFECTIVE DATE CODE: H07702041

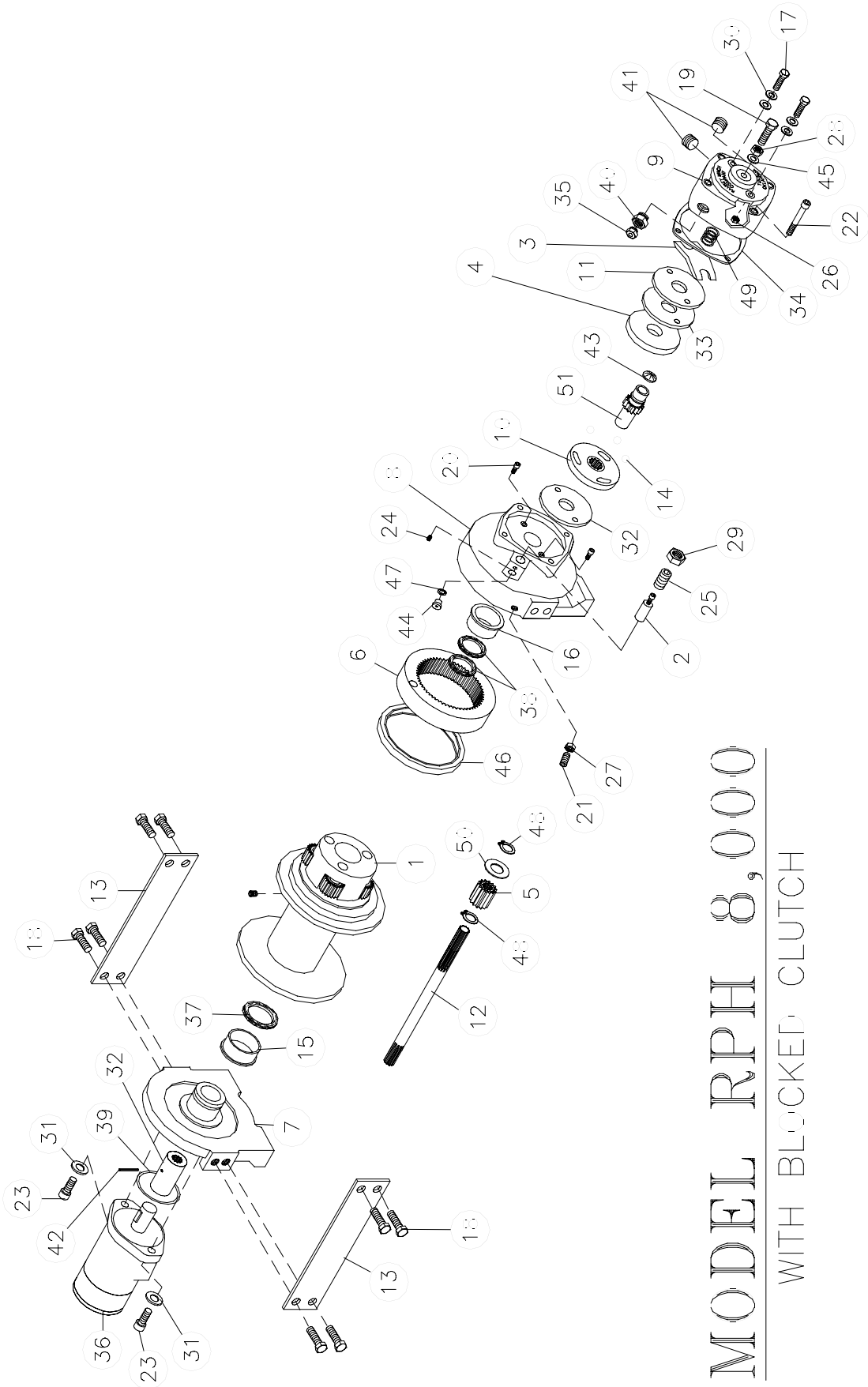

MODEL RPH 8,000

WITH BLOCKED CLUTCH

NOTES

NOTES

LIMITED WARRANTY

RAMSEY WINCH warrants each new RAMSEY WINCH to be free from defects in material and workmanship for a period of one (1) year from date of purchase.

The obligation under this warranty, statutory or otherwise, is limited to the replacement or repair at the Manufacturer's factory, or at a point designated by the Manufacturer, of such part that shall appear to the Manufacturer, upon inspection of such part, to have been defective in material or workmanship. This warranty does not obligate RAMSEY WINCH to bear the cost of labor or transportation charges in connection with the replacement or repair of defective parts, nor shall it apply to a product upon which repair or alterations have been made, unless authorized by Manufacturer, or for equipment misused, neglected, or which has not been installed correctly.

RAMSEY WINCH shall in no event be liable for special or consequential damages. RAMSEY WINCH makes no warranty in respect to accessories such as being subject to the warranties of their respective manufacturers. RAMSEY WINCH, whose policy is one of continuous improvement, reserves the right to improve its products through changes in design or materials as it may deem desirable without being obligated to incorporate such changes in products of prior manufacture.

If field service at the request of the Buyer is rendered and the fault is found not to be with RAMSEY WINCH's product, the Buyer shall pay the time and expense to the field representative. Bills for service, labor, or other expenses that have been incurred by the Buyer without the approval or authorization by RAMSEY WINCH will not be accepted.

See warranty card for details.



RAMSEY WINCH COMPANY

P.O. BOX 581510

TULSA, OKLAHOMA 74158-1510

TELEPHONE: (918) 438-2760

FAX: (918) 438-6688

<http://www.ramsey.com>