



SoundOff Signal
 3900 Central Parkway
 Hudsonville, MI 49426
 Ph: 800.338.7337
 Ph: 616.896.7100
 Fx: 616.896.1286



Function Table				
Wire	AWG	Color	Item	Function
1	20	Green	Switch 1	
2	20	Yellow	Switch 2	
3	20	Orange	Switch 3	
4	20	Brown	Switch 4	
5	20	Gray	Switch 5	
6	20	Violet	Switch 6	
7	20	Black	Ground	Ground
8	20	Pink	Ignition	Ignition
9	20	Blue	Gun Lock	Gun Lock
10	14	Red	Power	Power

Function column intentionally left blank. Please fill in appropriate functions and store in glove box for future reference / tech support.

ETSP993 IntelliSwitch993

Thank you for purchasing this SoundOff Signal product. With proper installation and care, this unit will provide years of trouble-free service.

ETSP993 Smart Panel Wiring Instructions

Operation Notes

1. Install RED (J4-1) Power wire. Protect the circuit with a 15 Amp fuse (not supplied).
2. Install BLACK (J3-3) to Chassis Ground wire.
3. Install TAN (J3-2) to an ignition +12v circuit, 100mA input.
4. Install all of the outputs 1 through 6 to the various light bar outputs and other lights, (2 amps each output).
5. Install blue wire to Gun Lock output (+12v signal).
6. Test installation of each light by pressing corresponding switch on Smart Panel.

1. If a switch has been associated with the Pursuit switch, it can always be operated normally by pushing one (1) time to turn ON and a second (2nd) time to turn OFF.
2. If a switch has been associated with and turned on via the Pursuit switch it can be turned OFF by pushing it one (1) time.
3. If no buttons are pressed for one (1) minute while in programming mode, the unit will save the current settings and exit programming mode automatically.

Warning : In standard format, each switch is ONLY rated for a maximum 2 Amp load per switch! Should your amp draw requirements exceed 2 Amps per switch, call 800-338-7337 to order our optional in-line 40 Amp relay kit, part number PSPORK1. This kit will increase the maximum amp load capacity of one switch/lead to 40 Amps. List Price is \$35.30 each.

Scrape away any paint from the selected bolt hole and use a star washer and ring terminal to ensure a good, secure electrical connection to the chassis. The chassis ground must not be an insulated point.

Note: When drilling into any vehicle structure, ensure that both sides of the surface are clear of anything that can be damaged.

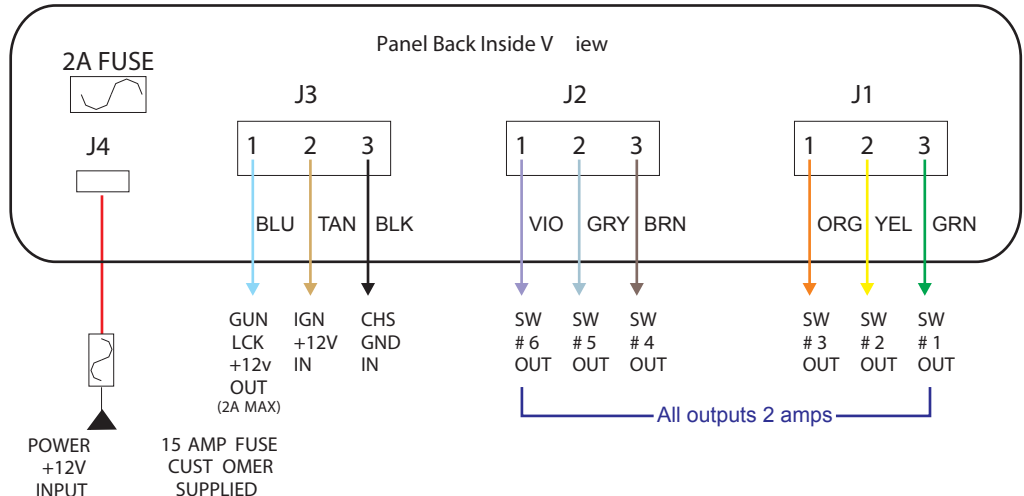
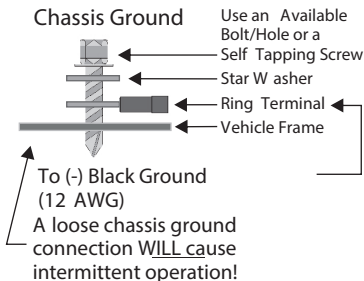

Auto-Walk-About Test

Enter Auto-Walk-About mode by holding down switches 1 & 6 at the same time for 5 seconds.

This test automatically turns each output (1 - 6) ON and OFF at a 5-second interval. The test runs for 120-seconds and can be exited at anytime by pressing any pursuit switch. The test can be reset by pressing any switch 1 - 6.

Panel Front View

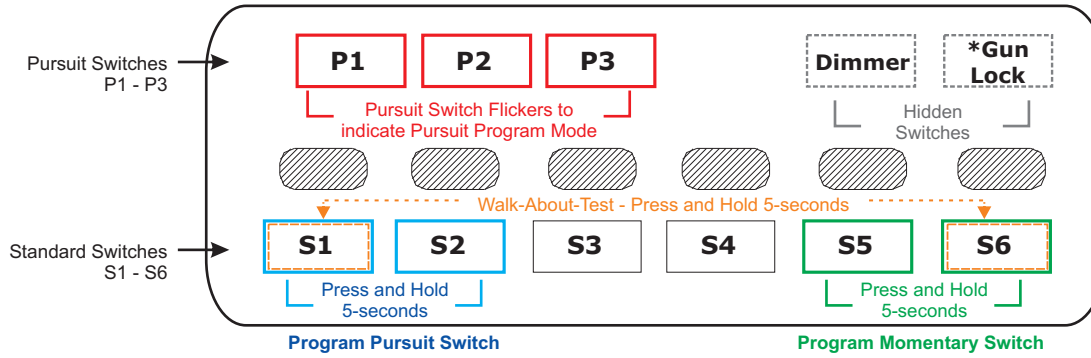

*The Gun Lock output wire may be hooked up to a flash pattern selector output (ie. on a light bar).
The flash patterns can then be selected by pushing the hidden switch button to cycle through the options.

ETSP993 Operation

1. Press any switch one (1) time to turn it On and press again to turn it OFF.
2. Press any Pursuit switch (See Program Pursuit Switches Section);
Switch back light turns ON and all associated standard switches (S1 - S6) turn ON.
3. Press *Gunlock switch. (*See note above to use Gunlock switch as light bar flash pattern selector.)
A momentary +12v signal is present at the gunlock output as long as button is pressed.
4. Dimmer Switch (Bright, Medium, Low & Off).
The brightness level can be changed (whenever no Pursuit Switches are active) by pressing dimmer switch to sequence through the levels. Brightness level will remain until panel is powered OFF and will return to default when powered back ON.
To save the chosen brightness level as the default, select desired brightness level then press and hold dimmer switch for 5-seconds. Display will flash ON and Off three times to indicate that the setting has been saved as the default.
Note: If the brightness level is set to OFF, the brightness will automatically be adjusted to LOW when any switches are ON.

Circuit Protection

Each standard switch output is protected by an electronic smart switch (2 Amp). Any time an over voltage or over temperature condition occurs, the output shuts OFF until condition is corrected. Once problem is corrected, function will automatically turn back ON.

- Notes:** There is no status indicator for an over voltage or over temperature condition. The power wire must be fused near battery at 15 Amps. The logic circuit is internally protected by a 2 Amp fuse.

Program Momentary Switch Options

All switches can be set as momentary. Additionally, Switch 6 can be set as a timed output of 1 to 25 seconds.

Special Note: Programming a Standard switch as momentary cancels any Pursuit switch association that may exist with that Standard switch.

To Enter Momentary Program Mode:

1. Press and hold switches S5 and S6 for 5-seconds.
All back lights will blink ON and OFF twice;
Pursuit switch P3 will start to flicker;
indicating panel is in Momentary Program Mode.
2. Press each switch that you want to program as momentary once.
Switches programmed as momentary will flicker.
3. To exit Momentary Program mode, press Pursuit switch P3 a second (2nd) time.
Note: All of the switch buttons will illuminate with a chase pattern to indicate the start of normal operation. If no button is pressed for 60-seconds, the panel will exit program mode automatically.

To Program Switch 6 as Timed Momentary

1. Repeat Step 1 above.
2. Press and hold Switch 6 for as long as you want the timer to run during operation. (Switch will flash for the timed number of seconds programmed)
3. Repeat Step 3 above.

Program Pursuit Switches

All of the Standard switches S1 through S6 can be associated with any of the Pursuit switches. Thus, when in normal operation, any combination of switches S1 - S6 can be activated just by pressing a Pursuit switch. Each Pursuit switch can be programmed with a different combination of S1 - S6.

Special Note: Programming a Standard switch as momentary cancels any Pursuit switch association that may exist with that switch.

To Enter Program Mode:

1. Press and hold switches S1 and S2 for 5-seconds.
All back lights will blink OFF then ON twice;
Pursuit switch P1 will start to flicker;
indicating panel is in Pursuit Program Mode.
2. Press each switch S1 - S6 you want associated with Pursuit Switch P1.
Selected switch will flicker;
indicating it has been associated with the Pursuit switch.
*Any number and combination of Standard switches may be associated with each Pursuit switch.
3. Press Pursuit switch P2 and repeat step 2 (Pursuit switch P2 will flicker).
4. Press Pursuit switch P3 and repeat step 2 (Pursuit switch P3 will flicker).
5. To exit Pursuit program mode, press the Pursuit switch that is flickering a second (2nd) time.
Note: All of the switch buttons will illuminate with a chase pattern to indicate the start of normal operation. If no button is pressed for 60-seconds, the panel will exit program mode automatically.

To review our Limited Warranty Statement & Return Policy for this or any SoundOff Signal product please visit our website at www.soundoffsignal.com and select the "Warranty & Returns" link along the left column of our home page. If you have questions regarding this product please contact Technical Services, Monday - Friday, 8 am to 5 pm at 1.800.338.7337, press #4 to skip the automated message. Questions or comments that do not require immediate attention may be emailed to techsupport@soundoffsignal.com.