

51 WINTHROP ROAD
 CHESTER, CONNECTICUT 06412-0684
 TELEPHONE: (860) 526-9504

⚠ WARNING: This product can expose you to chemicals including Lead which is known to the State of California to cause cancer and birth defects or other reproductive harm. For more information go to www.P65Warnings.ca.gov.

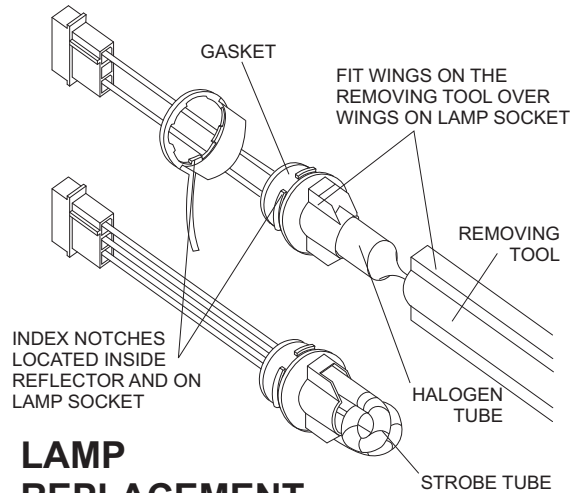

LAMP REPLACEMENT ...

WARNING! TO AVOID PERSONAL INJURY, **DO NOT** ATTEMPT TO REPLACE THE LAMP WITH FINGERS... USE THE LAMP REPLACEMENT TOOL INCLUDED IN KIT.

The lamp assembly is packed with the lamp replacement tool protecting the glass tube.

1. In some cases, the reflector may have to be removed for lamp replacement. If the lamp does not easily exit reflector, remove the reflector and check for obstructions.
2. Make sure gasket on lamp assembly is in place. Route the wire assembly through the reflector, and follow procedures as outlined in steps 6 and 7 on the other side of this page in lamp replacement instruction text.

IMPORTANT WARNING FOR SYSTEMS FEATURING STROBE LAMP HOLDER ASSEMBLIES!!!

THE STROBE LIGHT POWER SUPPLY IS A HIGH VOLTAGE DEVICE. DO NOT REMOVE STROBE LAMP HOLDER ASSEMBLY OR DISMANTLE STROBE LIGHT HEAD ASSEMBLY WHILE SYSTEM IS IN OPERATION. **WAIT 10 MINUTES AFTER TURNING OFF POWER BEFORE STARTING ANY WORK OR TROUBLE SHOOTING OF THE SYSTEM.**

51 WINTHROP ROAD
 CHESTER, CONNECTICUT 06412-0684
 TELEPHONE: (860) 526-9504

⚠ WARNING: This product can expose you to chemicals including Lead which is known to the State of California to cause cancer and birth defects or other reproductive harm. For more information go to www.P65Warnings.ca.gov.

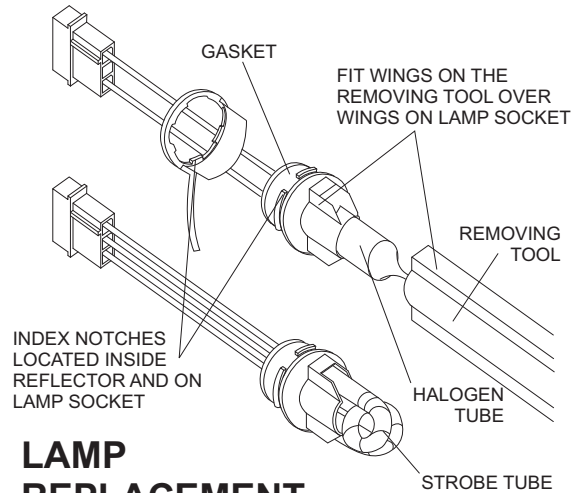

LAMP REPLACEMENT ...

WARNING! TO AVOID PERSONAL INJURY, **DO NOT** ATTEMPT TO REPLACE THE LAMP WITH FINGERS... USE THE LAMP REPLACEMENT TOOL INCLUDED IN KIT.

The lamp assembly is packed with the lamp replacement tool protecting the glass tube.

1. In some cases, the reflector may have to be removed for lamp replacement. If the lamp does not easily exit reflector, remove the reflector and check for obstructions.
2. Make sure gasket on lamp assembly is in place. Route the wire assembly through the reflector, and follow procedures as outlined in steps 6 and 7 on the other side of this page in lamp replacement instruction text.

IMPORTANT WARNING FOR SYSTEMS FEATURING STROBE LAMP HOLDER ASSEMBLIES!!!

THE STROBE LIGHT POWER SUPPLY IS A HIGH VOLTAGE DEVICE. DO NOT REMOVE STROBE LAMP HOLDER ASSEMBLY OR DISMANTLE STROBE LIGHT HEAD ASSEMBLY WHILE SYSTEM IS IN OPERATION. **WAIT 10 MINUTES AFTER TURNING OFF POWER BEFORE STARTING ANY WORK OR TROUBLE SHOOTING OF THE SYSTEM.**

51 WINTHROP ROAD
 CHESTER, CONNECTICUT 06412-0684
 TELEPHONE: (860) 526-9504

⚠ WARNING: This product can expose you to chemicals including Lead which is known to the State of California to cause cancer and birth defects or other reproductive harm. For more information go to www.P65Warnings.ca.gov.

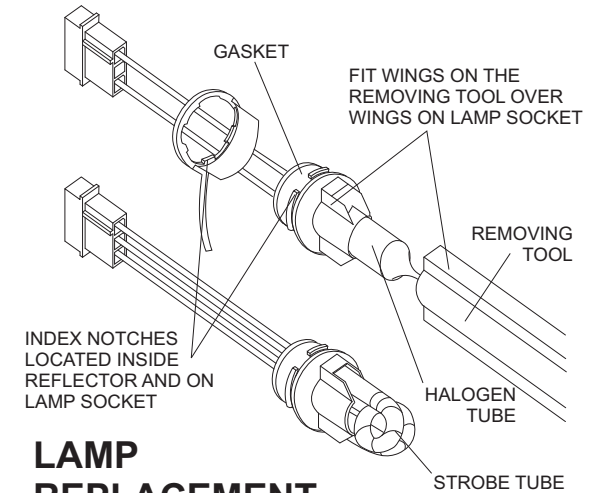

LAMP REPLACEMENT ...

WARNING! TO AVOID PERSONAL INJURY, **DO NOT** ATTEMPT TO REPLACE THE LAMP WITH FINGERS... USE THE LAMP REPLACEMENT TOOL INCLUDED IN KIT.

The lamp assembly is packed with the lamp replacement tool protecting the glass tube.

1. In some cases, the reflector may have to be removed for lamp replacement. If the lamp does not easily exit reflector, remove the reflector and check for obstructions.
2. Make sure gasket on lamp assembly is in place. Route the wire assembly through the reflector, and follow procedures as outlined in steps 6 and 7 on the other side of this page in lamp replacement instruction text.

IMPORTANT WARNING FOR SYSTEMS FEATURING STROBE LAMP HOLDER ASSEMBLIES!!!

THE STROBE LIGHT POWER SUPPLY IS A HIGH VOLTAGE DEVICE. DO NOT REMOVE STROBE LAMP HOLDER ASSEMBLY OR DISMANTLE STROBE LIGHT HEAD ASSEMBLY WHILE SYSTEM IS IN OPERATION. **WAIT 10 MINUTES AFTER TURNING OFF POWER BEFORE STARTING ANY WORK OR TROUBLE SHOOTING OF THE SYSTEM.**

HALOGEN AND STROBE ASSEMBLY INSTALLATION AND REPLACEMENT INSTRUCTIONS.

WARNING! TO AVOID PERSONAL INJURY, DO NOT ATTEMPT TO REPLACE THE LAMP WITH FINGERS... USE THE LAMP REPLACEMENT TOOL INCLUDED IN KIT.

1. Switch light system in the off mode.
2. Expose lamp by removing polycarbonate lens.
3. Place the lamp removing tool over the lamp. The wings on the tool should fit over the wings on the lamp holder assembly.
4. Twist the removing tool 1/8 turn counter-clockwise. Remove the burned out lamp from reflector and disconnect from the power cable or cable harness.

IMPORTANT NOTE!!! *When replacing lamp holder assemblies in a unit with more than one light head assembly, it is important to replace them one at a time. If more than one lamp is removed from the unit without being replaced, the connectors on the cable harness, lamp assemblies are connected to, will shift and will be inaccessible...*

5. If the reflector is dirty, use this opportunity to clean gently with a soft cloth or tissue moistened with isopropyl alcohol. Do not scrub, or use abrasive cleaners. If reflector is blemished, replace it to keep light output intensity at a high level.
6. Connect the new lamp to the power cable or cable harness, and line up the index notches on bulb socket and the index notches inside the reflector. Know that the lamp socket goes in one way only. Twist 1/8 turn clock wise.
7. Lamp tubes may be held and touched with the finger without any harm to the lamp tube. However wipe any finger prints from the glass bulb with a soft cloth or tissue. Reinstall polycarbonate lens.

HALOGEN AND STROBE ASSEMBLY INSTALLATION AND REPLACEMENT INSTRUCTIONS.

WARNING! TO AVOID PERSONAL INJURY, DO NOT ATTEMPT TO REPLACE THE LAMP WITH FINGERS... USE THE LAMP REPLACEMENT TOOL INCLUDED IN KIT.

1. Switch light system in the off mode.
2. Expose lamp by removing polycarbonate lens.
3. Place the lamp removing tool over the lamp. The wings on the tool should fit over the wings on the lamp holder assembly.
4. Twist the removing tool 1/8 turn counter-clockwise. Remove the burned out lamp from reflector and disconnect from the power cable or cable harness.

IMPORTANT NOTE!!! *When replacing lamp holder assemblies in a unit with more than one light head assembly, it is important to replace them one at a time. If more than one lamp is removed from the unit without being replaced, the connectors on the cable harness, lamp assemblies are connected to, will shift and will be inaccessible...*

5. If the reflector is dirty, use this opportunity to clean gently with a soft cloth or tissue moistened with isopropyl alcohol. Do not scrub, or use abrasive cleaners. If reflector is blemished, replace it to keep light output intensity at a high level.
6. Connect the new lamp to the power cable or cable harness, and line up the index notches on bulb socket and the index notches inside the reflector. Know that the lamp socket goes in one way only. Twist 1/8 turn clock wise.
7. Lamp tubes may be held and touched with the finger without any harm to the lamp tube. However wipe any finger prints from the glass bulb with a soft cloth or tissue. Reinstall polycarbonate lens.

HALOGEN AND STROBE ASSEMBLY INSTALLATION AND REPLACEMENT INSTRUCTIONS.

WARNING! TO AVOID PERSONAL INJURY, DO NOT ATTEMPT TO REPLACE THE LAMP WITH FINGERS... USE THE LAMP REPLACEMENT TOOL INCLUDED IN KIT.

1. Switch light system in the off mode.
2. Expose lamp by removing polycarbonate lens.
3. Place the lamp removing tool over the lamp. The wings on the tool should fit over the wings on the lamp holder assembly.
4. Twist the removing tool 1/8 turn counter-clockwise. Remove the burned out lamp from reflector and disconnect from the power cable or cable harness.

IMPORTANT NOTE!!! *When replacing lamp holder assemblies in a unit with more than one light head assembly, it is important to replace them one at a time. If more than one lamp is removed from the unit without being replaced, the connectors on the cable harness, lamp assemblies are connected to, will shift and will be inaccessible...*

5. If the reflector is dirty, use this opportunity to clean gently with a soft cloth or tissue moistened with isopropyl alcohol. Do not scrub, or use abrasive cleaners. If reflector is blemished, replace it to keep light output intensity at a high level.
6. Connect the new lamp to the power cable or cable harness, and line up the index notches on bulb socket and the index notches inside the reflector. Know that the lamp socket goes in one way only. Twist 1/8 turn clock wise.
7. Lamp tubes may be held and touched with the finger without any harm to the lamp tube. However wipe any finger prints from the glass bulb with a soft cloth or tissue. Reinstall polycarbonate lens.