

WHELEN[®]

ENGINEERING COMPANY INC.

51 Winthrop Road,
Chester, Connecticut 06412-0684
Phone: (860) 526-9504

Internet: www.whelen.com
Sales e-mail: autosale@whelen.com
Customer Service e-mail: custserv@whelen.com

Installation Guide: ION™ Lighthead Body Grommet

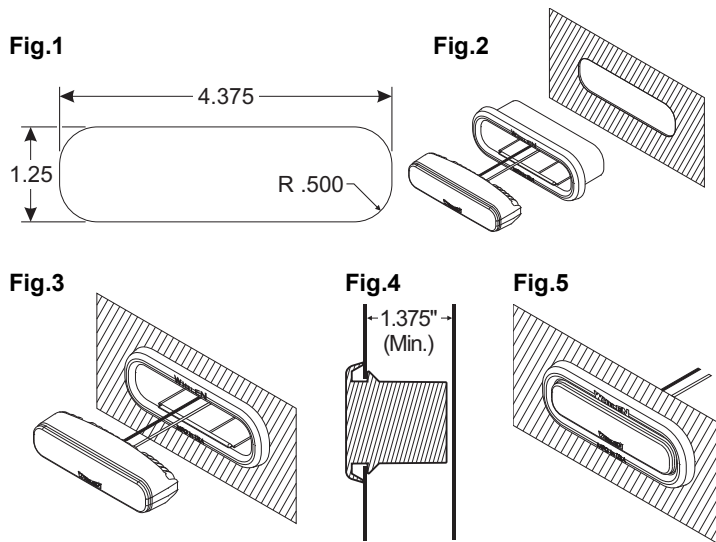

Installation:

1. Select an appropriate mounting surface (.187 max. thickness). Note that this installation requires a minimum 1.375" clearance behind the proposed mounting surface.
2. Cut a hole in the mounting surface using the dimensions shown in Fig.1. Deburr this opening before continuing.
3. Insert the body grommet into the opening so that it fully engages the mounting surface (Figs. 2, 3 & 4).
4. Feed the ION™ wires into the grommet and through the opening in the rear. Insert the ION™ lighthead into the body grommet until it is fully seated and properly retained (Fig.5).
5. Refer to the information included with the ION™ lighthead for wiring details.

©2011 Whelen Engineering Company Inc.
Form No.14523 (072811)

For warranty information regarding this product, visit www.whelen.com/warranty

WHELEN[®]

ENGINEERING COMPANY INC.

51 Winthrop Road,
Chester, Connecticut 06412-0684
Phone: (860) 526-9504

Internet: www.whelen.com
Sales e-mail: autosale@whelen.com
Customer Service e-mail: custserv@whelen.com

Installation Guide: ION™ Lighthead Body Grommet

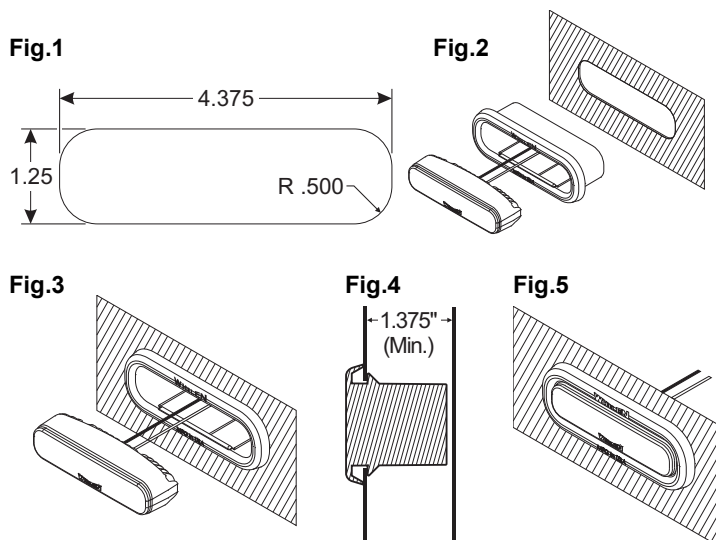

Installation:

1. Select an appropriate mounting surface (.187 max. thickness). Note that this installation requires a minimum 1.375" clearance behind the proposed mounting surface.
2. Cut a hole in the mounting surface using the dimensions shown in Fig.1. Deburr this opening before continuing.
3. Insert the body grommet into the opening so that it fully engages the mounting surface (Figs. 2, 3 & 4).
4. Feed the ION™ wires into the grommet and through the opening in the rear. Insert the ION™ lighthead into the body grommet until it is fully seated and properly retained (Fig.5).
5. Refer to the information included with the ION™ lighthead for wiring details.

©2011 Whelen Engineering Company Inc.
Form No.14523 (072811)

For warranty information regarding this product, visit www.whelen.com/warranty