



Clutch Pump Kit

700517

Dodge, 6.7L:D, 2011+, A/C, A Pump, 9 GPM Limit

BOLT PACKAGES:

BRACKET	716061 (Inc. items 14, 19, 20, 25, 26)
IDLER PULLEY	711451 (Inc. items 2, 17, 18)
CRANK PULLEY	None
TENSIONER	None
FAN SPACER	None

7-22-10	ISSUE DATE	C	2-3-12	REVISION DATE
---------	------------	---	--------	---------------

Item	Part No.	Description
1.	716060	Pump plate
2.	711449	Idler bushing
3.	711784	Intake adapter ring
4.	-----	-----
5.	-----	-----
6.	702054	Gasket
7.	740143	Idler pulley, DewEze
8.	*	Pump
9.	742009	Clutch
10.	-----	-----
11.	OEM	Air throttle body
12.	OEM	Intake tube
13.	-----	-----
14.	110820	M10 x 1.5 x 35 Bolt
15.	OEM	Idler pulley
16.	-----	-----
17.	110676	3/8 Flat washer
18.	110262	M10 x 1.5 x 75 Bolt
19.	110400	3/8-16 x 2 Bolt
20.	110484	M6 x 1.0 x 16 Bolt
21.	OEM	M6 Bolt
22.	-----	-----
23.	102059	Cable tie, .5" x 20"
24.	110425	3/8-16 x 1 1/4 Bolt
25.	110826	3/8 Nut
26.	110672	3/8 Lock washer
27.	742063	Belt, Micro-V K081298

FIG. 1
BELT DIAGRAM

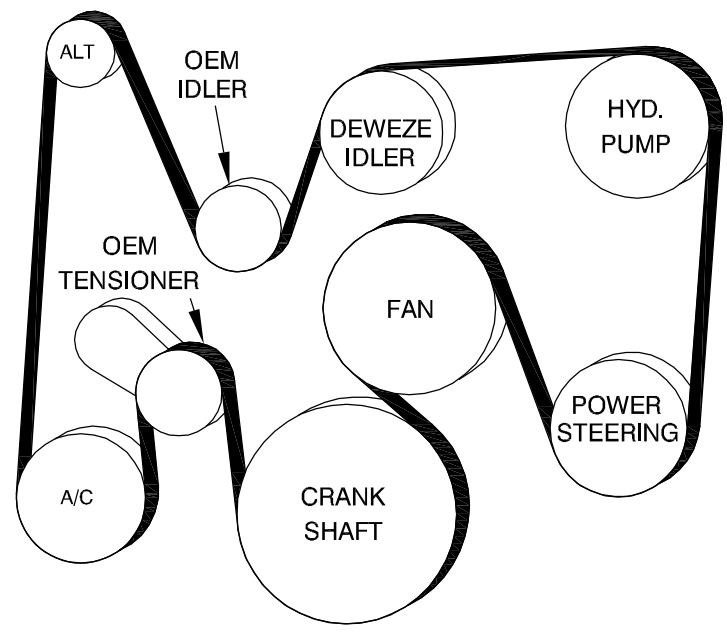

FIG. 2

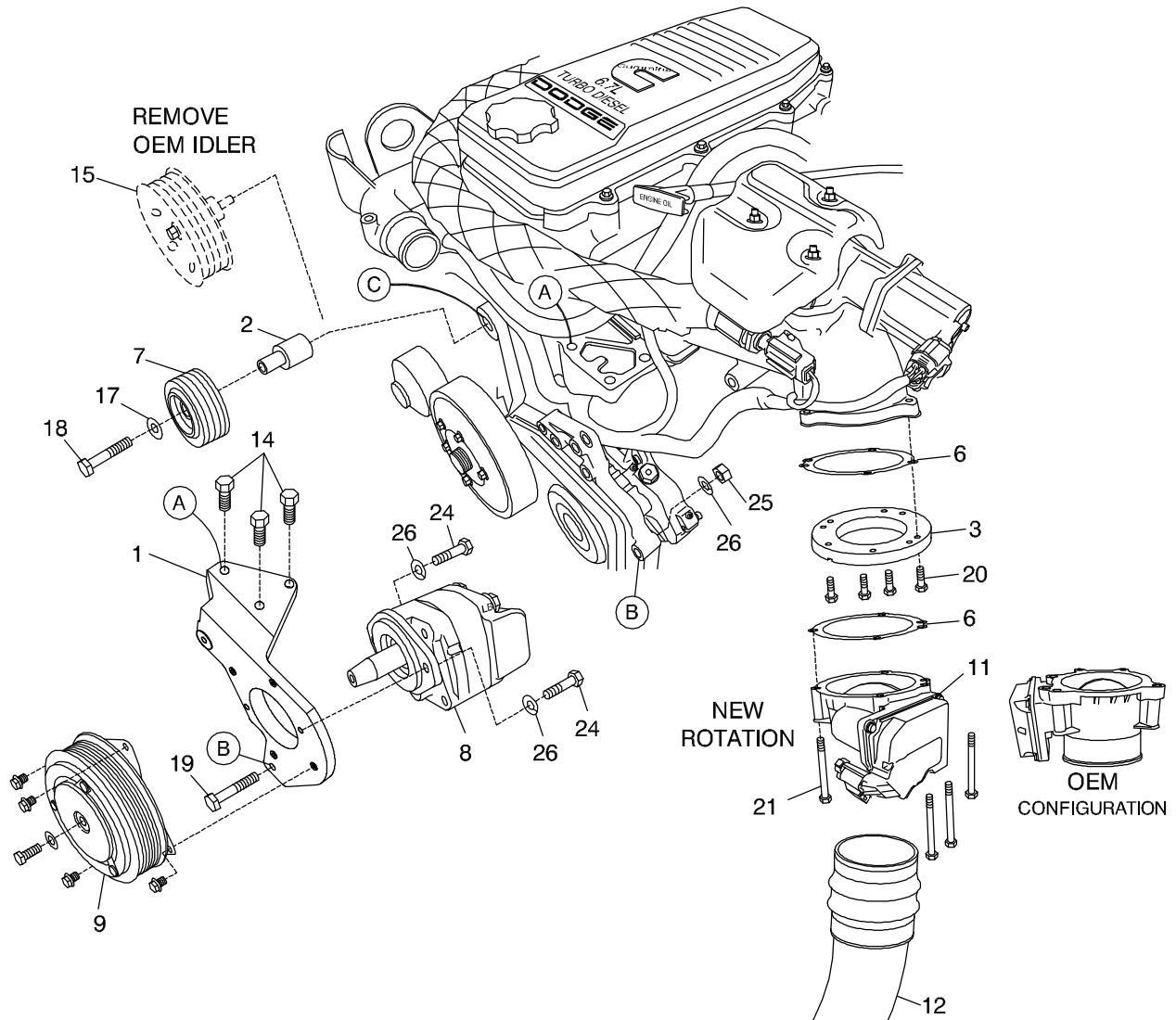

FIG. 3

ADAPTER RING ROTATION

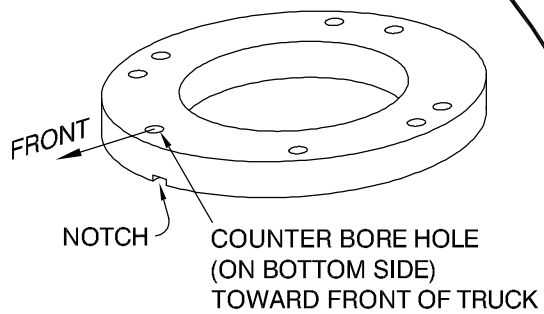

FIG. 4

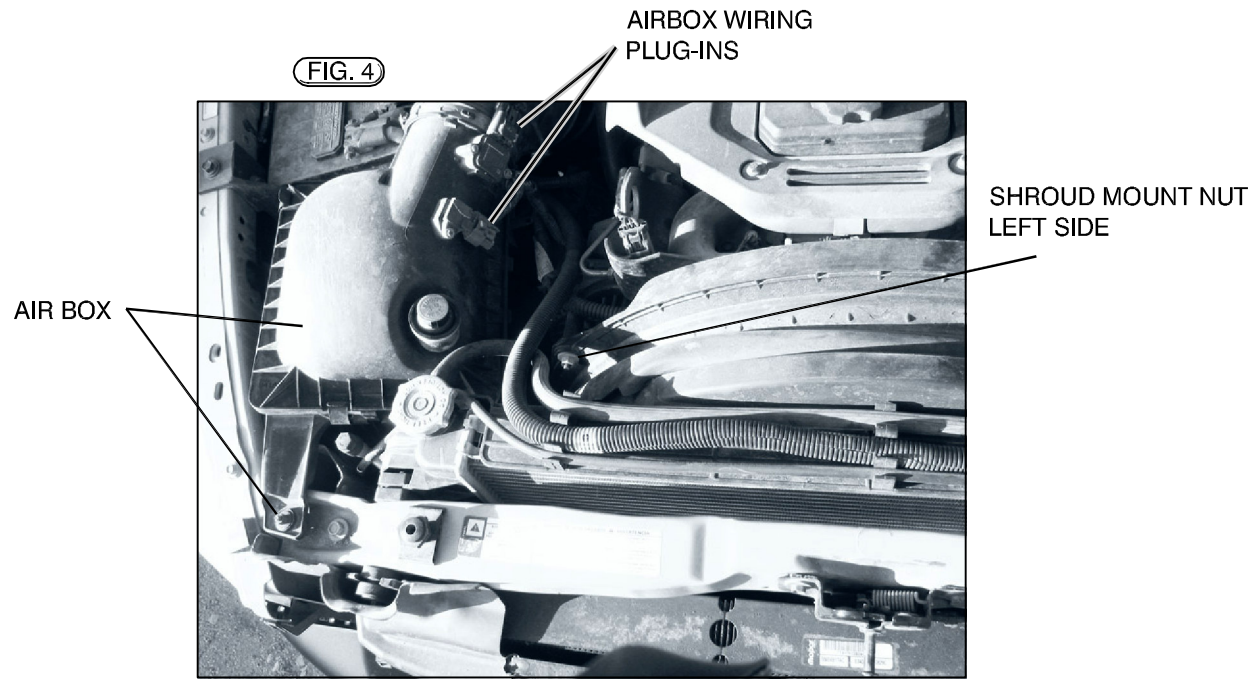

FIG. 5



FIG. 6

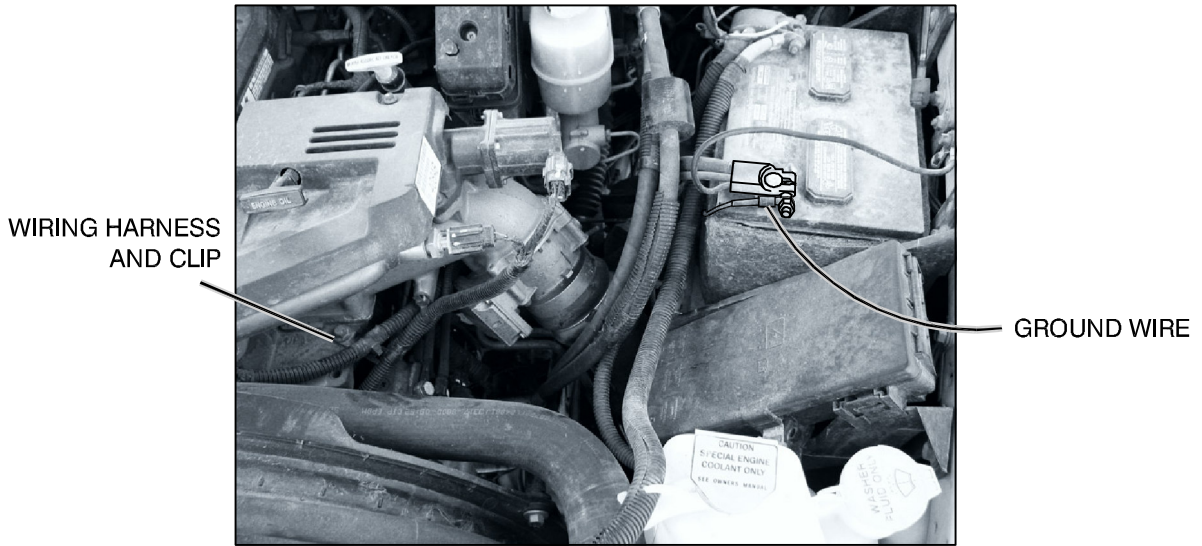
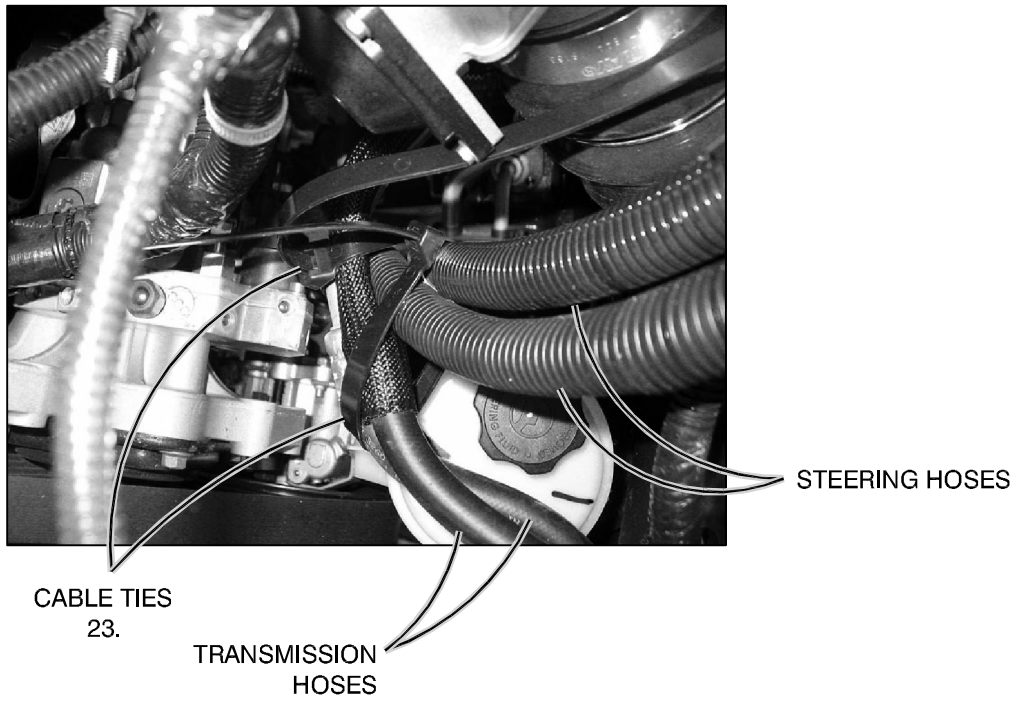

FIG. 7



DewEze Clutch Pump Kit 700517

Dodge 6.7L, 2011+, 15 HP Limit

INSTALLATION INSTRUCTIONS

Record Pump Model No. _____ and Serial No. _____ for future reference.

Left and right directions are standing in front of the truck looking at the engine.

1. The installation of this kit requires trained decision-making concerning clearances, tying components together, rerouting, or relocating OEM components, etc. It is impossible to describe all of the clearance and vibration points, etc. in the installation instructions. Therefore, the technician must exercise professional judgment to achieve the best quality installation.
2. Disconnect the battery.
3. Remove cover on the left front of the intercooler condenser. Fig. 5.
4. Remove the left and right fan shroud mounting nuts. Fig. 4, 6.
5. Disconnect wiring plug-ins from air box. Remove air box. Fig. 4.
6. Remove the top intercooler condenser bolts on the front of the truck. Fig. 5. Loosening the clamp, separate the intercooler tube (12) and the lower part of the air throttle body (11). Lift up the intercooler condenser and pull it toward you about 2" to get the tube away from the throttle body. Remove the OEM gasket from the upper portion. Replace with a new gasket (6). Using four M6 x 16 bolts (20) mount the adapter ring (3) to the upper portion of the throttle body still attached to the truck with the counterbore holes facing down. The small notch at the outside diameter beside one of the counterbore holes indicates that hole points toward the front of the truck. Fig. 3.
7. Rotate the lower throttle body as shown in Fig. 2. Place the new gasket (6) on top of the lower throttle body and mount to the adapter ring using the OEM bolts (21). Put the condenser back into position, guiding the intercooler tube back onto the throttle body. Tie the transmission hoses to the power steering hoses for clearance using the cable ties (23) as in Fig. 7. Gently bend the steel hose ends slightly if needed to keep the hoses away.
8. Remove the OEM belt.
9. Remove the OEM grooved idler pulley (15) from the front of the engine at Location C. In its place, mount the DewEze grooved idler pulley (7) with the idler bushing (2), M10 x 75 bolt (18) and a 3/8 flat washer (17).
10. Install DewEze belt (27) on the OEM pulleys. It is easier to access the pulleys when the shroud can be pulled away and before the pump is installed.
11. Disconnect the ground wire attached to outside of battery post clamp on right side battery and reroute on top of existing truck hoses so pump hoses will go under wire. Reconnect. Fig. 6.
12. Mount the pump (8) to the back of the pump plate (1) with two 3/8 x 1 1/4 bolts (24) and two 3/8 flat washers (17). Mount the hose adapters to the pump.
13. Mount the clutch coil (9a) to the pump bracket with four 1/4 x 1/2 flange bolts (9b). Mount the clutch pulley (9c) to the pump shaft with the 5/16 x 1 1/4 bolt (9d) and heavy flat washer (9e) making sure the key is in place on the shaft.
14. Run the hoses into the engine compartment. Pull them out far enough to attach them to the pump. Attach the top of the pump bracket (1) to the engine at Location A using three M10 x 40 bolts (14). Attach the bottom of the pump bracket to the power steering bracket at

Location B with the 3/8 x 2 bolt (19), and the 3/8 lock washer (26) and 3/8 nut (25) on the back.

15. Finish installing the belt (27) onto the pump pulley as shown in the diagram (Fig. 1).
16. Install air box. Install intercooler cover. Connect battery.
17. Run the engine and check for any clearance or alignment problems. Re-examine the power steering lines for clearance as the engine torques. Adjust as needed.