



**PRODUCT DATA SHEET**

P/N: **BKM**  
**BUCKET MOUNT**



**FEATURES**

- Easy to use wall mounted bucket storage
- Buckets drop through and are supported by wire loop
- Fits most buckets 3.5-5 gallon in size and most heights
- Made from strong durable materials
- Folds down and out of the way when bucket is removed
- Compact attachment point
- Compatible with PAC Trac aluminum boards
- Compatible with ROPS brackets for use on roll bars

**SPECIFICATIONS**

P/N	WT.	MAX LOAD	FIT	FLAME TOXICITY CHEMICAL
BKM	0.4 LB	25lbs	STD BUCKET	FAIR

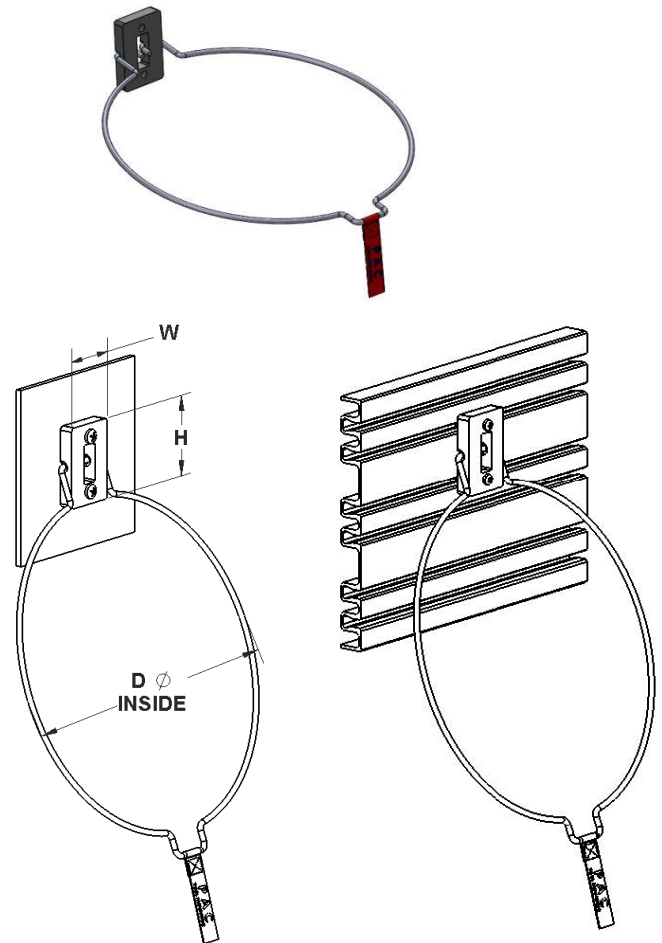

Dimensions: 1-7/8" W X 2-3/4" H X 11-1/4" D

Performance Advantage Company

Lancaster, New York

www.pactoolmounts.com

888-514-0083

REFERENCE	QTY	REMARKS	PROJECT
			LOCATION
			BUYER
			DEALER
			BUILDER
			SUBMITTED BY:
			DATE:

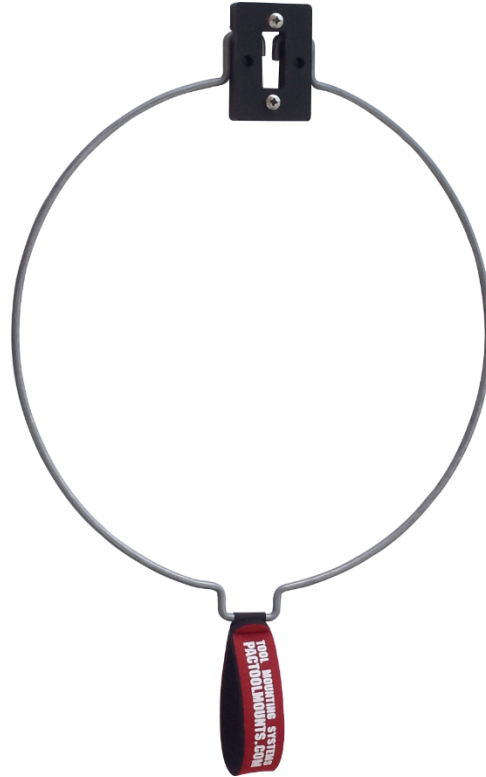

- Easy to use wall mounted bucket storage
- Buckets drop through and are supported by wire loop
- Fits most buckets 3.5-5 gallon in size and most heights
- Made from strong durable materials
- Folds down and out of the way when bucket is removed
- Compact attachment point
- Compatible with PAC Trac aluminum boards
- Compatible with ROPS brackets for use on roll bars

