



OWNER'S MANUAL

12 SERIES LCG CARRIERS GENERATION II

INSTALLATION, OPERATION, MAINTENANCE & PARTS

NOTE: MANUAL including SPECIFICATIONS, subject to change without notice
All ratings specified are based on structural factors only,
not vehicle capacities or capabilities.



8503 Hilltop Drive
Ooltewah, Tennessee 37363

Phone (423) 238-4171 • FAX (423) 238-5371

0540026
06/09
PRICE \$25.00

LIMITED WARRANTY

MILLER INDUSTRIES TOWING EQUIPMENT INC., hereinafter referred to as MILLER, warrants to the original purchaser that each new MILLER Carrier will be free from defects in material and workmanship for a period of one (1) year from the date of purchase. The purchaser must promptly notify MILLER in writing of any failure in material or workmanship. In no event shall such notification be received by MILLER later than twelve (12) months from date of delivery.

The obligation under this warranty, statutory or otherwise, is limited to the repair or replacement at our factory, or at a point designated by us, of such part or parts as shall appear to us upon inspection to be defective in material or workmanship. New or remanufactured parts will be used for any replacement.

This warranty does not obligate MILLER to bear the cost of labor or transportation charges in connection with the replacement or repair of any parts found to be defective, nor shall it apply to a product upon which repairs or alterations have been made unless authorized by us.

MILLER shall in no event be liable for any incidental or consequential damages or contingent arising out of the failure of any parts or products to operate properly. NO IMPLIED, EXPRESS, OR STATUTORY WARRANTY OTHER THAN STATED HEREIN IS MADE OR AUTHORIZED TO BE MADE BY OR FOR US, INCLUDING, BUT NOT LIMITED TO, THE IMPLIED WARRANTIES OF MERCHANTABILITY AND FITNESS FOR A PARTICULAR PURPOSE.

MILLER makes no warranty, express or implied, as to finished products manufactured or supplied by another manufacturer or supplier by MILLER to purchaser, including, but not limited to, any vehicle to which a MILLER product may be affixed or accessories or wire rope (cable), and expressly disclaims any implied warranties of merchantability or fitness for a particular purpose as to such equipment or products. This language shall in no way affect or diminish the rights of purchaser to rely on such warranties as are extended by such manufacturers or suppliers.

MILLER, whose policy is one of continuous improvement, reserves the right to improve its product through changes in design or materials as it may deem desirable without being obligated to incorporate such changes in products of prior manufacture.

IT IS EXPRESSLY UNDERSTOOD THAT THERE IS NO IMPLIED WARRANTY THAT MILLER CARRIERS SHALL BE FIT FOR THE PURPOSE OF LIFTING OR MOVING PERSONS OR OTHER IMPROPER USE. THIS WARRANTY IS NOT TRANSFERABLE.



8503 Hilltop Drive
Ooltewah, Tennessee 37363
Telephone (423) 238-4171

SERIAL NUMBER

OWNER, USER AND OPERATOR:

Miller Industries appreciates your choice of our car carrier for your application. Our number one priority is user safety which is best achieved by our joint efforts. We feel that you can make a major contribution to safety if you, as the equipment owner and operator:

- 1. Comply with Federal, State, and Local Regulations.**
- 2. Read, Understand, and Follow the Instructions in this Manual.**
- 3. Use Good, Safe Work Practices in a Common Sense Way.**
- 4. Only have Authorized and Trained Operators running the Car Carrier.**

Also contained in this manual is a Parts Section for your Car Carrier. Use of other than Factory or Factory Authorized Parts will render the Warranty void.

TABLE OF CONTENTS



The operator must read and understand all instructions in this manual before operating the car carrier.

It is assumed by Miller Industries that the Owner/Operator has thorough knowledge of the accepted and lawful retrieval and towing methods as dictated by his city, county or state. Miller Industries rejects any liability claim that may result from the incorrect or unlawful application of its equipment.

Section I - SAFETY PRECAUTIONS..... I-1 thru I-5

Section II - SPECIFICATIONS..... II-1 thru II-4

Section III - OPERATIONAL FUNCTIONS..... III-1 thru III-4

Section IV - OPERATING INSTRUCTIONS

CARRIER..... IV-1 thru IV-13

WHEEL LIFT..... IVA-1 thru IVA-30

Section V - MAINTENANCE..... V-1 thru V-8

MAINTENANCE RECORD..... V-7 thru V-8

Section VI - PARTS..... VI-1 thru VI-45

ALUMINUM BED ASSEMBLY FULL SIDE.....VI-2 & VI-3

ALUMINUM BED ASSEMBLY REMOVABLE RAIL.....VI-4 & VI-5

STEEL BED ASSEMBLY TUBE SIDE.....VI-6 & VI-7

STEEL BED ASSEMBLY REMOVABLE TUBE RAIL.....VI-8 & VI-9

SUBFRAME ASSEMBLY.....VI-10 & VI-11

TAIL LIGHT COMPONENTS.....VI-12 & VI-13

WHEEL LIFT & SLIDE-IN TIRE RESTRAINT ASS'Y.....VI-14 & VI-15

OPTIONAL 3-WAY PIVOT L-ARM ASSEMBLY.....VI-16

AUTOGRIP II COMPONENTS.....VI-17 thru VI-20

DOCK STABILIZER.....VI-21

CONTROL STATION.....VI-22

CONTROL & CROSSROD ASSEMBLY.....VI-23 & VI-24

HYDRAULICS.....VI-25

WINCH CLUTCH CONTROL.....VI-26

TABLE OF CONTENTS (cont'd)

Section VI - PARTS (cont'd)

RAMSEY 234 HYDRAULIC WINCH.....	VI-27 & VI-28
CABLE TENSIONER ASSEMBLY.....	VI-29
CABLE ROLLER ASSEMBLY.....	VI-30
BED LOCK ASSEMBLY.....	VI-31
OPTIONAL POWER UP DASHBOARD PANEL.....	VI-32
LIGHT KIT.....	VI-33 thru VI-35
OPTIONAL LIGHTING ACCESSORIES.....	VI-36
MANUAL SLIDEWINDER (LONG TRACK).....	VI-37

Section VII - INSTALLATION INSTRUCTIONS..... VII-1 thru VII-28

Section VIII - SCHEMATICS

ELECTRICAL	VIII-1
HYDRAULIC	VIII-2
AUTOGRIP	VIII-3
SIDE PULLER	VIII-4 & VII-5

Section VI - PARTS

This Section is provided by the manufacturer for the purpose of ordering any component part of the **12 Series LCG Carrier** that may be required when part replacement is necessary. Be certain to use only original equipment replacement parts for warranty purposes as well as for keeping your **12 Series LCG Carrier** in its original state and optimum operating capacities.

When ordering replacement or spare parts be sure to provide the following information to your carrier manufacturer authorized representative.

1. **Manual Number & Date of Publication**
2. **Manual Page Number**
3. **Page Title**
4. **Reference Number of Part Desired**
5. **Part Number**
6. **Part Description**
7. **Quantity of Part Desired**

Providing this information will help ensure that the correct parts will be delivered to you in an expedient manner without delay. Should additional information be required for repair or replacement of certain components, contact **Miller Industries, Hermitage, PA, Phone: 724-981-3328, FAX 724-981-5260.**

The Manufacturer reserves the right, without notice or obligation, to improve or modify their products, which may change the specifications, models and feature availability.

Section VI - PARTS

ALUMINUM BED ASSEMBLY REMOVABLE RAIL

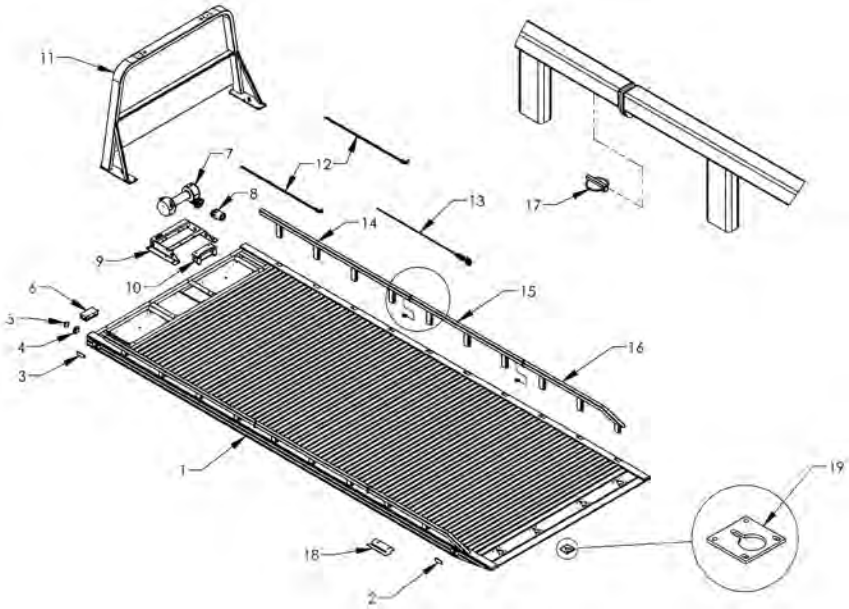

Section VI - PARTS

ALUMINUM BED ASSEMBLY REMOVABLE RAIL

REF. NO.	NO. REQ'D	PART NUMBER	DESCRIPTION
1	1	3018212XX	S12 LCG G2 AL BED WELDMENT
2	2	0308359	LED MARKER LIGHT, RED, RECTANGLE
3	2	0311516	2-1/2" MARKER LIGHT GROMMET
4	2	0311513	2-1/2" AMBER MARKER LIGHT
5	2	0311512	2-1/2" RED MARKER LIGHT
6	1	0303385	10 POST JUNCTION BOX
7	1	0300250	RAMSEY 8000 LB WORM GEAR
8	1	0306157	WINCH MOTOR
9	1	0801482	WINCH MOUNTING FRAME WELDMENT
10	1	0805037	ROLLER GUIDE ASSEMBLY
11	1	0809558-XX	CAB PROTECTOR
12	2	0302493	FRONT SAFETY CHAIN ASSEMBLY - 5/16 x 8"
13	1	0301669	WINCH CABLE ASSEMBLY
14	2	34460XXF	REMOVABLE TUBE RAIL FRONT (SEE CHART)
15	2	346071M	REMOVABLE TUBE RAIL 3 POST MIDDLE
16	2	3406064	REMOVABLE TUBE RAIL REAR
17	4	84712	LYNCH PIN - 7/16 x 1-15/16
18	1	33813	ANTI-TILT PLATE
19	4	0707239	CHAINLOCK REINFORCEMENT PLATE

Section VI - PARTS

STEEL BED ASSEMBLY REMOVABLE TUBE RAIL

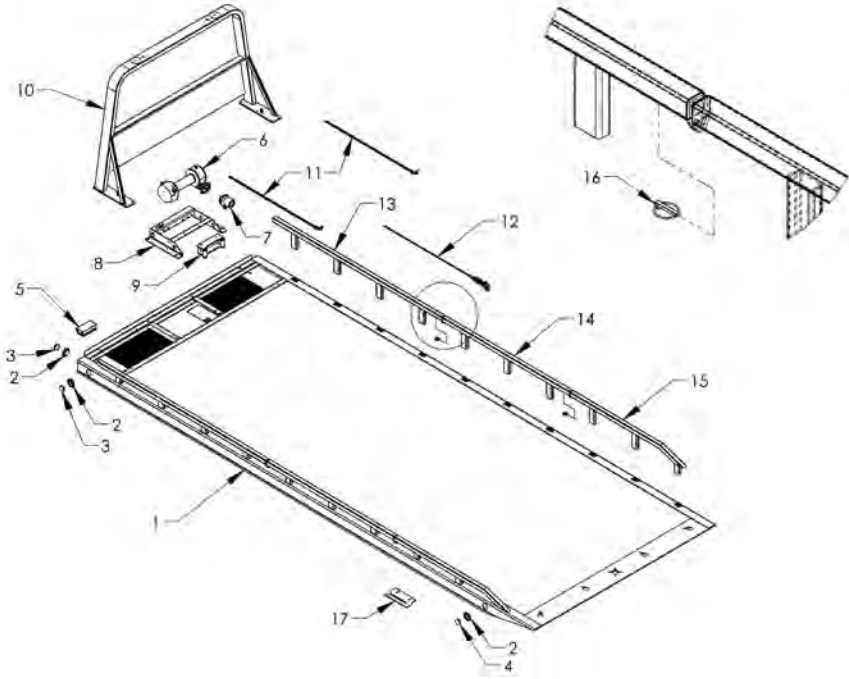

Section VI - PARTS

STEEL BED ASSEMBLY REMOVABLE TUBE RAIL

REF. NO.	NO. REQ'D	PART NUMBER	DESCRIPTION
1	1	301284122XXX	S12 LCG G2 ST BED WELDMNT
2	6	0311516	2-1/2" MARKER LIGHT GROMMET
3	4	0311513	2-1/2" AMBER MARKER LIGHT
4	2	0311512	2-1/2" RED MARKER LIGHT
5	1	0303385	10 POST JUNCTION BOX
6	1	0300250	RAMSEY 8000 LB WORM GEAR
7	1	0306157	WINCH MOTOR
8	1	0801480	WINCH MOUNTING FRAME WELDMNT
9	1	0805037	ROLLER GUIDE ASSEMBLY
10	1	0809558-XX	CAB PROTECTOR
11	2	0302493	FRONT SAFETY CHAIN ASSEMBLY - 5/16 x 8"
12	1	0301669	WINCH CABLE ASSEMBLY
13	2	34460XXF	REMOVABLE TUBE RAIL FRONT (SEE CHART)
14	2	346071M	REMOVABLE TUBE RAIL 3 POST MIDDLE
15	2	3406064	REMOVABLE TUBE RAIL REAR
16	4	84712	LYNCH PIN - 7/16 x 1-15/16
17	1	33813	ANTI-TILT PLATE

Section VI - PARTS

REMOVABLE TUBE SIDE RAILS

BED LENGTH	REMOVABLE RAIL COMBINATIONS
17.5 TO 18.5 FT	
19 TO 20.5 FT	
21 TO 22 FT	

REF	PART #	DESCRIPTION	QPU
1	346049F	FRONT REMOVABLE TUBE RAIL - 2 POST	SEE CHART
2	346071F	FRONT REMOVABLE TUBE RAIL - 3 POST	SEE CHART
3	346095F	FRONT REMOVABLE TUBE RAIL - 4 POST	SEE CHART
4	346071M	MIDDLE REMOVABLE TUBE RAIL - 3 POST	SEE CHART
5	346064	REAR REMOVABLE TUBE RAIL - 3 POST	SEE CHART

Section VI - PARTS REMOVABLE BLADE SIDE RAILS

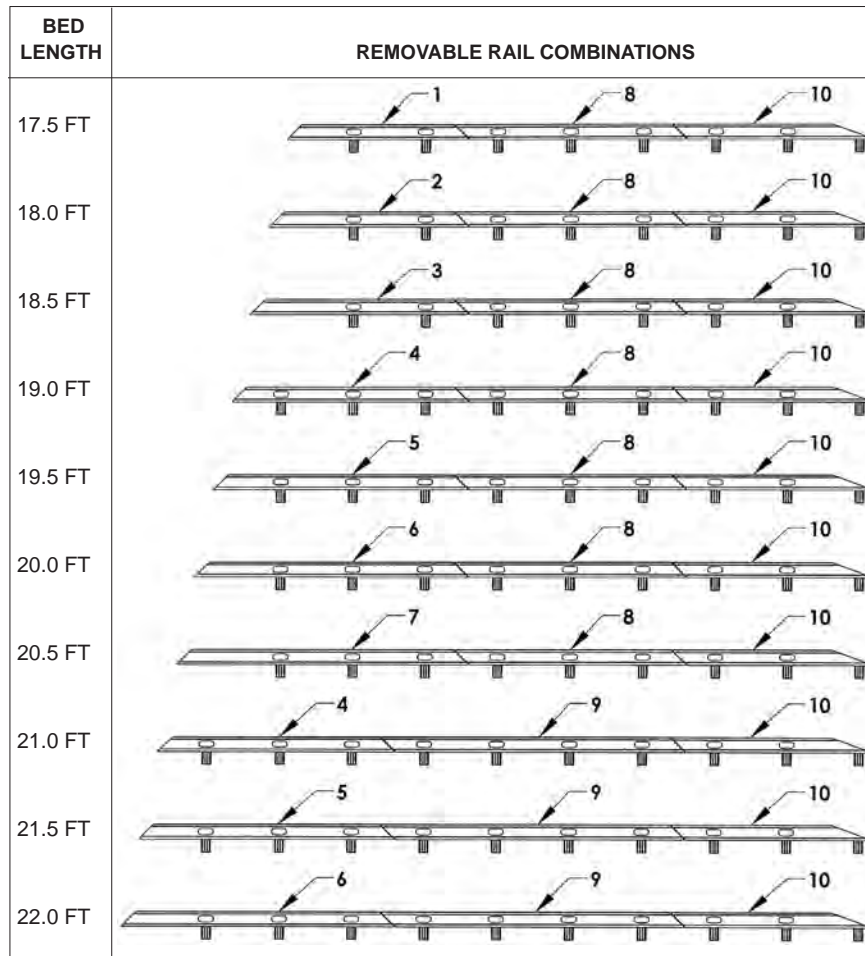

REF	PART #	DESCRIPTION	QPU
1	34B060FL	FRONT REMOVABLE BLADE RAIL - 2 POST	SEE CHART
2	34B066FL	FRONT REMOVABLE BLADE RAIL - 2 POST	SEE CHART
3	34B072FL	FRONT REMOVABLE BLADE RAIL - 2 POST	SEE CHART
4	34B078FL	FRONT REMOVABLE BLADE RAIL - 3 POST	SEE CHART
5	34B084FL	FRONT REMOVABLE BLADE RAIL - 3 POST	SEE CHART
6	34B090FL	FRONT REMOVABLE BLADE RAIL - 3 POST	SEE CHART
7	34B096FL	FRONT REMOVABLE BLADE RAIL - 3 POST	SEE CHART
8	34B072ML	MIDDLE REMOVABLE BLADE RAIL - 3 POST	SEE CHART
9	34B096ML	MIDDLE REMOVABLE BLADE RAIL - 4 POST	SEE CHART
10	34B064RL	REAR REMOVABLE BLADE RAIL - 3 POST	SEE CHART

Section VI - PARTS

12 SERIES LCG SUBFRAME COMPONENTS

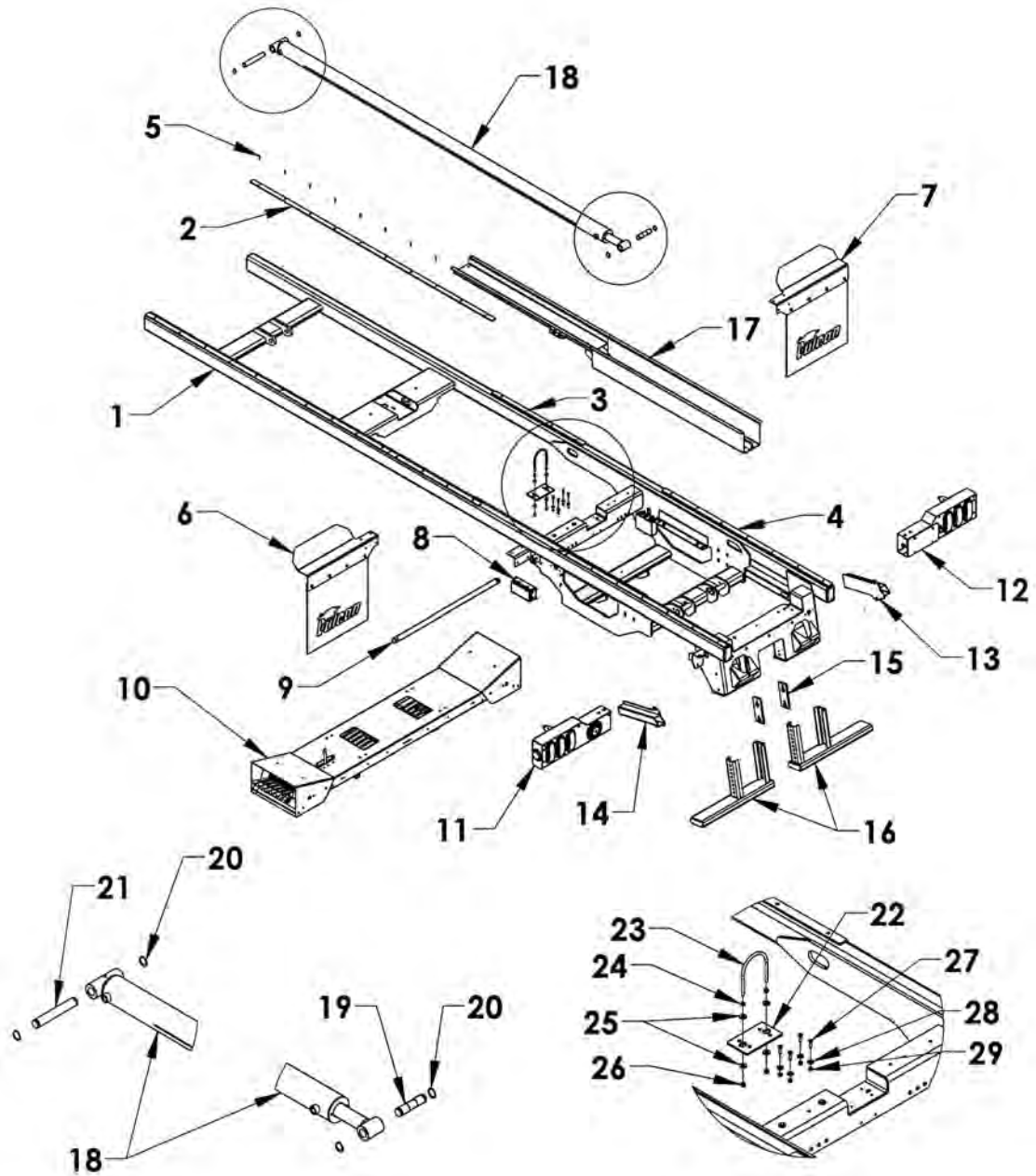

Section VI - PARTS

12 SERIES LCG SUBFRAME ASSEMBLY

REF NO.	NO REQ'D	PART NUMBER	DESCRIPTION
1	1	0809839	G2 SUBFRAME WELDMENT
2	2	0308928-96	SUBFRAME BEARING PAD 5/16 x 1-1/2 x 96
3	2	0308928-36	SUBFRAME BEARING PAD 5/16 x 1-1/2 x 36
4	2	0308928-66	SUBFRAME BEARING PAD 5/16 x 1-1/2 x 66
5	40	81007	BOLT 1/4-20 UNC x 1 - COUNTERSUNK TORX ST
6	1	0751024L	ALUM SPLASH GUARD LEFT REAR RIGHT FRONT
7	1	0751024R	ALUM SPLASH GUARD RIGHT REAR LEFT FRONT
8	1	0303385	10 POST JUNCTION BOX
9	1	0750952	S12 LCG HINGE PIN
10	1	183126	6-SPOOL CONTROL STATION
11	1	0940326L	LCG G2 TAIL LIGHT HOUSING GROUP - LEFT
12	1	0940326R	LCG G2 TAIL LIGHT HOUSING GROUP - RIGHT
13	1	0809287R	L-ARM STORAGE TUBE - RIGHT
14	1	0809287L	L-ARM STORAGE TUBE - LEFT
15	2	0750409	STABILIZER WHEEL LIFT GUIDE PAD
16	2	160525	STABILIZER EXTENSION STAND-LOW PROFILE
17	1	0809824	LCG DUAL BAY HOSE TRAY
18	1	72A35120	SLIDEBACK CYLINDER 3.5 BORE x 120 STROKE
19	1	32117	SLIDEBACK CYLINDER MOUNTING PIN 1.230
20	4	86125E	1-1/4 SNAP RING - EXTERNAL
21	1	13302010	S12 LCG SLIDEBACK CYLINDER MOUNTING PIN
22	1	0751223	LCG 12/16/20 S/B CYLINDER SUPPORT PAD
23	1	81286	U-BOLT 3/8-16 UNC
24	2		3/8 HEX NUT
25	4		3/8 FLAT WASHERT
26	2		NYLON LOCK NUT 5/16-18 UNC
27	4	81121	BOLT 5/16-18 UNC - ALLEN COUNTERSUNK
28	4		5/16 FLAT WASHER
29	4		NYLON LOCK NUT 5/16-18 UNC

Section VI - PARTS

12 SERIES LCG TAIL LIGHT COMPONENTS

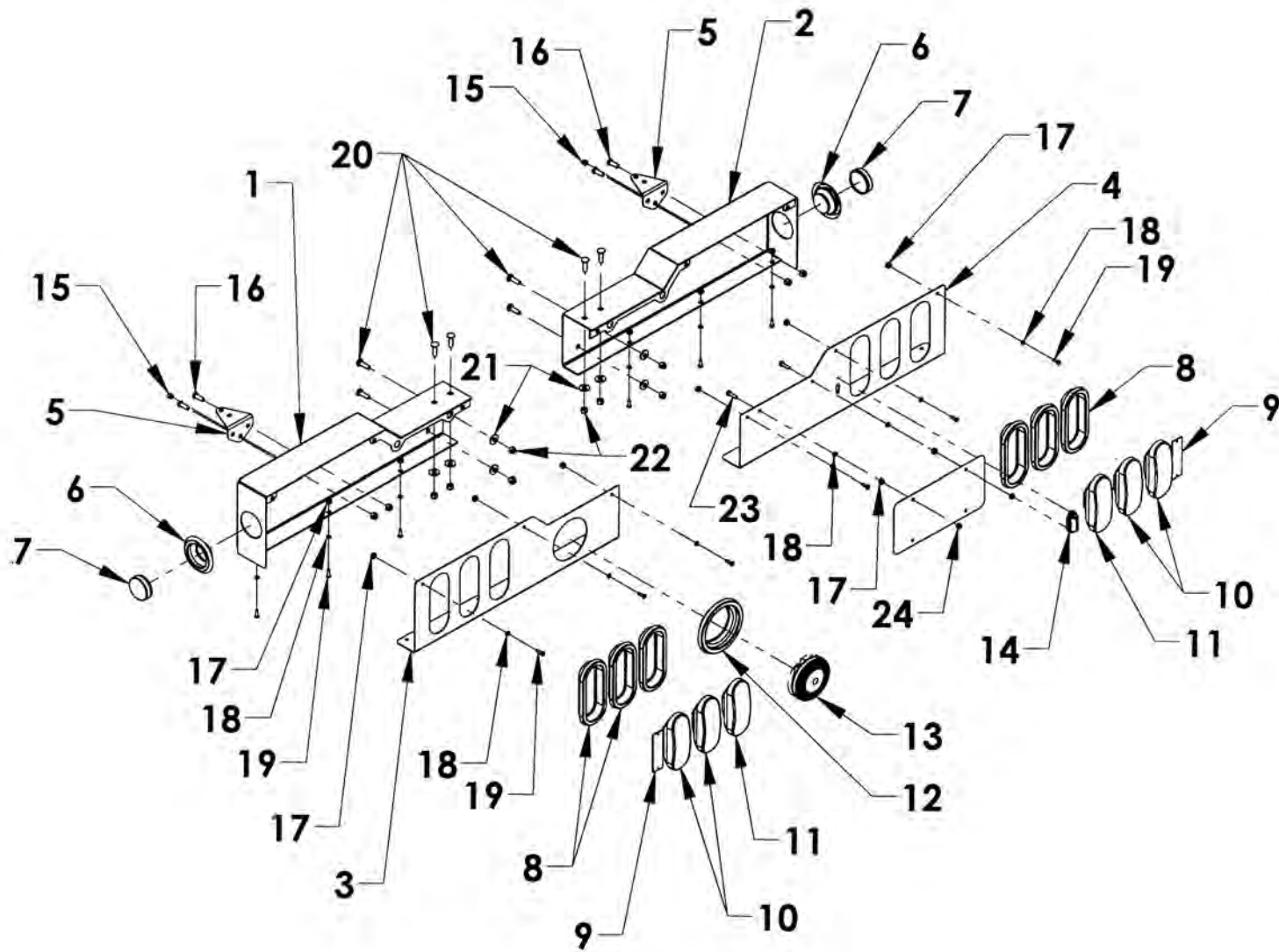

Section VI - PARTS

12 SERIES LCG GEN2 TAIL LIGHT COMPONENTS

REF. NO.	NO. REQ'D	PART NUMBER	DESCRIPTION
1	1	0809517L	TAIL LIGHT HOUSING WELDMENT - LEFT
2	2	0809517R	TAIL LIGHT HOUSING WELDMENT - RIGHT
3	1	0751893L	12/16/20 LCG TAIL LIGHT BEZEL - LEFT G2
4	1	0751893R	12/16/20 LCG TAIL LIGHT BEZEL - RIGHT G2
5	2	0750672	WORK LIGHT MOUNTING BRACKET
6	2	0311516	2-1/2 IN. MARKER LIGHT GROMMET
7	2	0311512	2-1/2 IN. RED MARKER LIGHT
8	4	0311503	6 IN. OVAL GROMMET
9	4	0311529	REFLECTOR - RED 4.375 x 1.5
10	2	0311498	6 IN. OVAL RED LIGHT
11	2	0311500	6 IN. OVAL REVERSE LIGHT
12	1	0311528	BACK UP ALARM GROMMET
13	1	0306385	BACK UP ALARM
14	1	0311525	LICENSE PLATE LIGHT
15	2	0306050	TAIL LIGHT WIRE GROMMET
16	4	-	BOLT, HHCS 3/8-16 UNC x 1
17	14	-	LOCK WASHER - 1/4
18	12	-	BOLT, RHMS 1/4-20 UNC x 3/4
19	14	-	HEX NUT 1/4-20 UNC
20	8	-	BOLT, CARRIAGE 3/8-16 UNC x 1-1/4 SS
21	8	-	FLAT WASHER - 3/8
22	12	-	NYLON LOCK NUT 3/8-16 UNC
23	2	-	BOLT, HHCS 1/4-20 UNC x 1
24	2	-	NYLON LOCK NUT 1/4-20 UNC

Section VI - PARTS
4,000 LB.WHEEL LIFT

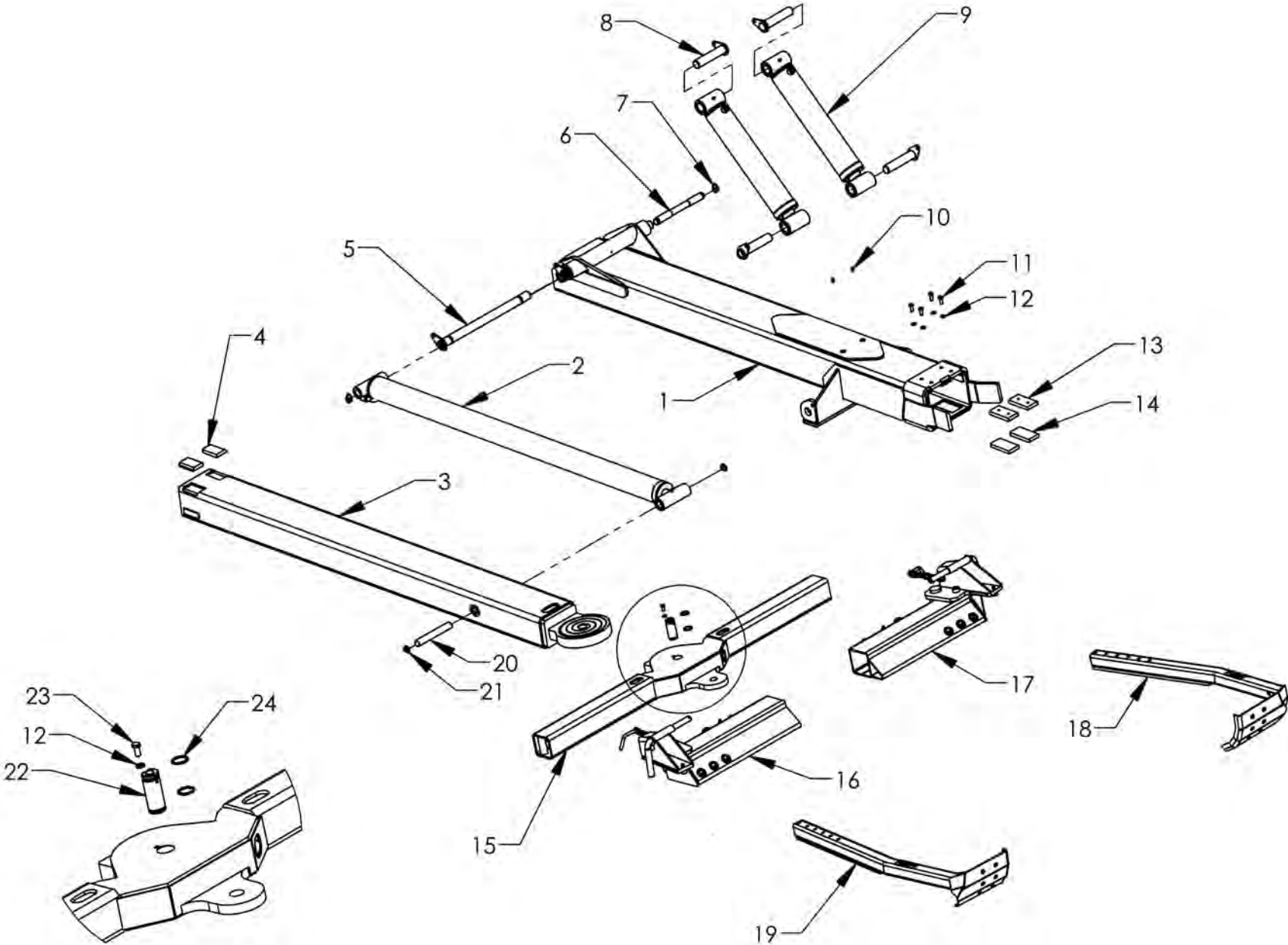

Section VI - PARTS

4,000 LB. WHEEL LIFT - GEN 2

REF. NO.	NO. REQ'D	PART NUMBER	DESCRIPTION
1	1	0809791	WHEEL LIFT OUTER BOOM TUBE - 4K
2	1	72A30054	WHEEL LIFT EXTEND CYLINDER 3.0 x 54
3	1	0809802	4K INNER BOOM WELDMENT
4	2	65613	WEAR PAD 1/2 x 2 x 3 NSM BEVELED
5	1	0809411U	WHEEL LIFT BOOM HINGE PIN
6	1	729352	PIN -CARRIER W/L EXTEND CYLINDER BASE
7	2	86100E	SNAP RING 1" EXTERNAL
8	4	14710	KEEPER PIN 1.23 x 5.50
9	2	72A33013	LIFT CYLINDER 3.25 x 1.75 x 13.00
10	3		GREASE FITTING 1/4-28
11	4		BOLT, BHCS 3/8-16 UNC x 1
12	5		LOCK WASHER 3/8"
13	2	63595H	WEAR PAD NYLATRON NSM 1/2 x 2 x 4 WITH HOLES
14	2	63595	WEAR PAD NYLATRON NSM 1/2 x 2 x 4
15	1	0808506	CROSSBAR WELDMENT
16	1	8800800	VULCAN WHEEL GRID - LEFT
17	1	8800900	VULCAN WHEEL GRID - RIGHT
18	1	8700190	VULCAN 4000 LB. L-ARM - RIGHT
19	1	8700180	VULCAN 4000 LB. L-ARM - LEFT
20	1	72940	CYLINDER PIN 0.980 x 6-5/8
21	2	86100I	SNAP RING 1" INTERNAL
22	1	0720460	CROSSBAR PIVOT PIN
23	1		BOLT - HEX 3/8-16 x 3/4
24	2	0308132	O-RING 0.125 x 1

Section VI - PARTS

WHEEL LIFT RELEASABLE L-ARMS

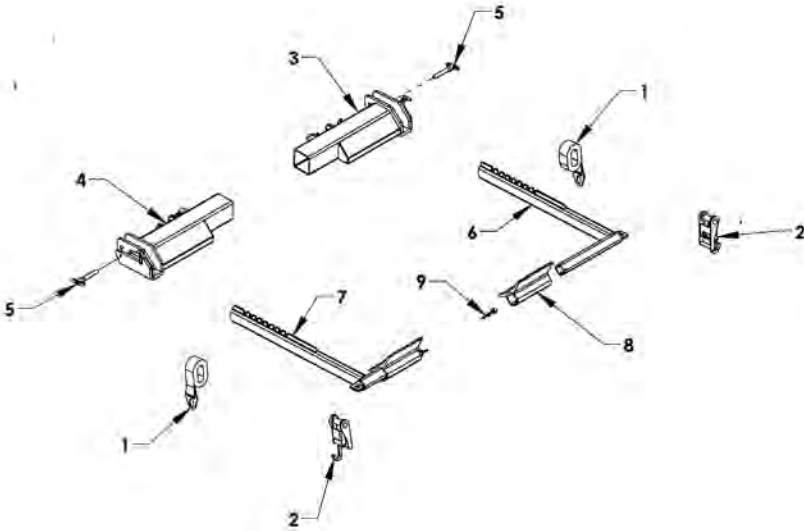

REF. NO.	NO. REQ'D	PART NUMBER	DESCRIPTION
1	2	65285	WHEEL STRAP WITH D-RING - YELLOW
2	2	65280A	WHEEL LIFT RATCHET AND HOOK ASSEMBLY
3	1	65267R	WHEEL GRID - RIGHT
4	1	65267L	WHEEL GRID - LEFT
5	2	84921	T-PIN WITH LANYARD
6	1	65250R	4000 LB. L-ARM RIGHT
7	1	65250L	4000 LB. L-ARM LEFT
8	2	65245	REMOVABLE PAN
9	2	84911	5/16 SAFETY SNAP PIN

Section VI - PARTS
PINTLE ATTACHMENT GROUP

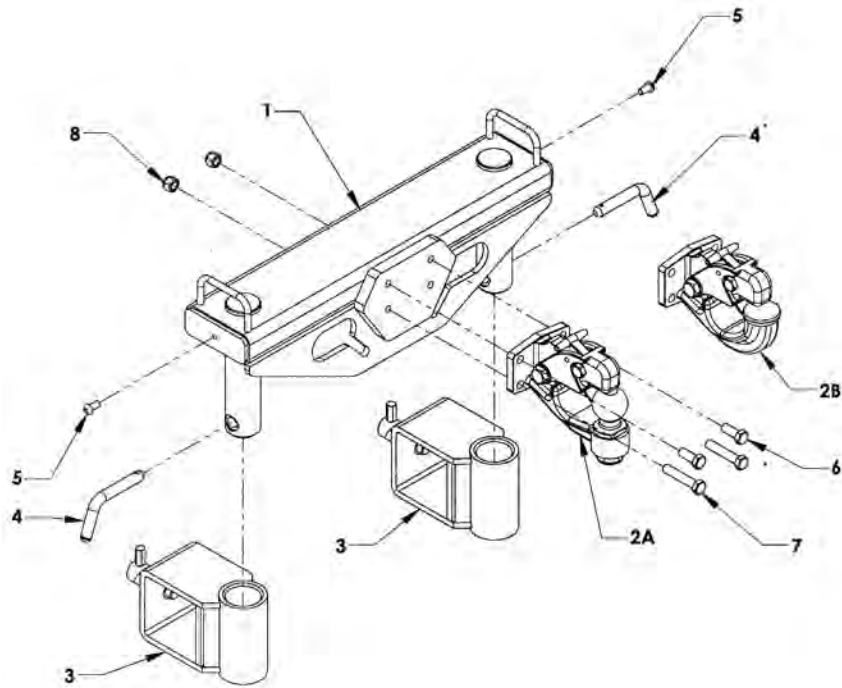

REF	PART #	DESCRIPTION	QPU
	66370G	PINTLE HITCH GROUP	1
1	66370W	PINTLE HITCH WELDMENT	1
2A	A3020	TOW BALL PINTLE HITCH	1
2B	A3020H	PINTLE HOOK	1
3	66280	FORK HOLDER - 4 IN. CROSSBAR	2
	65460	FORK HOLDER - 3-1/2 IN. CROSSBAR	2
4	66378	RETAINING PIN	2
5	812A6	3/8 X 5/8 BUTTONHEAD BOLT	4
	5A220	LANYARD	2
6	81428	BOLT 1/2-13 X 1.25 GRADE 8 SECURE WITH LOCTITE	2
7	81449	BOLT 1/2-13 x 2.5 GRADE 8	2
8	83312	1/2-13 NUT NYLOK	2

Section VI - PARTS
4,000 LB. UNDERLIFT
GEN 2 LCG

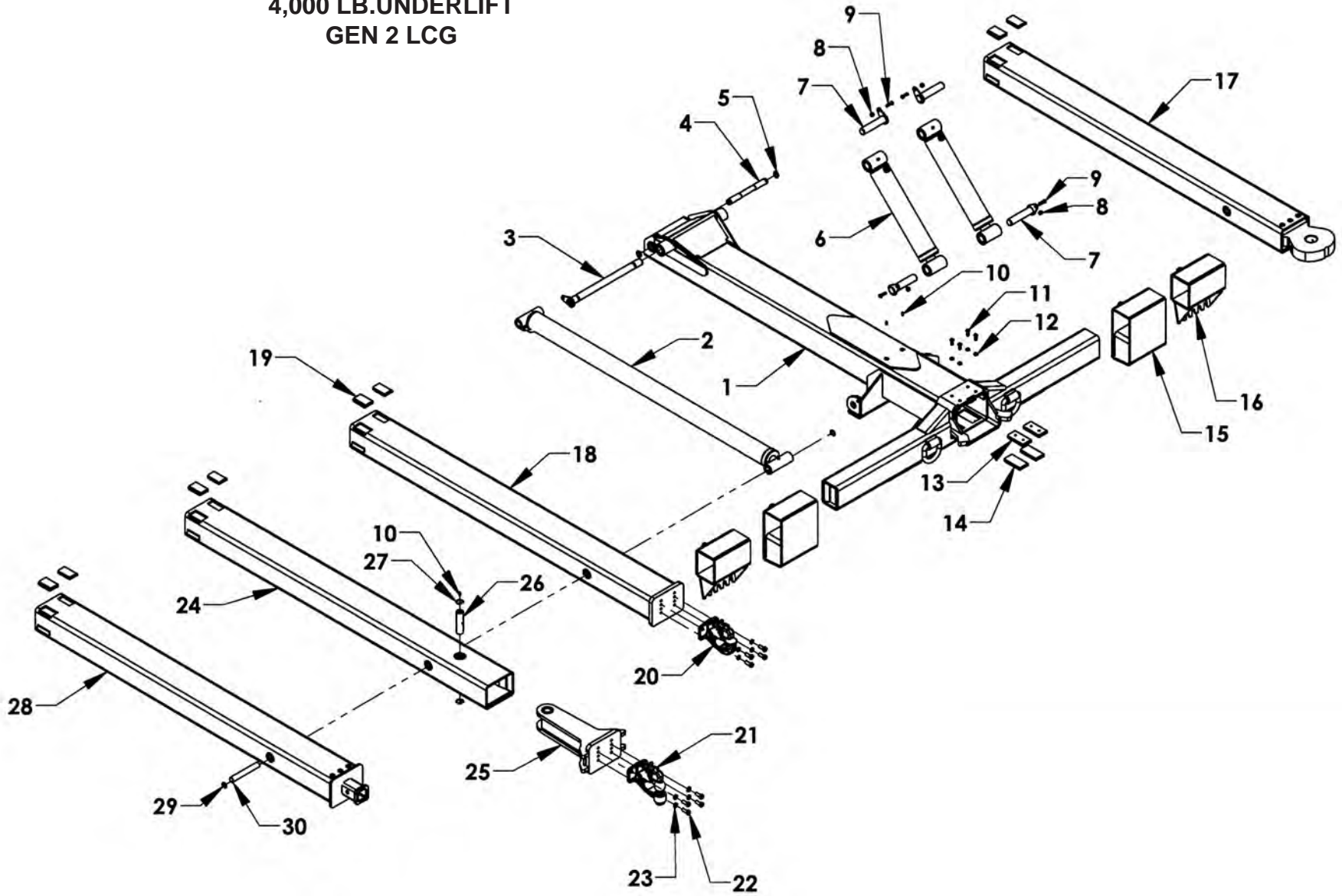

Section VI - PARTS

4,000 LB. UNDERLIFT - GEN 2

REF. NO.	NO. REQ'D	PART NUMBER	DESCRIPTION
1	1	10270408DS	WHEEL LIFT OUTER BOOM TUBE
2	1	72A30054	WL EXTEND CYLINDER 3.0 BORE x 54 STROKE
3	1	0809411U	WHEEL LIFT BOOM HINGE PIN
4	1	729352	PIN - WHEEL LIFT EXTEND CYLINDER BASE
5	2	86100E	SNAP RING 1' EXTERNAL
6	2	72A33013	LIFT CYLINDER 3.25 BORE x 13 STROKE
7	4	14710	KEEPER PIN 1.23 x 5.50
8	4	-	NYLON LOCK NUT 3/8-16 UNC
9	4	-	BOLT, HHCS 3/8-16 UNC x 1-1/4
10	3	7B130	GREASE FITTING 1/4-28
11	4	-	BOLT, BHCS 3/8-16 UNC x 1
12	4	-	LOCK WASHER 3/8
13	2	63595H	WEAR PAD NYLATRON NSM 1/2 x 2 x 4 W/HOLES
14	2	63595	WEAR PAD NYLATRON NSM 1/2 x 2 x 4
15	2	0809898-54	DOCK STABILIZER EXTENSION STAND (OPT)
16	2	0809646-54	DOCK STABILIZER SPADE (OPT)
17	1	102404	4K INNER BOOM TUBE
18	1	10244P	4K INNER PINTLE BOOM TUBE
19	2	65613	WEAR PAD 1/2 x 2 x 3 NSM BEVELED
20	1	A3020H	PINTLE HOOK ATTACHMENT
21	1	A3020	PINTLE BALL ATTACHMENT
22	4	-	BOLT, HEX 1/2-13 UNC x 1-1/4
23	4	-	WASHER 1/2 LOCK
24	1	102404-PP	4K INNER BOOM-PIVOTING PINTLE
25	1	143355	PIVOTING PINTLE HEAD WELDMENT - 4K
26	1	143142PP	PIN - PIVOTING PINTLE HEAD 4K
27	2	86125I	SNAP RING 1-1/4 INTERNAL
28	1	10244R	4K INNER BOOM - REESE RECEIVER
29	2	86100I	SNAP RING 1" INTERNAL
30	1	72940	CYLINDER PIN

Section VI - PARTS

UNDERLIFT CYLINDER FLUID TUBE GROUP

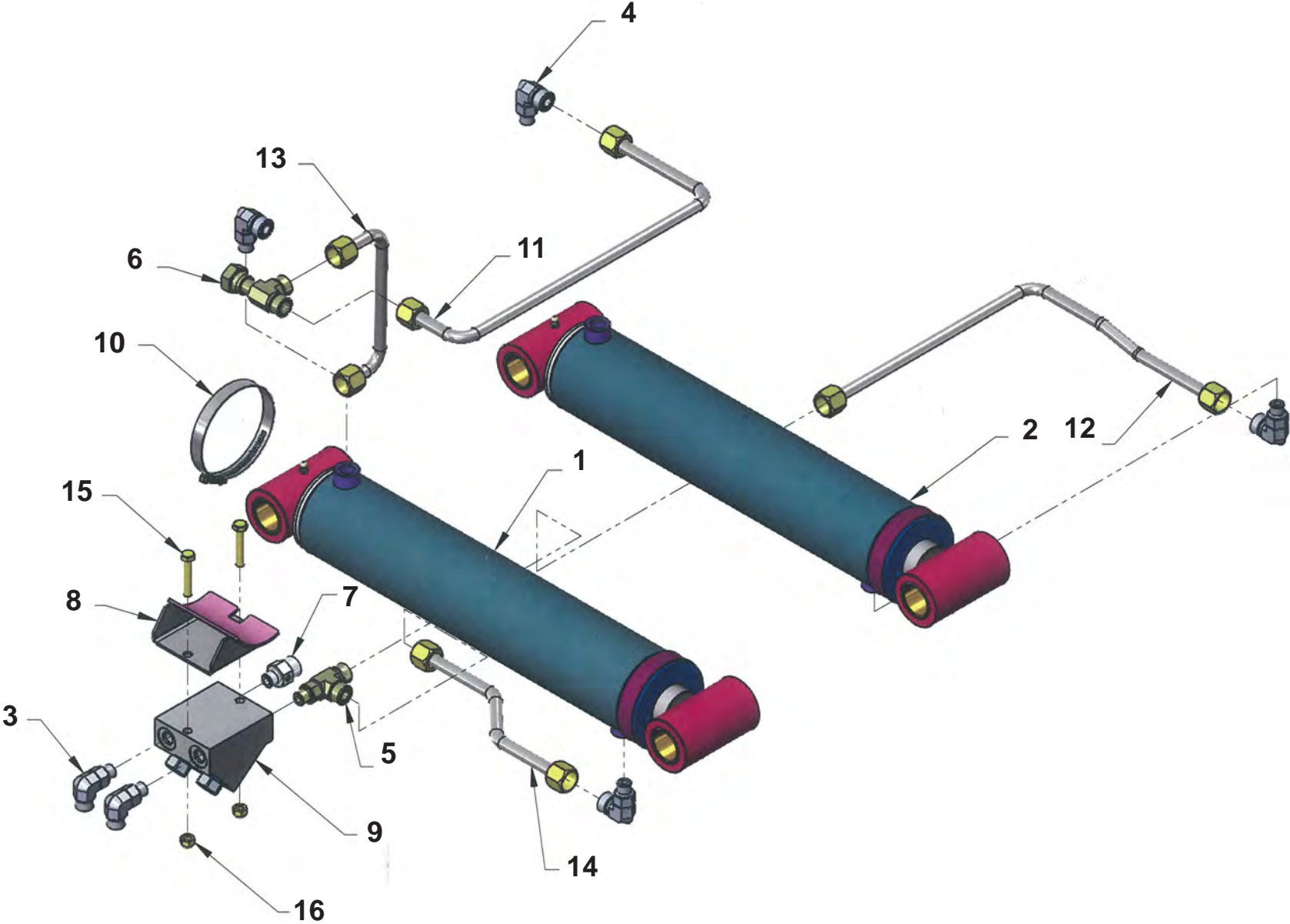

Section VI - PARTS

**UNDERLIFT CYLINDER FLUID
TUBE GROUP**

REF. NO.	NO. REQ'D	PART NUMBER	DESCRIPTION
1	1	72A33013	LIFT CYLINDER 3.25 x 1.75 x 13.00
2	1	72A39013	LIFT CYLINDER 3.25 x 1.75 x 13.00
3	2	ADPTR-FF1868T06065	ADAPTER 90 ORS/ORB 6 x 6
4	4	ADPTR-FF1868T08065	ADAPTER 90 ORS/ORB 8 x 6
5	1	ADPTR-FF1865T08065	ADAPTER TEE ORS/ORB/ORB 8 x 8 x 6
6	1	ADPTR-FF2114T08085	ADAPTER TEE ORS 8 x 8
7	1	ADPTR-FF1852T0806	ADAPTER STRAIGHT ORS/ORB 8 x 6
8	1	0809875-325	UNDERLIFT VALVE MOUNTING BRACKET
9	1	74.45	DUAL COUNTERBALANCE VALVE CBCG-XVN
10	1	85164	HOSE CLAMP 3-3.5 STAINLESS 316
11	1	72H33013L2	UNDERLIFT FLUID TUBE ASSEMBLY - LEFT
12	1	72H33013L1	UNDERLIFT FLUID TUBE ASSEMBLY - LEFT
13	1	72H33013R2	UNDERLIFT FLUID TUBE ASSEMBLY - RIGHT
14	1	72H33013R1	UNDERLIFT FLUID TUBE ASSEMBLY - RIGHT
15	2	BOLT-HX-0312X1750	5/16 x 1-3/4 HEX BOLT
16	2	7A528W	NYLON LOCK NUT 5/16-18 UNC

Section VI - PARTS

PIVOT L-ARM RECEIVER GROUP

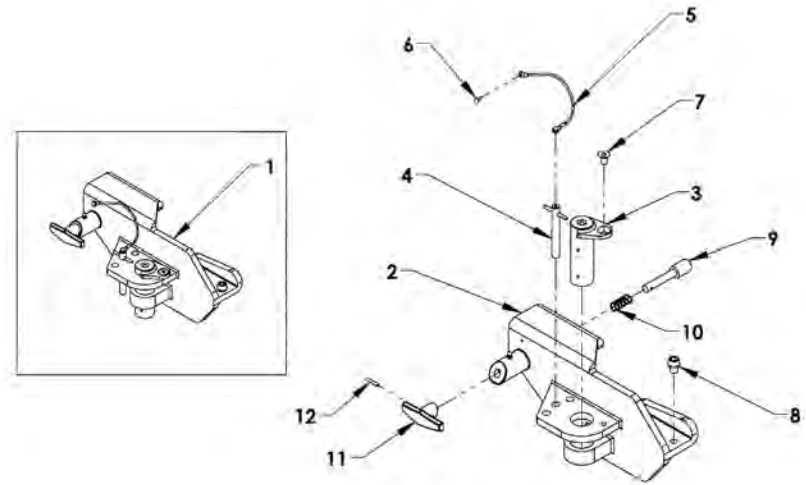

REF. NO.	NO. REQ'D	PART NUMBER	DESCRIPTION
1	1	659820L	PIVOT L-ARM RECEIVER GROUP-LEFT
	1	659820R	PIVOT L-ARM RECEIVER GROUP-RIGHT (SHOWN)
2	1	659821L	PIVOT L-ARM RECEIVER CASTING - LEFT
	1	659821R	PIVOT L-ARM RECEIVER CASTING-RHT (SHOWN)
3	1	659822	L-ARM RECEIVER CASTING PIVOT PIN
4	1	659826	PIVOT LOCK PIN
5	1	659827	LANYARD
6	1	85016	RIVET
7	1	81225	FLAT HEAD SOCKET CAP SCREW 3/8-16 UNC x 1/2
8	1	81226	TAPERED SOCKET CAP SCREW 1/2-13 UNC x 1/2
9	1	659824	7/8 CAM PIN
10	1	89100	CAM PIN SPRING
11	1	659825	T-HANDLE
12	1	84675	ROLL PIN 3/16 x 1

Section VI - PARTS

4,000 LB.WHEEL LIFT
3-WAY PIVOT GEN 2 LCG

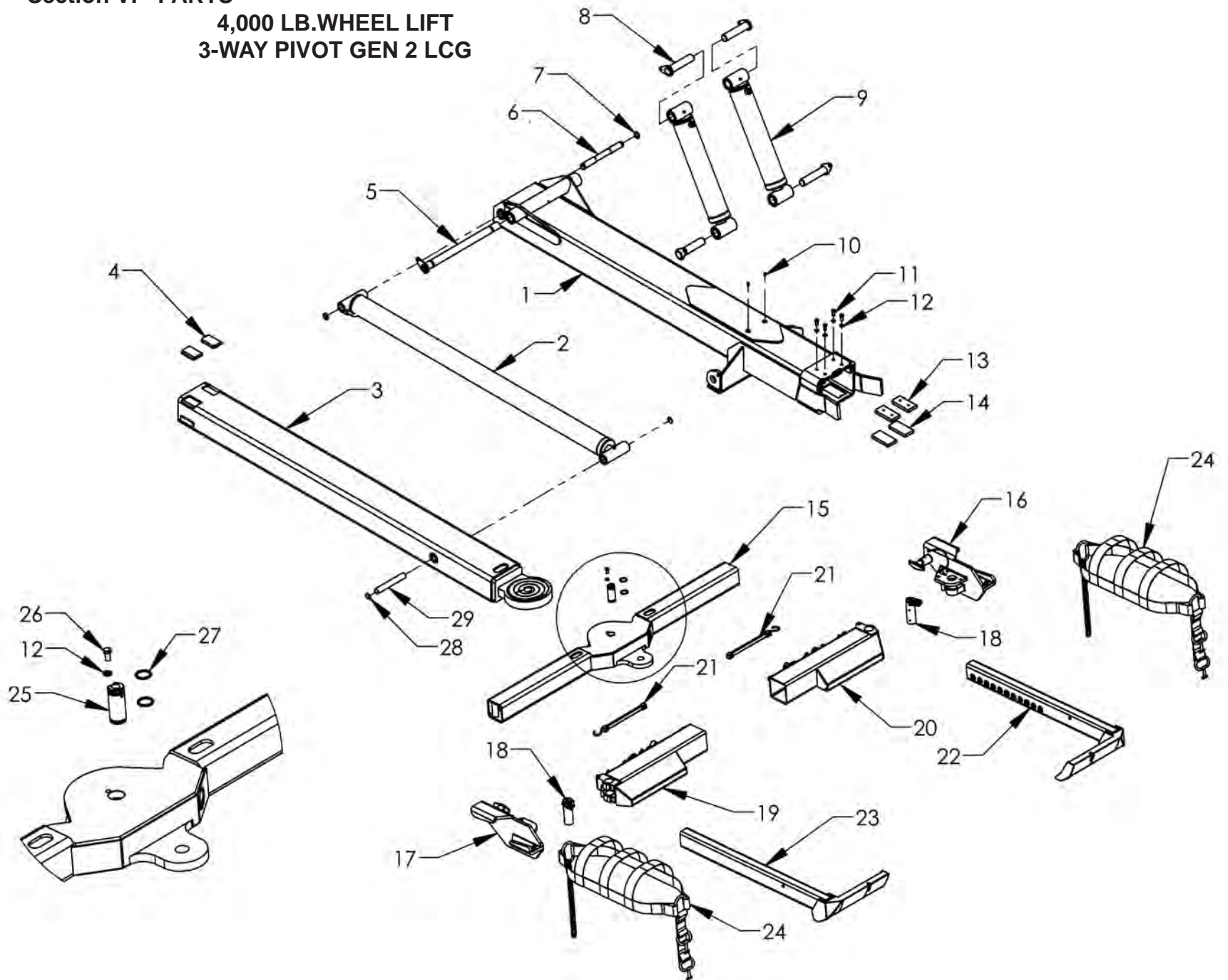

Section VI - PARTS

**4,000 LB. WHEEL LIFT
3-WAY PIVOT GEN 2**

REF NO.	NO REQ'D	PART NUMBER	DESCRIPTION
1	1	0809791	WHEEL LIFT OUTER BOOM TUBE - 4K
2	1	72A30054	WHEEL LIFT EXTEND CYLINDER 3.0 x 54
3	1	0809802	4K INNER BOOM WELDMENT
4	2	65613	WEAR PAD 1/2 x 2 x 3 NSM BEVELED
5	1	0809411U	WHEEL LIFT BOOM HINGE PIN
6	1	729352	PIN -CARRIER W/L EXTEND CYLINDER BASE
7	2	86100E	SNAP RING 1" EXTERNAL
8	4	14710	KEEPER PIN 1.23 x 5.50
9	2	72A33013	LIFT CYLINDER 3.25 x 1.75 x 13.00
10	3		GREASE FITTING 1/4-28
11	4		BOLT, BHCS 3/8-16 UNC x 1
12	5		LOCK WASHER 3/8"
13	2	63595H	WEAR PAD NYLATRON NSM 1/2 x 2 x 4 WITH HOLES
14	2	63595	WEAR PAD NYLATRON NSM 1/2 x 2 x 4
15	1	0808506	CROSSBAR WELDMENT
16	1	659821R	PIVOT L-ARM RECEIVER - RIGHT
17	1	659821L	PIVOT L-ARM RECEIVER - LEFT
18	2	659822	L-ARM PIVOT PIN
19	1	0809290L	PIVOT WHEEL GRID - LEFT
20	1	0809290R	PIVOT WHEEL GRID - RIGHT
21	2	AA009G	RUBBER TENSION STRAP WITH S-HOOK
22	1	0803649	3-WAY PIVOT L-ARM - RIGHT
23	1	0803648	3-WAY PIVOT L-ARM - LEFT
24	2	65286	BASKET STRAP - CAR
	2	65287	BASKET STRAP - TRUCK
25	1	0720460	CROSSBAR PIVOT PIN
26	1		BOLT - HEX 3/8-16 x 3/4
27	2	0801332	O-RING 0.125 x 1
28	2	86100I	SNAP RING 1" INTERNAL
29	1	72940	CYLINDER PIN 0.980 x 6-5/8

Section VI - PARTS

DOCK STABILIZER

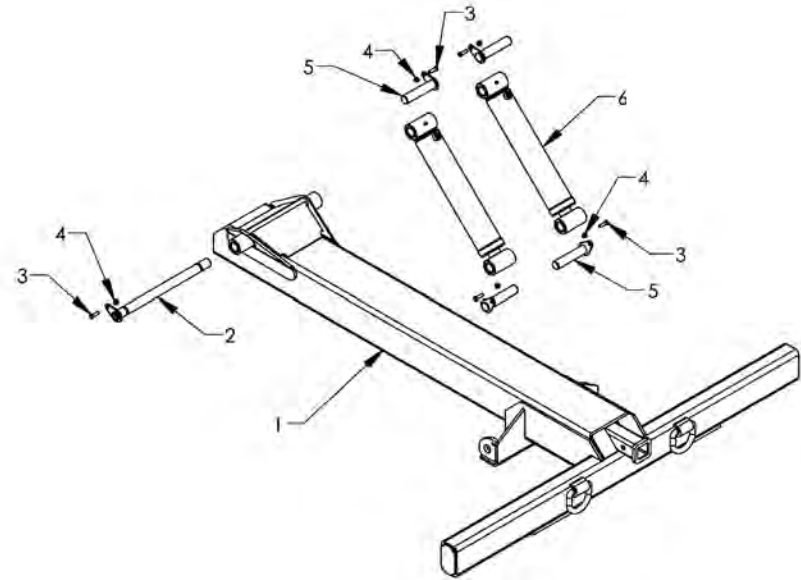

REF NO.	NO REQ'D	PART NUMBER	DESCRIPTION
1	1	0810010-12	DOCK STABILIZER WELDMENT
2	1	0809411U	WHEEL LIFT BOOM HINGE PIN
3	5		BOLT HHCS, 3/8-16 UNC x 1-1/4
4	5		NYLON LOCK NUT, 3/8-16 UNC
5	4	14710	KEEPER PIN 1.23 x 5.50
6	2	72A33013	LIFT CYLINDER 3/25 x 1.75 x 13.0

Section VI- PARTS
AUTOGRIP WHEEL LIFT

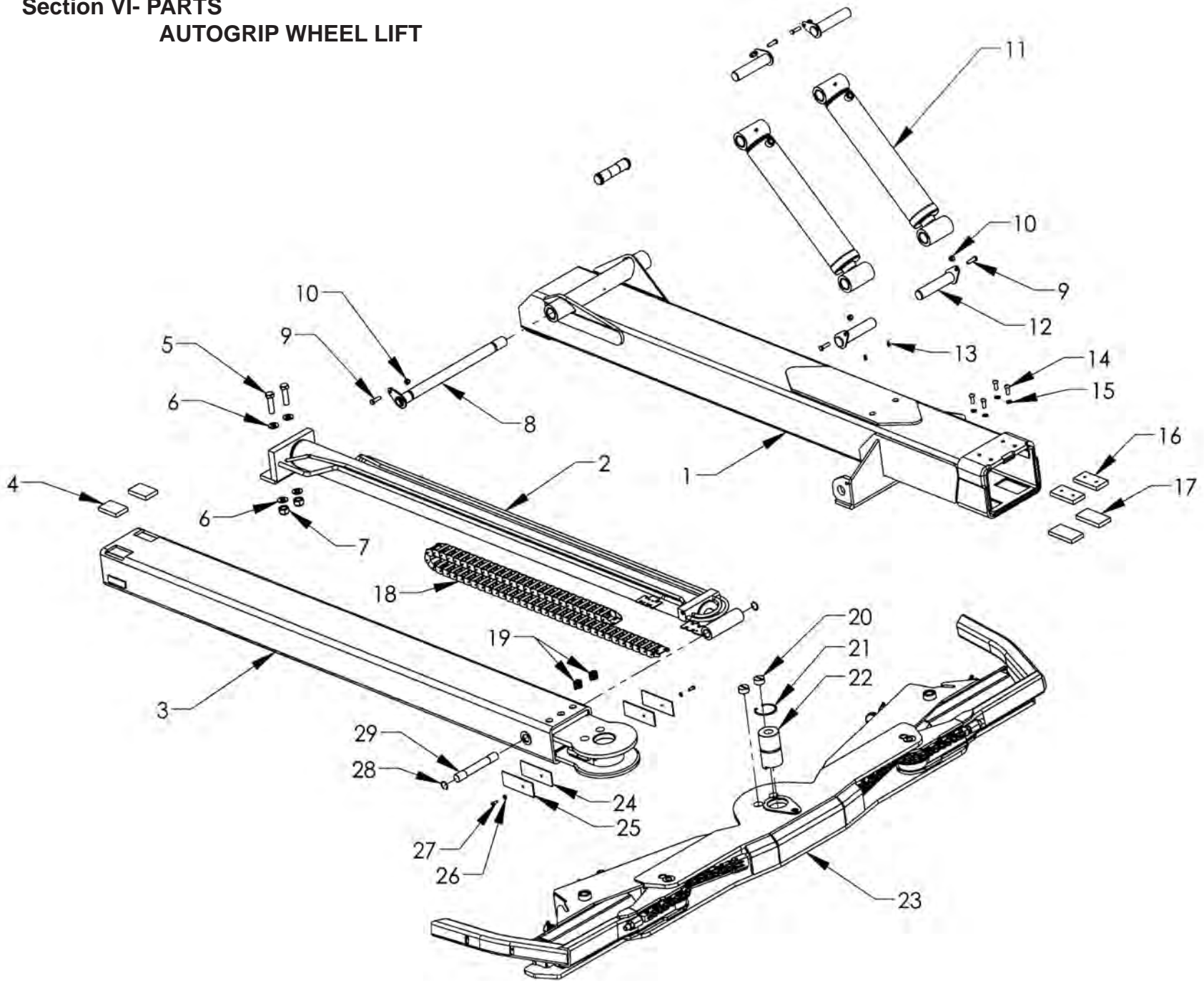

Section VI- PARTS
AUTOGRIP WHEEL LIFT

REF NO.	NO REQ'D	PART NUMBER	DESCRIPTION
1	1	10270410	AUTOGRIP OUTER BOOM TUBE - GEN2 LCG 4K
2	1	72136	AUTOGRIP EXTEND CYLINDER - CARRIER
3	1	102522	AUTOGRIP INNER TUBE GEN2
4	2	65612	WEAR PAD 1/2 x 2 x 3 NSM BEVELED
5	2		BOLT HHCS 5/8-11 UNC x 2-1/4
6	4		FLAT WASHER 5/8
7	2		NYLON LOCK NUT 5/8-11 UNC
8	1	0809411U	WHEEL LIFT BOOM HINGE PIN
9	5		BOLT, HHCS 3/8-16 UNC x 1-1/4
10	5		NYLON LOCK NUT 3/8-16 UNC
11	2	72A33013	LIFT CYLINDER 3.25 x 1.75 x 13.00
12	4	14710	KEEPER PIN 1.23 x 5.50
13	2		GREASE FITTING 1/4-28 UNF
14	4		BOLT, BHCS 3/8-16 UNC x 1
15	4		LOCK WASHER 3/8"
16	2	63595H	WEAR PAD NYLATRON NSM 1/2 x 2 x 4 WITH HOLES
17	2	63595	WEAR PAD NYLATRON NSM 1/2 x 2 x 4
18	1	69757	AUTOGRIP HOSE TRACK 58 LINKS
19	2	69320	AUTOGRIP DETENT SPRING GEN2
20	2	643272	AUTOGRIP DETENT SCREW GEN2
21	1	86250I	SNAP RING 2-1/2" INTERNAL
22	1	644402	AUTOGRIP CROSSBAR PIVOT PIN GEN2
23	1	644002CG	AUTOGRIP CROSSBAR GEN2
24	2	64304R	RUBBER GASKET FOR 64304C
25	2	64304C	HOSE CLAMP FOR SIDE OF AUTOGRIP II YOKE
26	2		LOCK WASHER 1/4"
27	2		BOLT, BUTTON HEAD 1/4-20 x 3/4
28	2	86100I	SNAP RING 1" INTERNAL
29	1	72940	CYLINDER PIN 0.980 x 6-5/8

Section VI - PARTS
AUTOGRIP II COMPONENTS

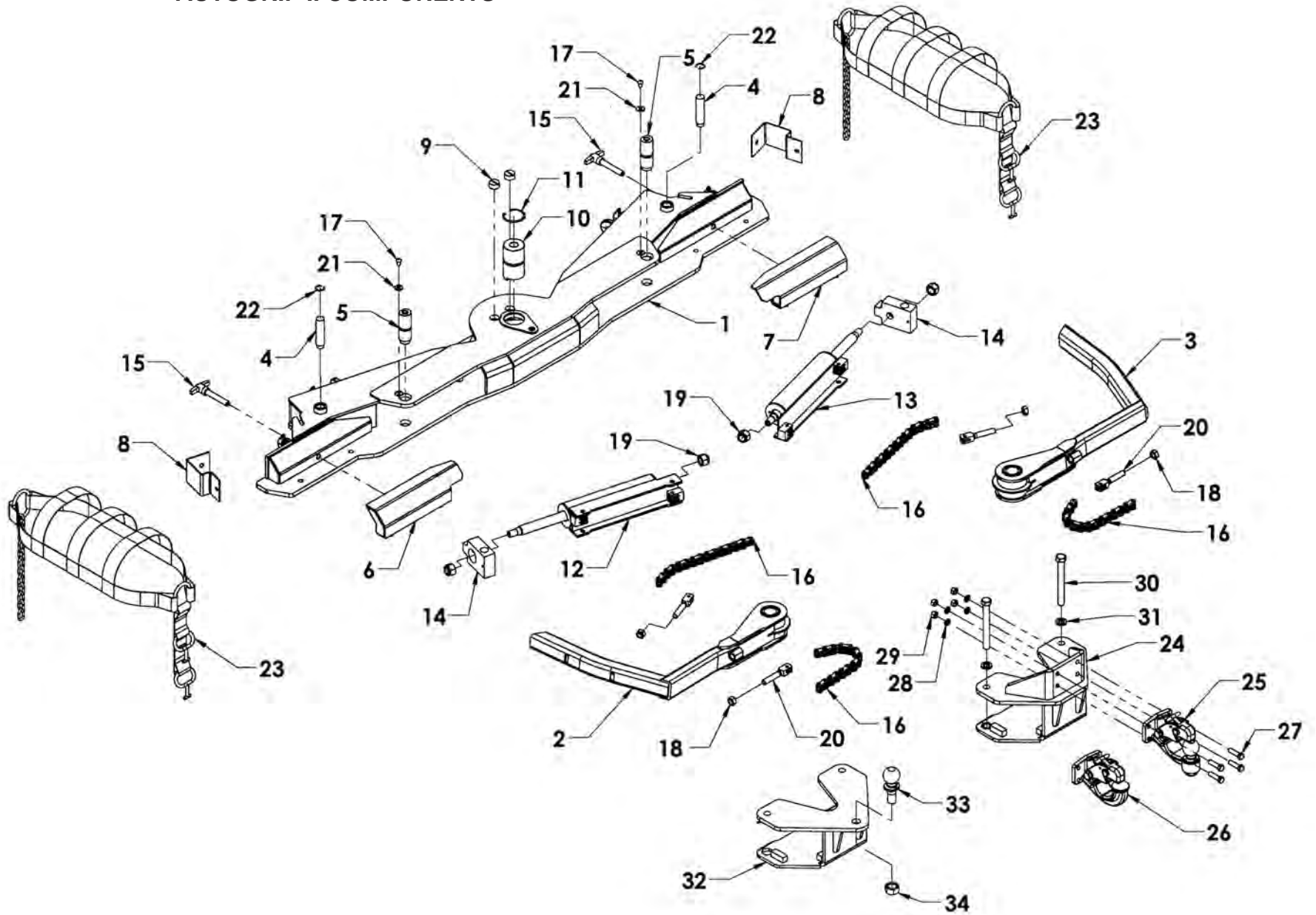

Section VI - PARTS

AUTOGRIP II COMPONENTS

REF NO.	NO REQ'D	PART NUMBER	DESCRIPTION
1	1	644002	CROSSBAR WELDMENT
2	1	644352	WHEEL RETAINER - LEFT
3	1	644352	WHEEL RETAINER - RIGHT
4	2	644432	WHEEL RETAINER CYLINDER PIN
5	2	644452	ARM PIVOT PIN
6	1	697402L	WHEEL SPACER - LEFT
7	1	697402R	WHEEL SPACER - RIGHT
8	2	644292	HOSE GUARD
9	2	64327	SCREW-PLUG CROSSBAR DETENT
10	1	644402	CROSSBAR PIN
11	1	862501	SNAP RING 2.500 INCH INTERNAL
12	2	720152L	WHEEL RETAINER CYLINDER - LEFT
13	2	720152R	WHEEL RETAINER CYLINDER - RIGHT
14	2	727162	L-ARM CYLINDER END BLOCK
15	2	84291	T-PIN 5/8 x 3
16	4	87440	AUTOGRIP ARM CHAIN
	4		5/16 x 1-1/4 SHOULDER SHCS 1/4-20 UNC
	4		1/4-20 UNC NYLON LOCK NUT
17	2		3/8 ALLEN BOLT
18	4		5/8 NYLON LOCK NUT
19	2	644432	3/4 NYLON LOCK NUT
20	4	64441	CHAIN CLEVIS
	4		5/16 x 1 SHOULDER SHCS 1/4-20 UNC
	4		1/4-20 UNC NYLON LOCK NUT
21	2		5/16 FLAT WASHER
22	2	861001	SNAP-RING 1.000 INCH INTERNAL
23	2	65286	BASKET TIRE STRAP - AUTO
	2	66287	BASKET TIRE STRAP - TRUCK
24	1	694520	AUTOGRIP PINTLE ADAPTOR (OPTIONAL)
25	1	A3020	PINTLE BALL ATTACHMENT (OPTIONAL)
26	1	A3020H	PINTLE HOOK ATTACHMENT (OPTIONAL)
27	4		BOLT, HHCS 1/2-13 UNC x 1-1/34
28	4		LOCK WASHER, 1/2
29	4		HEX NUT 1/2-13 UNC
30	2		BOLT, HHCS 3/14-10 UNC x 6-1/2
31	2		LOCK WASHER 3/4
32	1	694510	AUTOGRIP TOWBALL ADAPTOR (OPTIONAL)
33	1		TOWBALL
34	1	83711	NUT - 1" NF RAMCO LOCK

Section VI - PARTS INBOARD TILT CYLINDERS

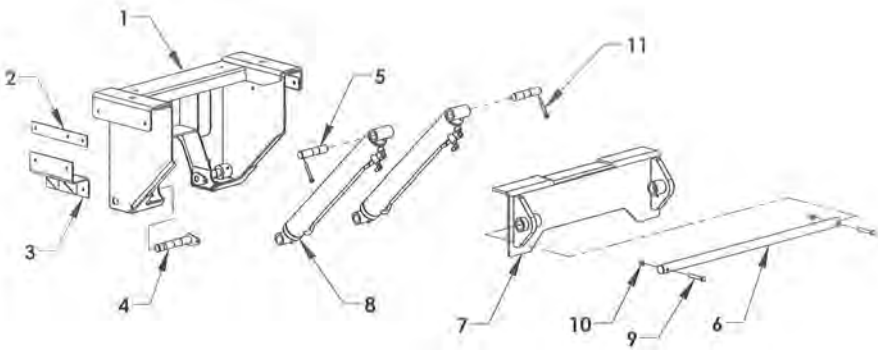

REF	PART #	DESCRIPTION	QPU
1	1A8002	INTERNAL SADDLE	1
2	1A821S	SADDLE SHIM	2
3	1A825	FRAME MOUNTING BRACKET	2
4	1A828A	INBOARD SADDLE TILT PIN	2
5	13068	PIN - TILT CYLINDER BASE	2
6	0750952	HINGE PIN - 1-1/2 x 41-3/8	1
7	0809533	HINGE ANGLE	1
8	721092	CYLINDER - CARRIER TILT	2
9	81451	BOLT 1/2-20 UNF x 3 GRADE 5	2
10	83324	NYLON LOCK NUT 1/2-20 UNF	2
11	84680	PIN EYE	2

Section VI - PARTS

INBOARD OIL RESERVOIR GROUP

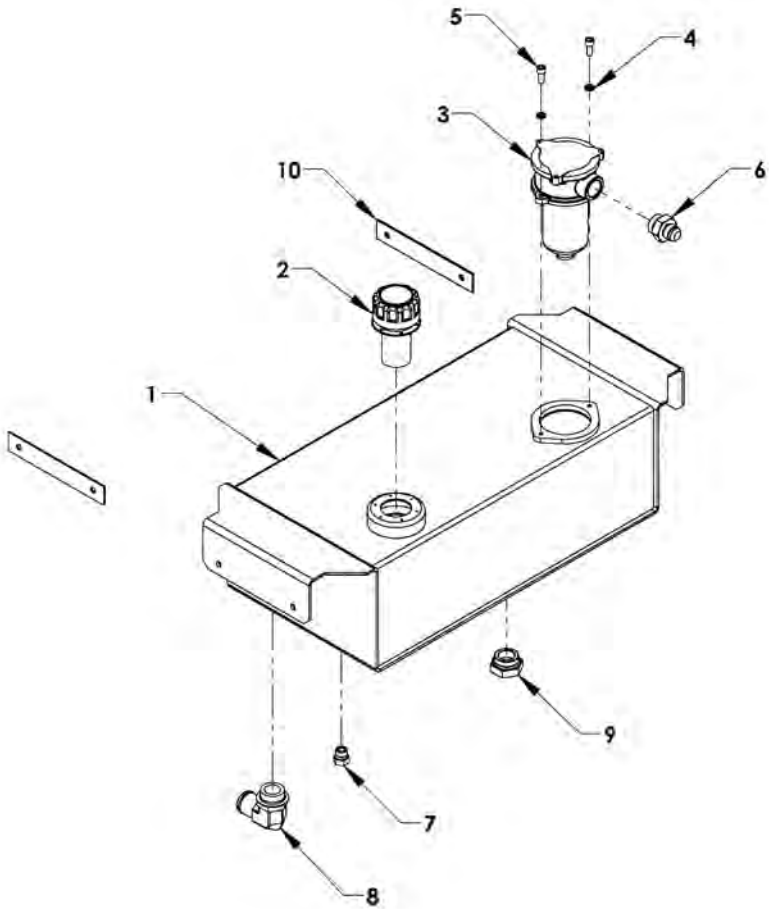

REF. NO.	NO. REQ'D	PART NUMBER	DESCRIPTION
1	1	763100	INBOARD OIL RESERVOIR WELDMENT
2	1	76213	FILLER BREATHER CAP
3	1	76270	FILTER ASSEMBLY
	1	76271	REPLACEMENT FILTER ELEMENT
4	2	82220	LOCK WASHER 3/8 ZP
5	2	812A8	BHCS 3/8-16 UNC x 7/8 SS
6	1	ADPTR202702-16 x 12	ADAPTOR 202702-16 x 12
7	1	ADPTR900598-8	ADAPTOR 900598-8 (DRAIN PLUG)
8	1	77C92	20 x 24 SUCTION HOSE FITTING 90°
9	1	ADPTR900598-20	ADAPTOR 90059-20 (DRAIN PLUG)
10	2	763106	FRAME WIDTH SHIM

Section VI - PARTS

12 GAL. OUTBOARD OIL TANK GROUP

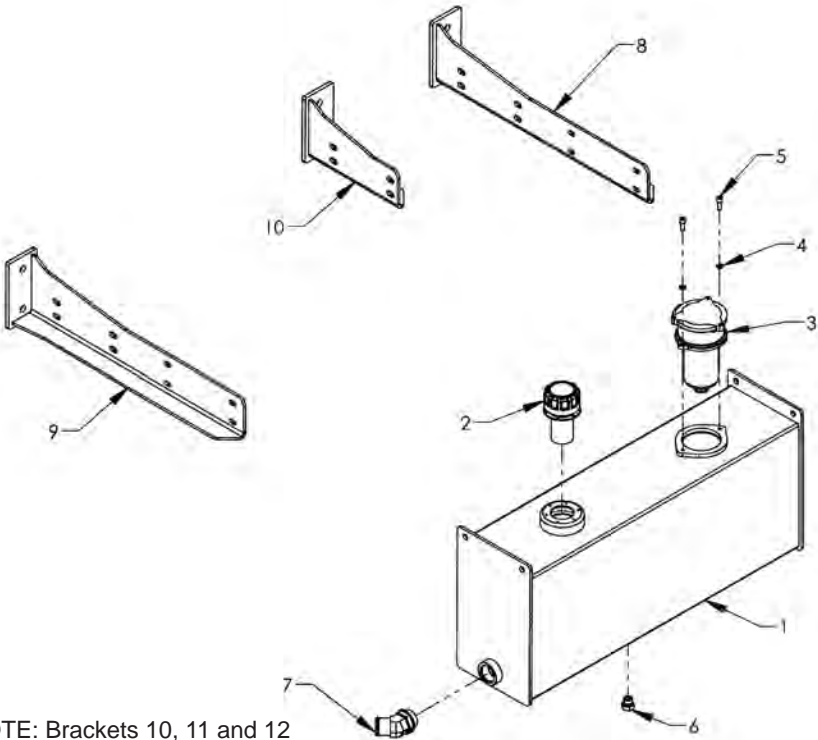

NOTE: Brackets 10, 11 and 12 are shown offset down for LCG carriers 12 and 16. They can be reversed to be offset up for conventional carriers.

REF	PART #	DESCRIPTION	QPU
1	762110	12 GAL. OUTBOARD OIL TANK WELDMENT	1
2	76213G	FILLER BREATHER CAP ASSEMBLY	1
3	76270	IN-TANK FILTER ASSEMBLY #16 SAE PORT	1
4	LWSHR-0312	LOCK WASHER 5/16 ZINC PLATE	2
5	BOLT-CS-0313X0875	BHCS 5/16-18 UNC x 7/8 SS	2
6	0403113	#8 O-RING PLUG-ADAPTOR 900898-8	1
7	ADPTR2061-20x24H	ADAPTOR 2061-20 x 24H (24 GPM)	1
8	37855L	TOOL BOX AND OIL TANK MTG. BRACKET - L	1
9	37855R	TOOL BOX AND OIL TANK MTG. BRACKET - R	1
10	37858L	OIL TANK MOUNTING BRACKET - LEFT	1

Section VI - PARTS

2 AIR VALVE CONTROL STATION

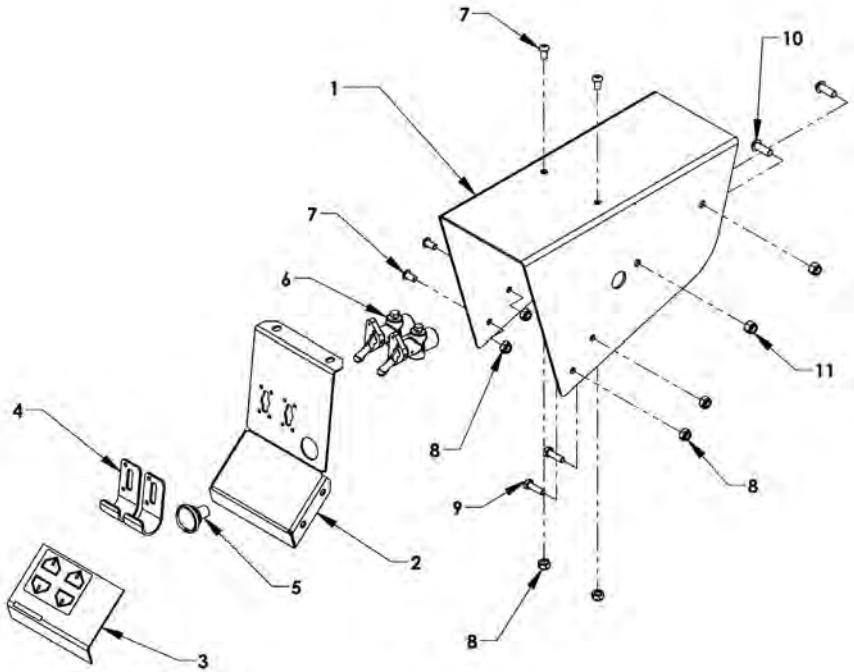

REF. NO.	NO. REQ'D	PART NUMBER	DESCRIPTION
1	1	18148	2-TOGGLE AIR VALVE CONTROL HOOD
2	1	18149L	2-TOGGLE AIR VALVE CONTROL PANEL - LEFT
	1	18148R	2-TOGGLE AIR VALVE CONTROL PANEL - RIGHT
3	1	18221L	2-TOGGLE AIR VALVE CONTROL PLACARD - LEFT
	1	18221R	2-TOGGLE AIR VALVE CONTROL PLACARD - RIGHT
4	2	18145	TOGGLE AIR VALVE GUARD
5	1	97300	CONTROL LIGHT
6	2	71716	TOGGLE AIR VALVE
7	4	-	BOLT BHCS 5/16-18 UNC x 5/8
8	6	-	NYLON LOCK NUT 5./16 UNC
9	2	-	BOLT HHCS 5/16-18 UNC x 1
10	2	-	BOLT BHCS 3/8-16 UNC x 1
11	2	-	NYLON LOCK NUT 3/8-16 UNC

Section VI - PARTS
6-SPOOL CONTROL STATION

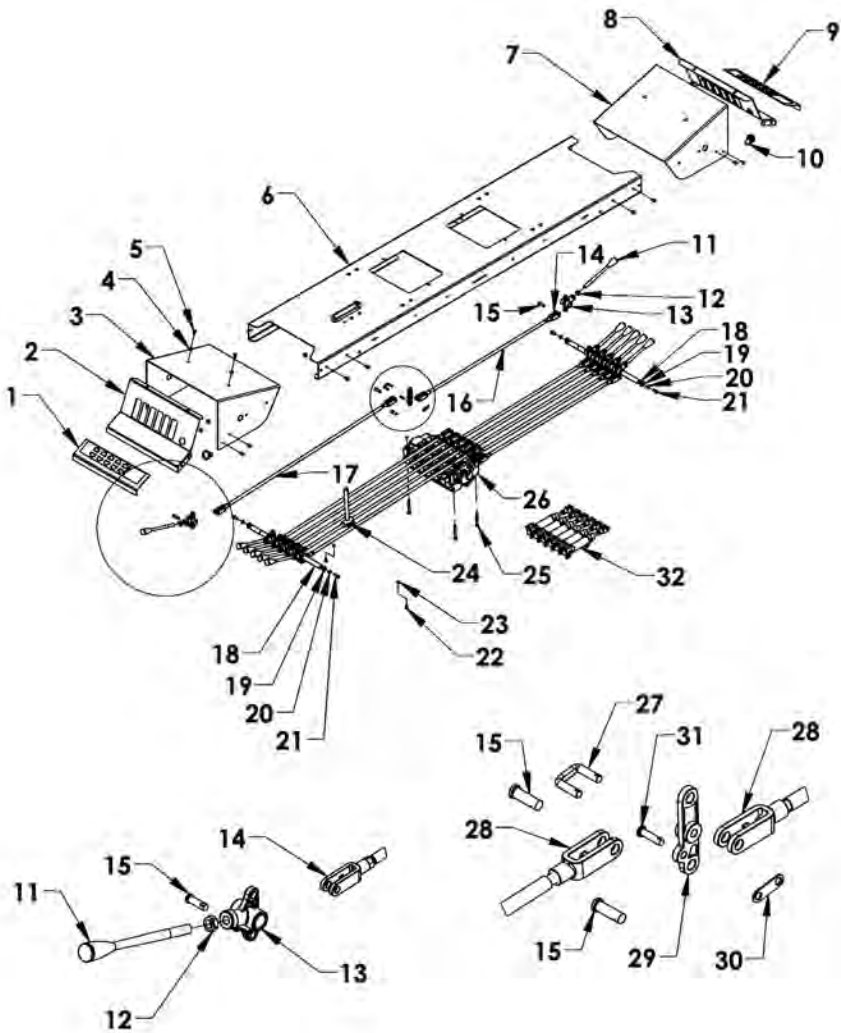

Section VI - PARTS

6-SPOOL CONTROL STATION

REF. NO.	NO. REQ'D	PART NUMBER	DESCRIPTION
1	1	18212L/18214L	5 SPOOL/6 SPOOL CONTROL PLACARD-LEFT
2	1	18126L	CONTROL PANEL - LEFT
3	1	181273L	CONTROL HOOD - LEFT
4	23		NYLON LOCK NUT 5/16-18 UNC
5	16		BOLT, BUTTON HEAD 5/16-18 UNC x 5/8
6	1	181286W	CONTROL BOX ARM WELDMENT - 79.5 IN.
7	1	181273R	CONTROL HOOD - RIGHT
8		18126R	CONTROL PANEL - RIGHT
9	1	18212R/18214R	5 SPOOL/6 SPOOL CONTROL PLACARD - RIGHT
10	1	0320031	CONTROL LIGHT - 2 WIRE
11	2	0320048-GR	GREEN CONTROL HANDLE
	4	0320048-BL	BLUE CONTROL HANDLE
	2	0320048-RD	RED CONTROL HANDLE
	4	0320048-GY	GREY CONTROL HANDLE
12	12		JAM NUT 1/2-13 UNC ZINC PLATE
13	12	7A1155	CONTROL HANDLE PIVOT BASE
14	12	84530	CLEVIS - RIGHT HAND THREAD
15	24	84620	CLEVIS PIN, 3/8 x 1-1/8
16	6	7A528W	CONTROL ROD 28-1/2
17	6	7A538W	CONTROL ROD 37-3/4
18	2	7A5753-17	CONTROL HANDLE CROSS ROD 3/4 x 17
19	4	86075E	SNAP RING 3/4 EXTERNAL
20	4		LOCK WASHER 3/8
21	4		BOLT, BUTTON HEAD 3/8-16 UNC x 3/4
22	4		BOLT, HHCS 1/4-20 UNC x 3/4
23	4		NYLON LOCK NUT 1/4-20 UNC
24	1	0809904	ANTI-TILT CONTROL ROD WELDMENT
25	3		BOLT, HHCS 5/16 -18 UNC x 2-3/4
26	1	74116	VALVE BODY GRESN 6 SPOOL
27	6	7A010LINK	CLEVIS LINK
28	12	84540	CLEVIS - LEFT HAND THREAD
29	6	7A121	BELL CRANK
30	6	7A010LINKPLATE	CLEVIS LINK PLATE
31	6	84610	CLEVIS PIN, 1/4 x 15/16
32	6	PC32850	AIR CYLINDER - 2 IN. STROKE

Section VI - PARTS
9-SPOOL CONTROL STATION

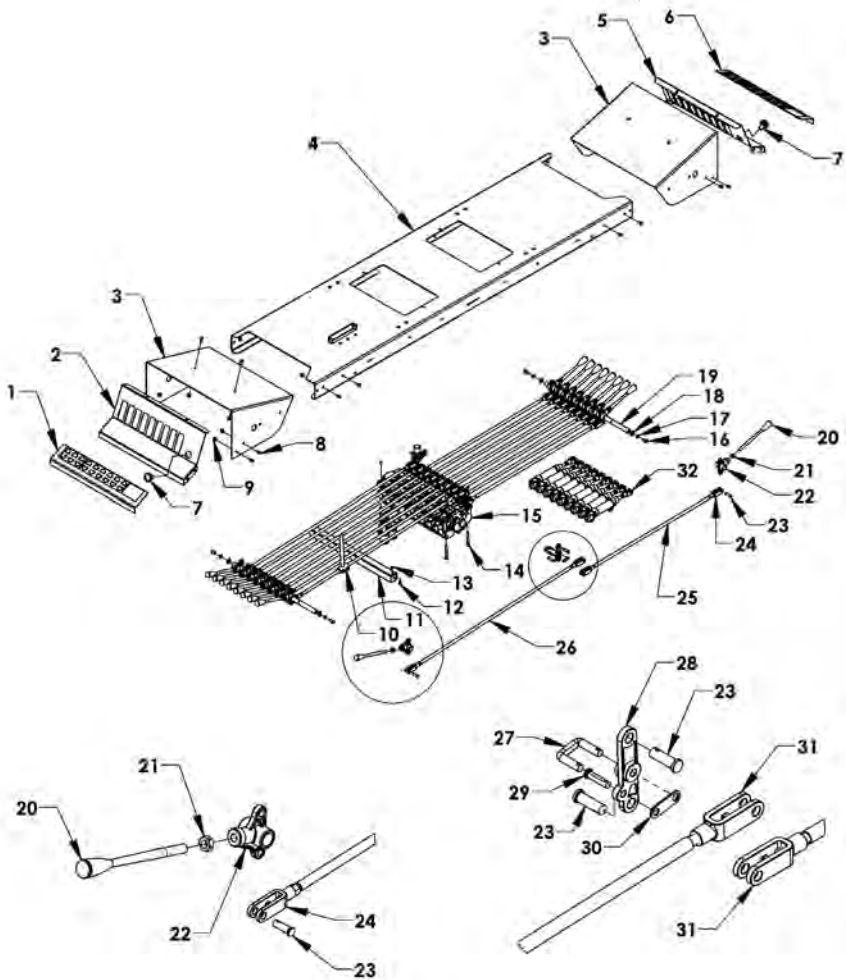

Section VI - PARTS

9-SPOOL CONTROL STATION

REF. NO.	NO. REQ'D	PART NUMBER	DESCRIPTION
1	1	18219L	CONTROL PLACARD - LEFT
2	1	18142L	CONTROL PANEL - LEFT
3	2	18141	CONTROL HOOD
4	1	181289W	CONTROL BOX ARM WELDMENT - 79.5 IN.
5	1	18142R	CONTROL PANEL - RIGHT
6	1	18219R	CONTROL PLACARD - RIGHT
7	2	0320031	CONTROL LIGHT 2 WIRE
8	20		BOLT, BUTTON HEAD 5/16-18 UNC x 5/8
9	23		NYLON LOCK NUT 5/16-18 UNC
10	1	0809904	ANTI-TILT CONTROL ROD WELDMENT
11	1	18336	CONTROL STATION WIRE TUBE
12	4		BOLT, HHCS 1/4-20 UNC x 3/4
13	4		NYLON LOCK NUT 1/4-20 UNC
14	3		BOLT, HHCS 5/16 -18 UNC x 2-3/4
15	1	74119	VALVE BODY GRESEN 9 SPOOL
16	4		BOLT, BUTTON HEAD 3/8-16 UNC x 3/4
17	4		LOCK WASHER - 3/8
18	4	86075E	SNAP RING 3/4 EXTERNAL
19	2	7A5753-20	CROSS ROD 3/4 X 20-3/4
20	6	0320048-BL	BLUE CONTROL HANDLE
	6	0320048-RD	RED CONTROL HANDLE
	2	0320048-GR	GREEN CONTROL HANDLE
	4	0320048-GY	GRAY CONTROL HANDLE
21	18		JAM NUT 1/2-13 UNC ZINC PLATED
22	18	7A1155	CONTROL HANDLE PIVOT BASE
23	36	84620	CLEVIS PIN - 3/8 x 1-1/8
24	18	84530	CLEVIS - RIGHT HAND THREAD
25	9	7A528W	CONTROL ROD 28-1/2
26	9	7A538W	CONTROL ROD 37-3/4
27	9	7A010LINK	CLEVIS LINK
28	9	7A121	BELL CRANK
29	9	84610	CLEVIS PIN, 1/4 x 15/16
30	9	7A010LINKPLATE	CLEVIS LINK PLATE
31	18	84540	CLEVIS - LEFT HAND THREAD
32	9	PC32B50	AIR CYLINDER - 2 IN. STROKE

Section VI - PARTS

RAMSEY 234 HYDRAULIC WINCH

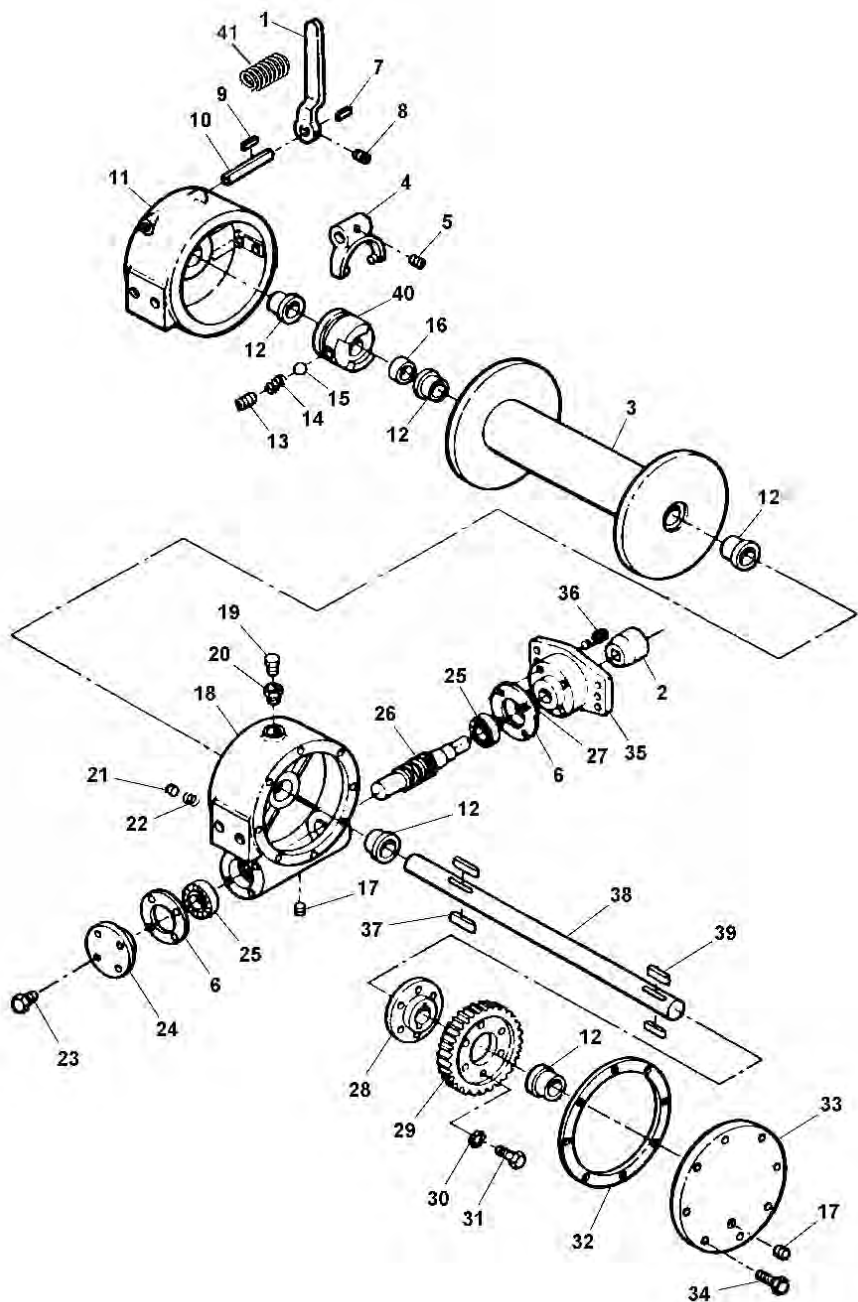

Section VI - PARTS

RAMSEY 234 HYDRAULIC WINCH

REF. NO.	NO. REQ'D	PART NUMBER	DESCRIPTION
1	1	0300261	LEVER
2	1	0300290	COUPLING
3	1	0300381	DRUM
4	1	0300398	YOKE
5	1	0300399	SCREW
6	2	0300447	GASKET
7	1	0300448	KEY
8	1	0300449	SCREW
9	1	0300450	KEY
10	1	0300451	SHAFT
11	1	0300452	CLUTCH HOUSING
12	5	0300453	BUSHING
13	1	0300454	SCREW
14	1	0300455	SPRING
15	1	0300456	BALL
16	1	0300458	SPACER
17	2	0300459	PLUG
18	1	0300460	HOUSING
19	1	0300461	PLUG
20	1	0300462	REDUCER
21	1	0300463	DRAG BRAKE
22	1	0300464	SPRING
23	16	0300465	SCREW
24	1	0300466	CAP
25	2	0300467	BEARING
26	1	0300468	WORM
27	1	0300471	SEAL
28	1	0300472	HUB
29	1	0300473	GEAR
30	6	0300474	WASHER
31	6	0300475	SCREW
32	1	0300476	GASKET
33	1	0600477	COVER
34	4	0300569	SCREW
35	1	0300694	CAP ADAPTER
36	1	0300695	SCREW
37	2	--	KEY
38	1	--	SHAFT
39	2	--	KEY
40	1	--	CLUTCH
41	1	0308608	TORSION SPRING
*	1	0308698	4 TON WORM WINCH ASSEMBLY

* When ordering specify winch serial number.

Section VI - PARTS

WINCH CLUTCH CONTROL

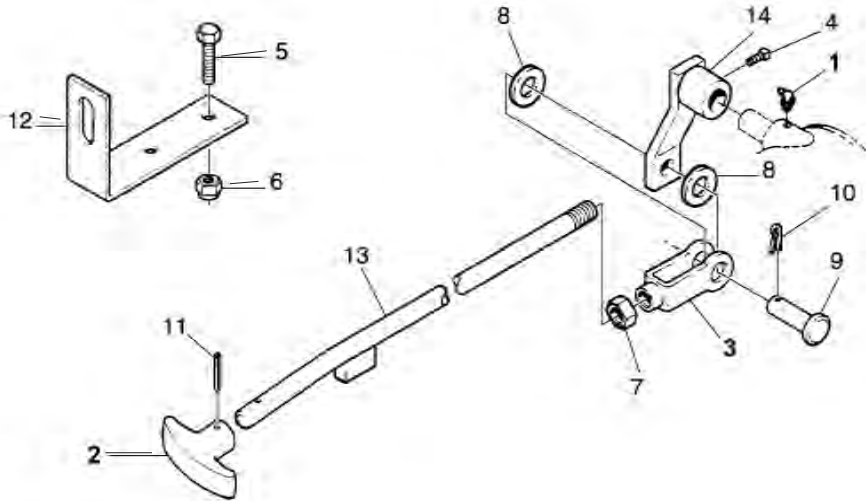

REF. NO.	NO. REQ'D	PART NUMBER	DESCRIPTION
1	1	0301397	GREASE FITTING, 90°
2	1	0301532	"T" HANDLE
3	1	0301588	ADJUSTING YOKE
4	1	0400116	SCREW, 5/16"-18 x 1/2" SQ HD SET
5	2	0400126	SCREW, 3/8"-16 x 1" HEX HD CAP
6	2	0400392	NUT, 3/8"-16 NYLOK
7	1	0400410	NUT, 1/2"-13 JAM
8	4	0400492	WASHER, 1/2" FLAT
9	1	0400537	PIN, 1/2" x 1-1/2" CLEVIS
10	1	0400546	PIN, 1/8" x 1-1/4" COTTER
11	2	0400560	PIN, 5/32" x 1" ROLL
12	1	0710918	MOUNTING ANGLE
13	1	0805170	CONTROL ROD
14	1	0805151	BELL CRANK

Section VI - PARTS

CABLE TENSIONER ASSEMBLY (STANDARD 4-TON WINCH)

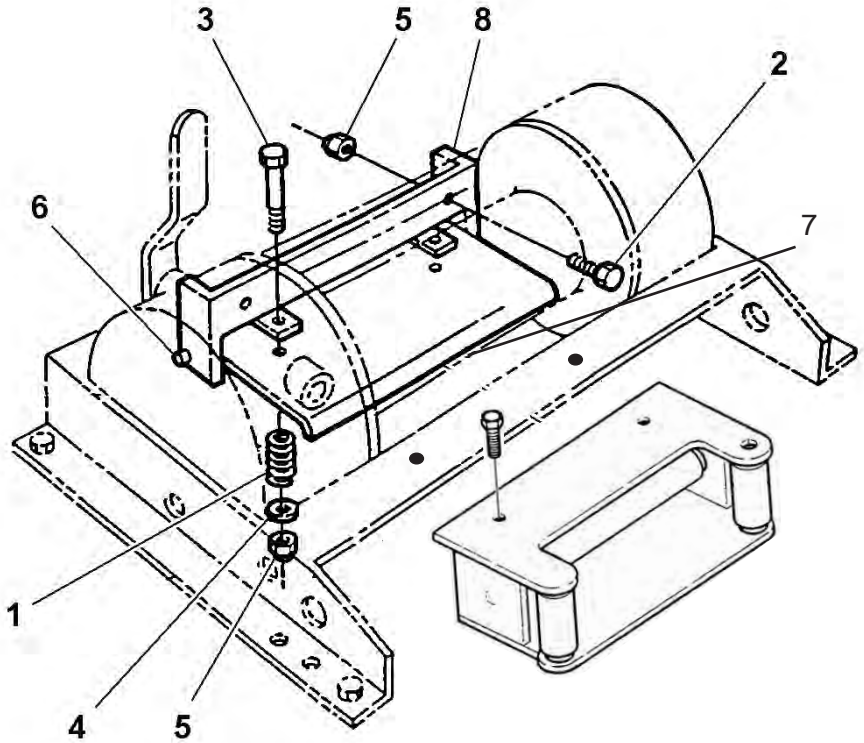

REF. NO.	NO. REQ'D	PART NUMBER	DESCRIPTION
1	2	0301729	TENSIONING SPRING
2	2	0400126	SCREW, 3/8"-16 x 1" HEX HD CAP
3	2	0400130	SCREW, 3/8"-16 x 3-1/2" HEX HD CAP
4	2	0400480	WASHER, 3/8" FLAT
5	4	0400392	NUT, 3/8"-16 HEX NYLOK
6	2	0400554	ROLL PIN, 3/8" x 1"
7	1	0800908	TENSIONING PLATE
8	1	0800909	CABLE TENSIONER BRACKET
	1	124001329	CABLE TENSIONER ASSEMBLY

Section VI - PARTS

CABLE ROLLER ASSEMBLY

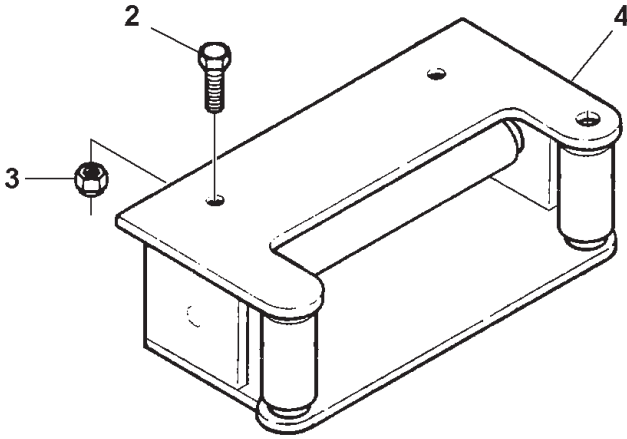

REF. NO.	NO. REQ'D	PART NUMBER	DESCRIPTION
1	--	0900892	CABLE ROLLER ASSEMBLY
2	2	0400177	SCREW, 1/2"-13 x 1-1/4" HEX HD
3	2	0400408	NUT, 1/2"-13 NYLOK
4	1	0805037	CABLE ROLLER GUIDE WELDMENT

Section VI - PARTS

WARN WINCH - MANUAL FREE SPOOL

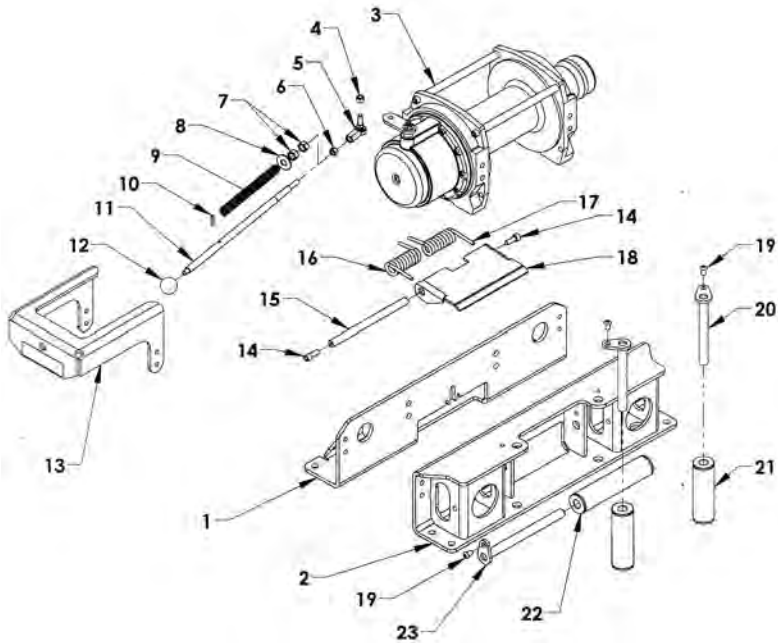

REF. NO.	NO. REQ'D	PART NUMBER	DESCRIPTION
1	1	0809644	MTG FRAME WELDMENT - FRONT
2	1	0809639	MTG FRAME WLDMNT - ROLLER GUIDE REAR
3	1	0308936-0908AM	WINCH 9K, 8 IN. DRUM MANUAL SHIFT
	1	0308936-1208AM	WINCH 12K, 8 IN. DRUM MANUAL SHIFT
4	1		NYLON LOCK NUT 3/8-16 UNC
5	1	718732	ROD END BEARING
6	1		HEX NUT 3/8-16 UNC
7	2		HEX NUT 1/2-13 UNC
8	1		FLAT WASHER 1/2
9	1	71875	WINCH SPRING
10	1		SPLIT PIN 3/16 x 1
11	1	71873	WINCH CLUTCH ROD
12	1	718731	WINCH CLUTCH ROD KNOB
13	1	0751267	WINCH - MANUAL FREE SPOOL BRACKET
14	2		BOLT, SHCS 3/8-16 UNC x 1
15	1	0751337	TENSION PLATE PIVOT ROD
16	1	71W73827	TENSION SPRING
17	1	71W73826	TENSION SPRING
18	1	0751268	TENSION PLATE
19	3		BOLT, BHCS 3/8-16 UNC x 5/8
20	2	0809641	ROLLER GUIDE KEEPER PIN
21	2	0809640	ROLLER GUIDE BUSHING 1.75 x 7.875
22	1	A9R281	ROLLER GUIDE BUSHING 1.75 x 5.625
23	1	A902095	ROLLER GUIDE KEEPER PIN

Section VI - PARTS

WARN WINCH - AIR FREE SPOOL

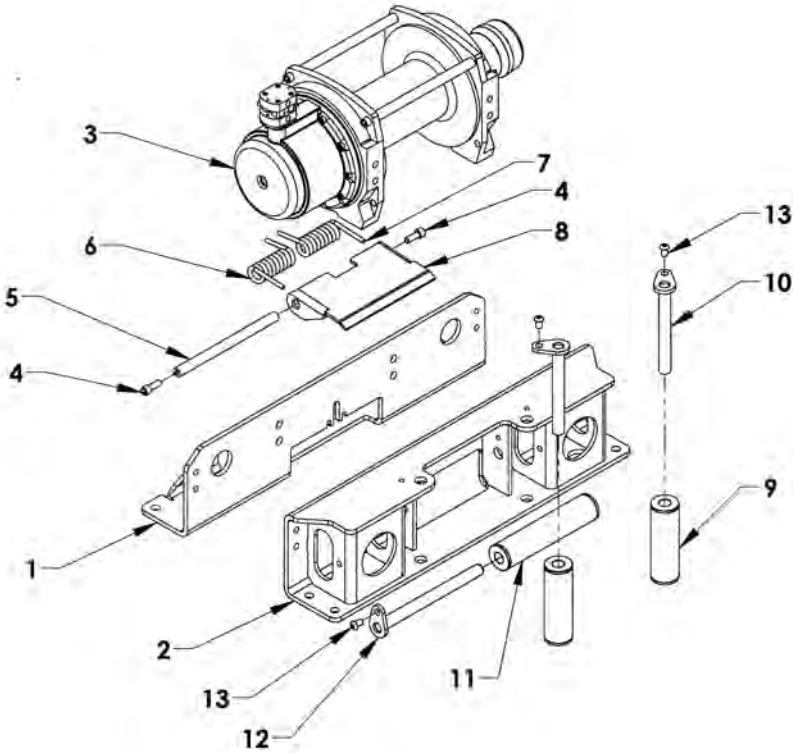

REF. NO.	NO. REQ'D	PART NUMBER	DESCRIPTION
1	1	0809644	MTG FRAME WELDMENT - FRONT
2	1	0809639	MTG FRAME WLDMNT - ROLLER GUIDE REAR
3	1	0308936-0908AA	WARN WINCH, 9K, 8 IN. DRUM, AIR SHIFT
	1	0308936-1208AA	WARN WINCH - 12K, 8 IN. DRUM, AIR SHIFT
4	1	-	BOLT, SHCS 3/8-16 UNC x 1
5	1	0751337	WARN TENSION PLATE PIVOT ROD
6	1	71W73827	WARN TENSION SPRING
7	2	71W73826	WARN TENSION SPRING
8	1	0751268	WARN TENSION PLATE
9	1	0809640	ROLLER GUIDE BUSHING 1.75 x 7.875
10	1	0809641	ROLLER GUIDE KEEPER PIN
11	1	A9R281	ROLLER GUIDE BUSHING 1.75 x 5.625
12	1	A902095	ROLLER GUIDE KEEPER PIN
13	1	-	BOLT, BHCS 3/8-16 UNC x 5/8

Section VI - PARTS

RAMSEY H400 WINCH GROUP

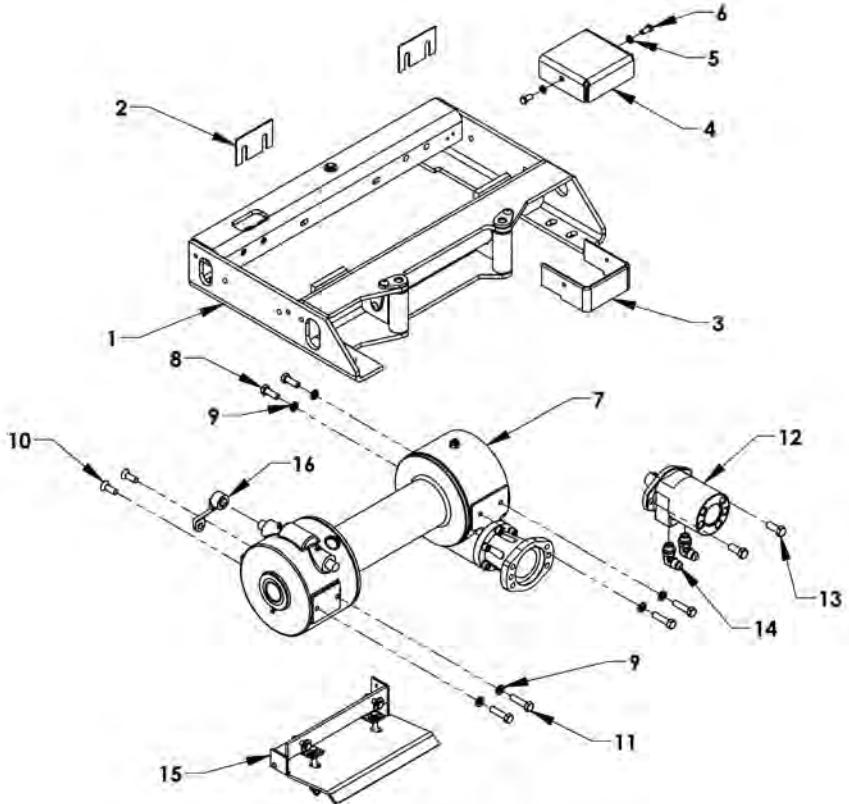

REF. NO.	NO. REQ'D	PART NUMBER	DESCRIPTION
1	1	0940349	RAMSEY H400 MOUNTING FRAME
2	2	0701272-H400	SHIM-
3	1	0752151	RAMSEY MOTOR GUARD-VERTICAL CHANNEL
4	1	0752152	MOTOR GUARD COVER PLATE
5	2	-	WASHER 3/8 LOCK
6	2	-	BOLT - HEX 3/8-16 x 3/4
7	1	0302149	RAMSEY H400 WINCH
8	2	-	BOLT- HEX 7/16-14 UNC x 1-1/4
9	10	-	WASHER 7/16 LOCK
10	2	-	BOLT - FSCS 7/16-14 UNC x 3/4
11	4	-	BOLT - HEX 7/16-14 UNC x 1-3/4
12	1	0302148	RAMSEY H400 WINCH MOTOR
13	2	-	BOLT - HEX 1/2-13 UNC x 1-1/4
14	2	ADPTR2062-08X08	
15	1	0901196	CABLE TENSIONER ASSEMBLY
16	1	0809705	BELL CRANK WELDMENT - RAMSEY H400

Section VI - PARTS

BODY LOCK ASSEMBLY - 364220K

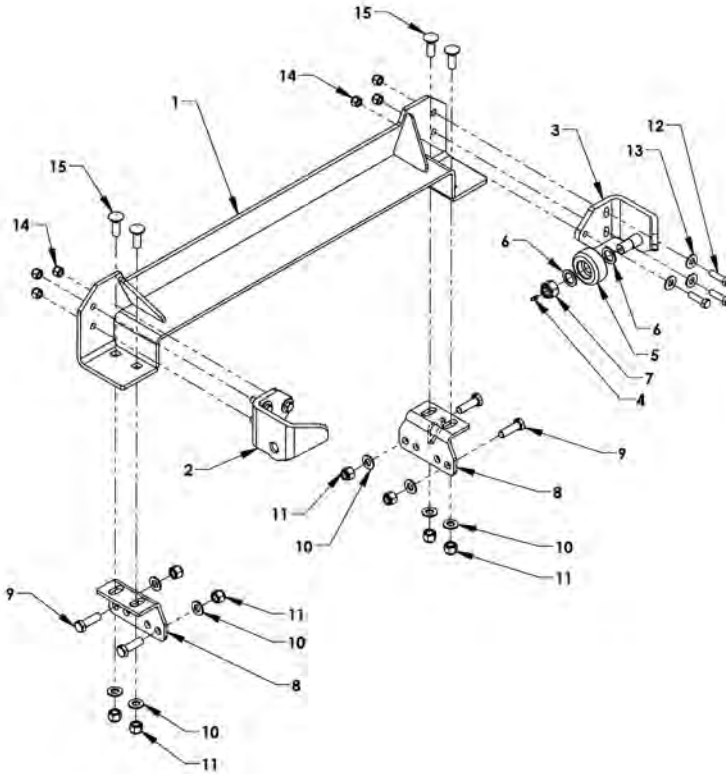

REF. NO.	NO. REQ'D	PART NUMBER	DESCRIPTION
1	1	364220	LCG BODY LOCK WELDMENT-SETBACK CAPABLE
2	1	36315L	BODY LOCK HOLD-DOWN - LEFT
3	1	36315R	BODY LOCK HOLD-DOWN - RIGHT
4	2	7B130	GREASE FITTING 1/4-28
5	2	36310	ROLLER WHEEL
6	4		FLAT WASHER 1
7	2		NYLON LOCK NUT, 7/8-14 UNF
8	2	0809183	MOUNTING BRACKET
9	4		BOLT, 5/8-11 HHCS UNC x 2 GRADE 5
10	8		FLAT WASHER 5/8
11	8		NYLON LOCK NUT, 5/8-11 UNC
12	6		BOLT, HHCS 1/2-20 UNF x 1-1/4
13	6		FLAT WASHER, 1/2 IN.
14	6		NYLON LOCK NUT, 1/2-20 UNF
15	4		CARRIAGE BOLT 5/8-11 x 1-3/4

Section VI - PARTS

DIRECT MOUNT PUMP - 18 GPM

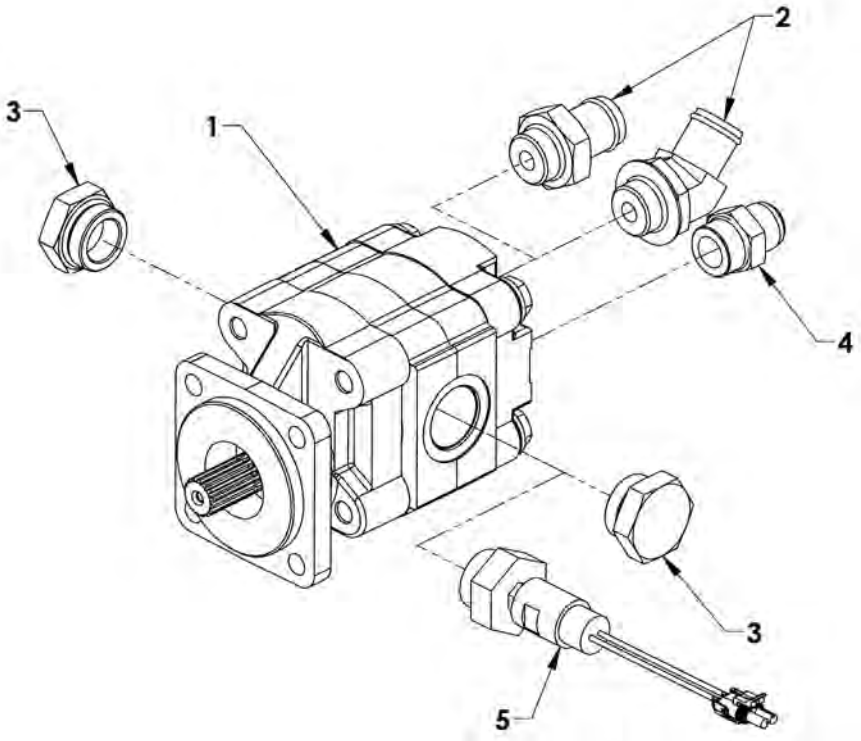

REF	PART #	DESCRIPTION	QPU
1	0320144	18 GPM , 1 IN.15 SPLINE SHAFT, SAE 4-BOLT FLANGE	1
2	S14604-20 x 16	#16-45 M O-RING x 1-1/4 M NIPPLE	1
	S14603- 20 x 26F	#16 M O-RING x 1-1/4 NIPPLE	1
3	77620	1-1/4 O-RING PLUG 900598-20	2
4	779A7	#16 M O-RING X 3/4 MJIC	1
5	0909434	PRESSURE TRANSDUCER (OPTIONAL)	1

Section VI - PARTS

MUDFLAP COMPONENTS

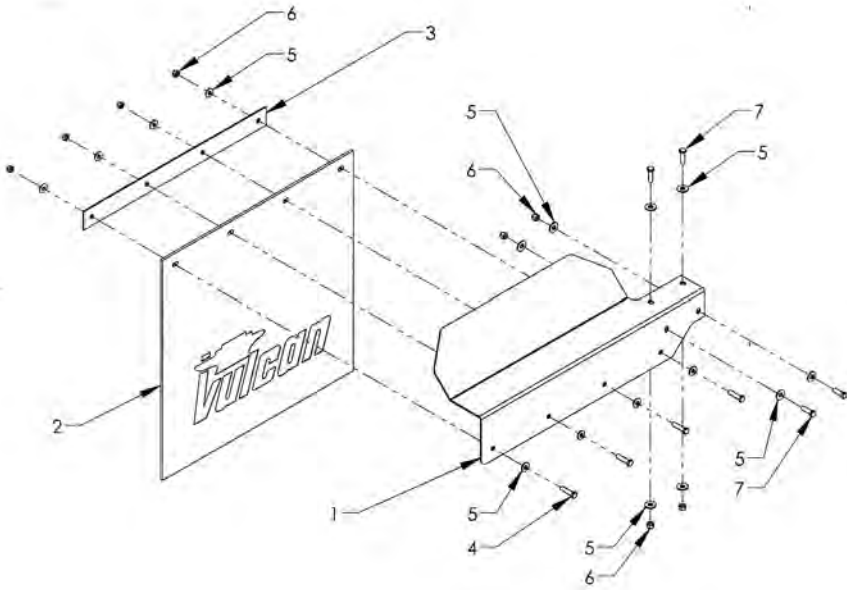

REFPART #	DESCRIPTION	QPU
1	0751034L MUDFLAP MOUNTING BRACKET (LH)	1
	0751034R MUDFLAP MOUNTING BRACKET (RH)	1
2	9033233 MUDFLAP 24 x 24	1
3	0750340 MUDFLAP SUPPORT BAR	1
4	BOLT HHCS 3/8-16 UNC x 1-1/2	4
5	3/8 FLAT WASHER	16
6	3/8-16 NYLON LOCK NUT	16
7	BOLT HHCS 3/8-16 UNC x 1-1/4	4

Section VI - PARTS

OPTIONAL DASHBOARD PANEL

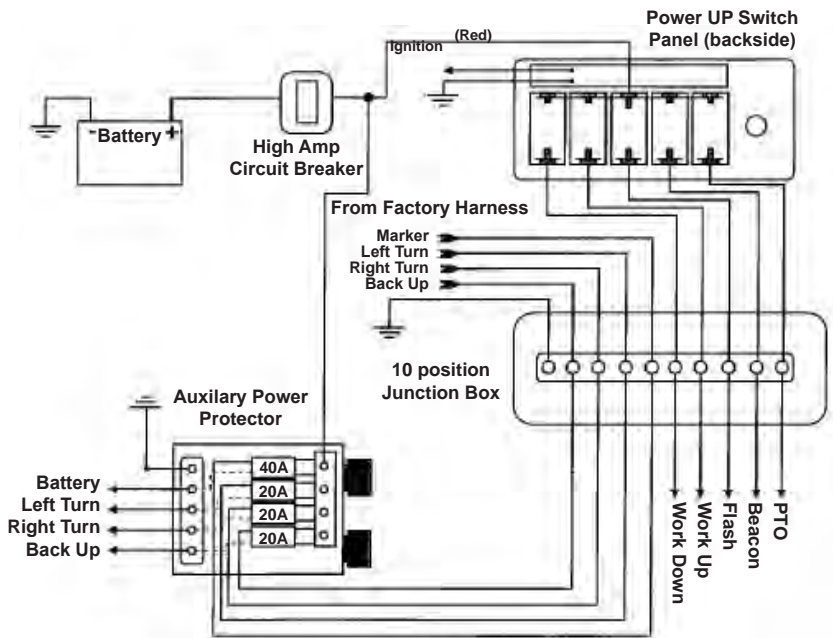

Section VI - PARTS

LIGHT KIT



REF. NO.	PART NUMBER	DESCRIPTION
1	0311498	LIGHT 6" OVAL RED LED - STOP/TURN
2	0311500	LIGHT 6" OVAL REVERSE LED
3	3011503	LIGHT 6" GROMMET

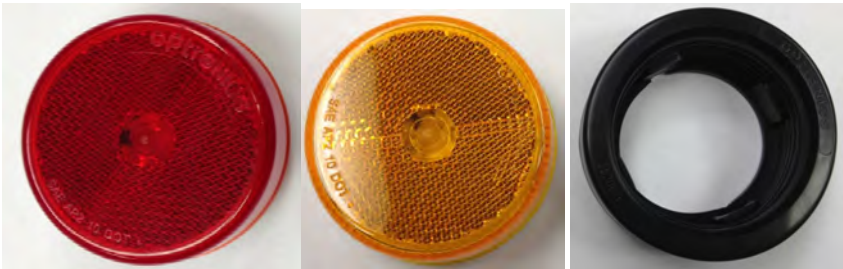

REF. NO.	PART NUMBER	DESCRIPTION
1	0311512	LIGHT 2.5" RED REFLEX LED (MCL59RB)
2	0311513	LIGHT 2.5" AMBER REFLEX LED (MCL59AB)
3	0311516	LIGHT 2.5" GROMMET

Section VI - PARTS

LIGHT KIT



REF. NO.	PART NUMBER	DESCRIPTION
1	0311514	LIGHT 2.5" ROUND CLEAR/RED LED MARKER LIGHT
2	0311515	LIGHT 2.5" ROUND CLEAR/AMBER LED MARKER LIGHT
3	3011516	LIGHT 2.5" GROMMET



REF. NO.	PART NUMBER	DESCRIPTION
1	97300	CONTROL STATION LIGHT

Section VI - PARTS

LIGHT KIT



REF. NO.	PART NUMBER	DESCRIPTION
1	0311519	RED 3/4 LED ICC LIGHT



REF. NO.	PART NUMBER	DESCRIPTION
1	0311520	RED 3/4 LED LIGHT

Section VI - PARTS

LIGHT KIT



REF. NO.	PART NUMBER	DESCRIPTION
1	0311521	AMBER 3/4 ROUND LED LIGHT



REF. NO.	PART NUMBER	DESCRIPTION
1	0311522	CLEAR/RED 3/4 ROUND LED LIGHT



REF. NO.	PART NUMBER	DESCRIPTION
1	0311523	CLEAR/AMBER 3/4 ROUND LED LIGHT

Section VI - PARTS

LIGHT KIT



REF. NO.	PART NUMBER	DESCRIPTION
1	0308359	MARKER LIGHT RED REFLEX LED



REF. NO.	PART NUMBER	DESCRIPTION
1	0308360	MARKER LIGHT AMBER REFLEX LED

Section VI - PARTS

LIGHT KIT



REF. NO.	PART NUMBER	DESCRIPTION
1	0308969R	MARKER LIGHT RED REFLEX LED



REF. NO.	PART NUMBER	DESCRIPTION
1	0308969A	MARKER LIGHT AMBER REFLEX LED

Section VI - PARTS

LIGHT KIT



REF. NO.	PART NUMBER	DESCRIPTION
1	074027041ACL	MILLENIUM MARKER LIGHT CLEAR/AMBER



REF. NO.	PART NUMBER	DESCRIPTION
1	174027041RCL	MELLIENUM MARKER LIGHT CLEAR/RED

Section VI - PARTS

LIGHT KIT



REF. NO.	PART NUMBER	DESCRIPTION
1	0308491	REFLECTOR - AMBER



REF. NO.	PART NUMBER	DESCRIPTION
1	0308490	REFLECTOR - RED

Section VI - PARTS

LIGHT KIT

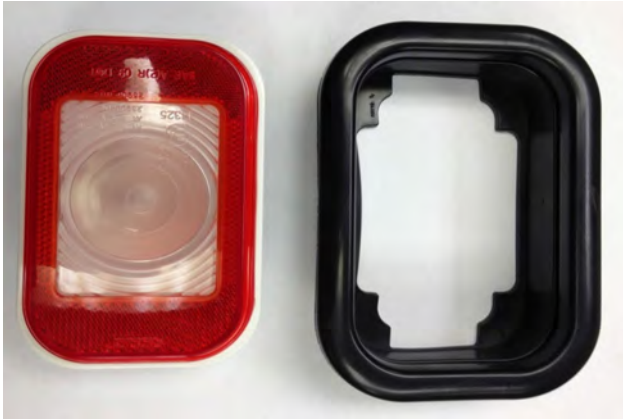

REF. NO.	PART NUMBER	DESCRIPTION
1	0311510	RECTANGULAR REFLEX BACK UP
1	0311511	RECTANGULAR REFLEX BACK UP GROMMET

Section VI - PARTS

MANUAL SLIDEWINDER

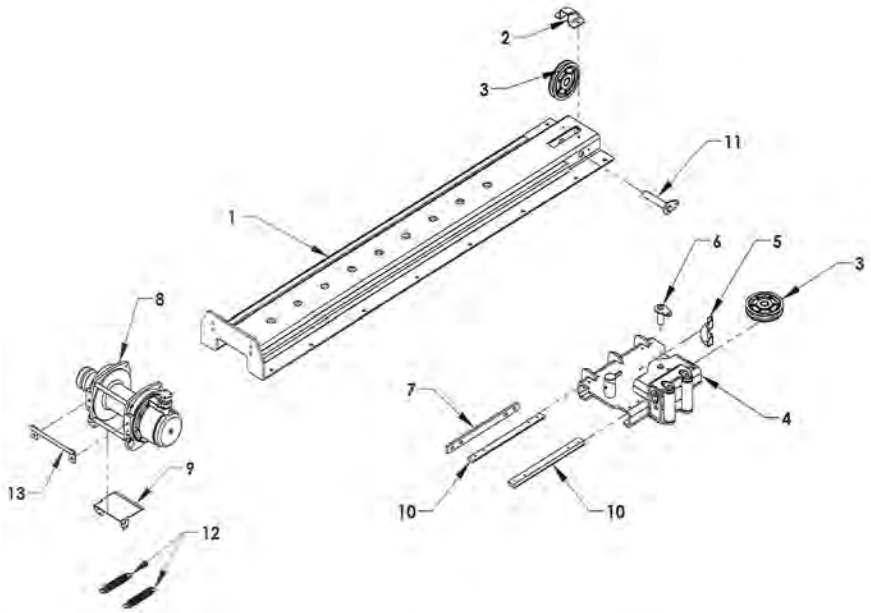

REF. NO.	NO. REQ'D	PART NUMBER	DESCRIPTION
1	1	315214	SLIDE TRACK - LONG
2	1	315225	CABLE GUIDE
3	2	69125	6 x 1 PULLEY
4	1	315310	SLIDE CARRIAGE
5	1	315325	CABLE GUIDE
6	1	315330	PULLEY PIN
7	1	315323	FRONT SLIDE PAD
8	1	711096	SERIES 9 WINCH - 6.5 INCH DRUM
	1	711126	SERIES 12 WINCH - 6.5 INCH DRUM
9	1	A90065	CABLE TENSIONER PLATE
10	2	315320	SLIDE PAD
11	1	315230	PULLEY PIN
12	2	A90185	CABLE TENSIONER SPRING
13	1	7189065	AIR LINE TRANSFER BRACKET

Section VI - PARTS

LCG RETRACTABLE LADDER

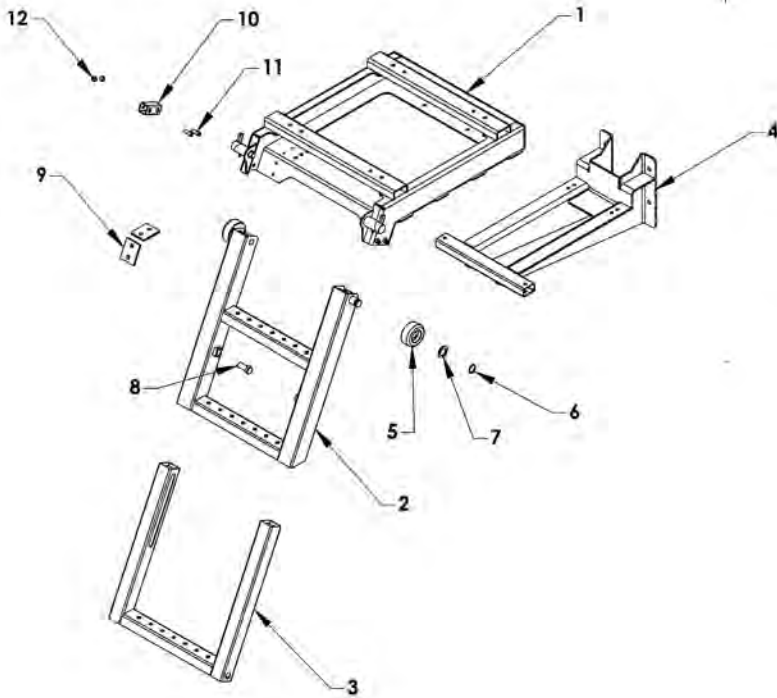

REF	PART #	DESCRIPTION	
	390000	LADDER ASSEMBLY	1
1	391010	LADDER CARRIAGE	1
2	391020	UPPER RUNG ASSEMBLY	1
3	391030	LOWER RUNG ASSEMBLY	1
4	391050	FRAME MOUNTING BRACKET - OPTIONAL	1
5	36310	WHEEL	2
6	86100E	RETAINING RING 1.00 EXTERNAL	2
7	82710	FLAT WASHER 1 x 1.50	2
8	391026	RETAINING BOLT 5/8-11 x 1-1/2	2
9	391018	WEAR PAD	4
10	391015	RETAINING TUBE	2
11	81211	ALLEN HEAD BOLT 3/8-16 x 1	4
12	83211	NYLON LOCK NUT 3/8-16	4

Section VI - PARTS

33" ALUMINUM TOOLBOX - 377000

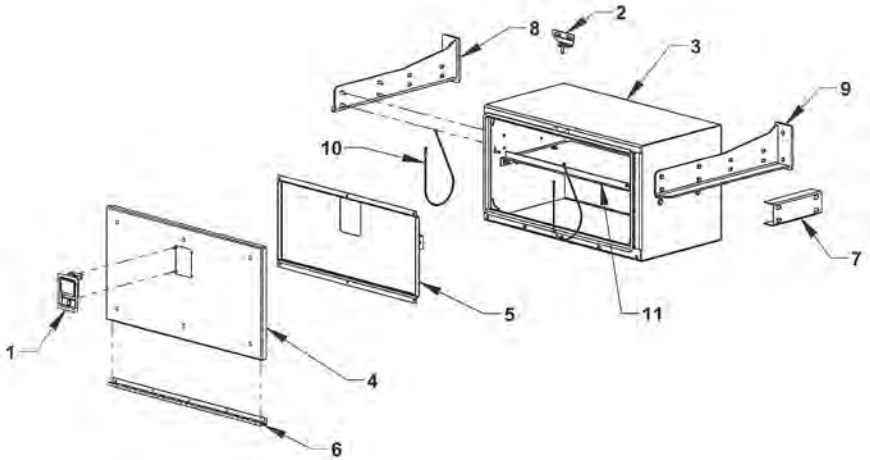

REF	PART #	DESCRIPTION	QPU
1	54658	ROTARY PADDLE LATCH	1
	54657	GASKET FOR PADDLE LATCH	1
	81111	#8-32 X 1/2 STAINLESS ONE WAY SCREW	4
	83111	#8-32 STAINLESS KEPT NUT	4
2	376182	STRIKER PIN MOUNTING PLATE	1
	54659	STRIKER PIN	1
	81115	STAINLESS CARRIAGE BOLT 5/16-18 x 3/4	2
	82110	FLAT WASHER 5/16	4
	82130	LOCK WASHER 5/16	2
	83110	NUT 5/16-18	2
	83125	NYLON LOCK NUT 5/16-18	1
	377100W	BOX WELDMENT	1
4	37741	DOOR WELDMENT	1
	37740	DOOR ASSEMBLY	1
	81100	STAINLESS CARRIAGE BOLT 1/4-20 x 3/4	6
	83105	NYLON LOCK NUT 1/4-20	6
	37744	DOOR REINFORCEMENT	1
6	37735	HINGE	1
	811014	SS SOCKET BUTTON HEAD BOLT 1/4-20 x 7/8	2
	811012	SS SOCKET BUTTON HEAD BOLT 1/4-20 x 3/4	3
	811010	SS SOCKET BUTTON HEAD BOLT 1/4-20 x 5/8	5
	83105	NYLON LOCK NUT 1/4-20	10
7	37760	TANDEM BOX SPACER CHANNEL (OPTIONAL)	1
8	37855R	TANK AND TOOLBOX MT BRACKET-RIGHT	1
9	37855L	TANK AND TOOLBOX MT BRACKET-LEFT	1
10	5A221	LANYARD-21 INCH	2
11	37770	SHELF	1

Section VI - PARTS

49" ALUMINUM TOOLBOX - 378000

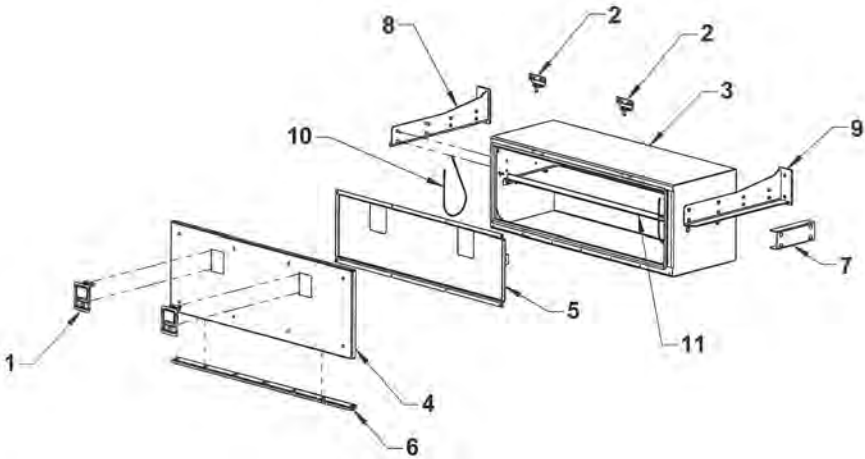

REF	PART #	DESCRIPTION	QPU
1	54658	ROTARY PADDLE LATCH	2
	54657	GASKET FOR PADDLE LATCH	2
	81111	#8-32 X 1/2 STAINLESS ONE WAY SCREW	8
	83111	#8-32 STAINLESS KEPT NUT	8
2	376182	STRIKER PIN MOUNTING PLATE	2
	54659	STRIKER PIN	2
	81115	STAINLESS CARRIAGE BOLT 5/16-18 x 3/4	4
	82110	FLAT WASHER 5/16	8
	82130	LOCK WASHER 5/16	4
	83110	NUT 5/16-18	4
	83125	NYLON LOCK NUT 5/16-18	2
	378100W	BOX WELDMENT	1
4	37841	DOOR WELDMENT	1
	37840	DOOR ASSEMBLY	1
	81100	STAINLESS CARRIAGE BOLT 1/4-20 x 3/4	8
	83105	NYLON LOCK NUT 1/4-20	8
	37844	DOOR REINFORCEMENT	1
6	37835	HINGE	1
	811014	SS SOCKET BUTTON HEAD BOLT 1/4-20 x 7/8	2
	811012	SS SOCKET BUTTON HEAD BOLT 1/4-20 x 3/4	5
	811010	SS SOCKET BUTTON HEAD BOLT 1/4-20 x 5/8	7
	83105	NYLON LOCK NUT 1/4-20	14
7	37760	TANDEM BOX SPACER CHANNEL (OPTIONAL)	1
8	37855R	TANK AND TOOLBOX MT BRACKET-RIGHT	1
9	37855L	TANK AND TOOLBOX MT BRACKET-LEFT	1
10	5A221	LANYARD-21 INCH	2
11	37770	SHELF	1

Section VI - PARTS

65" ALUMINUM TOOLBOX - 379000

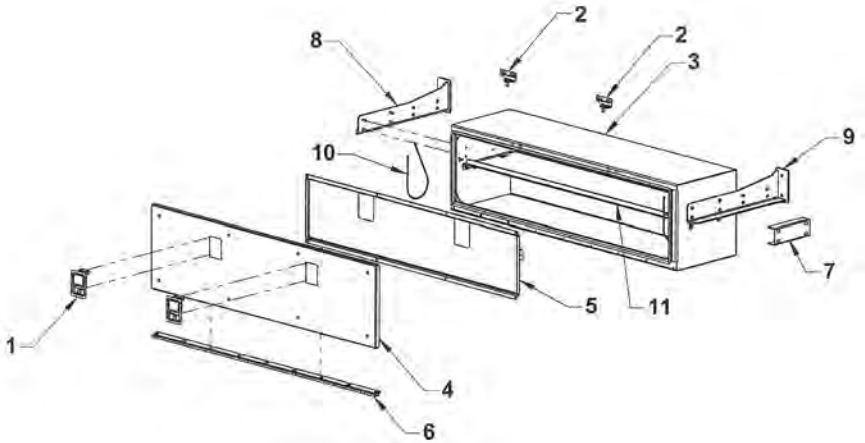

REF	PART #	DESCRIPTION	QPU
1	54658	ROTARY PADDLE LATCH	2
	54657	GASKET FOR PADDLE LATCH	2
	81111	#8-32 X 1/2 STAINLESS ONE WAY SCREW	8
	83111	#8-32 STAINLESS KEPT NUT	8
2	376182	STRIKER PIN MOUNTING PLATE	2
	54659	STRIKER PIN	2
	81115	STAINLESS CARRIAGE BOLT 5/16-18 x 3/4	4
	82110	FLAT WASHER 5/16	8
	82130	LOCK WASHER 5/16	4
	83110	NUT 5/16-18	4
	83125	NYLON LOCK NUT 5/16-18	2
	379100W	BOX WELDMENT	1
4	37941	DOOR WELDMENT	1
	37940	DOOR ASSEMBLY	1
	81100	STAINLESS CARRIAGE BOLT 1/4-20 x 3/4	8
	83105	NYLON LOCK NUT 1/4-20	8
	37944	DOOR REINFORCEMENT	1
6	37935	HINGE	1
	811014	SS SOCKET BUTTON HEAD BOLT 1/4-20 x 7/8	2
	811012	SS SOCKET BUTTON HEAD BOLT 1/4-20 x 3/4	7
	811010	SS SOCKET BUTTON HEAD BOLT 1/4-20 x 5/8	9
	83105	NYLON LOCK NUT 1/4-20	18
7	37760	TANDEM BOX SPACER CHANNEL (OPTIONAL)	1
8	37855R	TANK AND TOOLBOX MT BRACKET-RIGHT	1
9	37855L	TANK AND TOOLBOX MT BRACKET-LEFT	1
10	5A221	LANYARD-21 INCH	2
11	37770	SHELF	1

Section VI - PARTS

BED MOUNTED CAB PROTECTOR

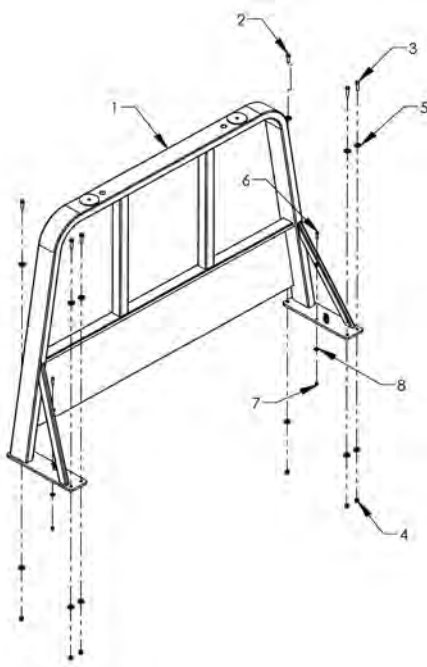

REF. NO.	NO. REQ'D	PART NUMBER	DESCRIPTION
1	1	0809558-38	2 x 5 PERIMETER TUBE CAB PROTECTOR - 38"
		0809558-42	2 x 5 PERIMETER TUBE CAB PROTECTOR - 42"
		0809558-45	2 x 5 PERIMETER TUBE CAB PROTECTOR - 45"
		0809558-48	2 x 5 PERIMETER TUBE CAB PROTECTOR - 48"
		0809558-50	2 x 5 PERIMETER TUBE CAB PROTECTOR - 50"
		0809558-52	2 x 5 PERIMETER TUBE CAB PROTECTOR - 52"
		0809558-54	2 x 5 PERIMETER TUBE CAB PROTECTOR - 54"
		0809558-57	2 x 5 PERIMETER TUBE CAB PROTECTOR - 57"
		0809558-60	2 x 5 PERIMETER TUBE CAB PROTECTOR - 60"
0809558-64	2 x 5 PERIMETER TUBE CAB PROTECTOR - 64"		
2	2	0400211	1/2 -13 x 1-3/4 HHCS GR 5 Z
3	4	0400188	1/2 -13 x 2 HHCS
4	6	0400408	1/2 -13 NYLON LOCK NUT ZINC
5	12	0400492	1/2 USS FLAT WASHER ZINC
6	2	0400132	3/8 -16 x 1-1/2 HHCS GR 5 Z
7	2	0400392	3/8 -16 NYLON LOCK NUT ZINC
8	4	0400480	3/8 - USS FLAT WASHER ZINC

Section VIII - SCHEMATICS

HYDRAULICS

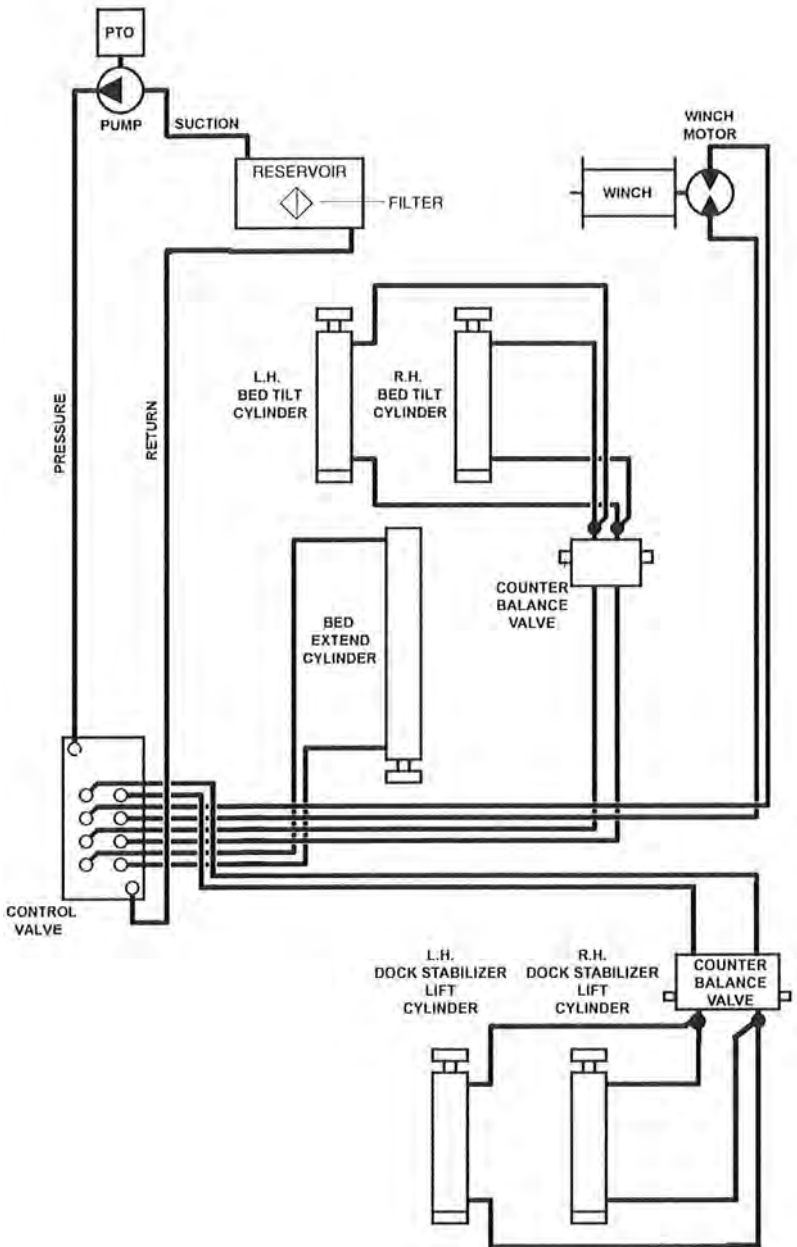

Section VIII - SCHEMATIC WIRELESS AIR ACTUATED REMOTE CONTROLS

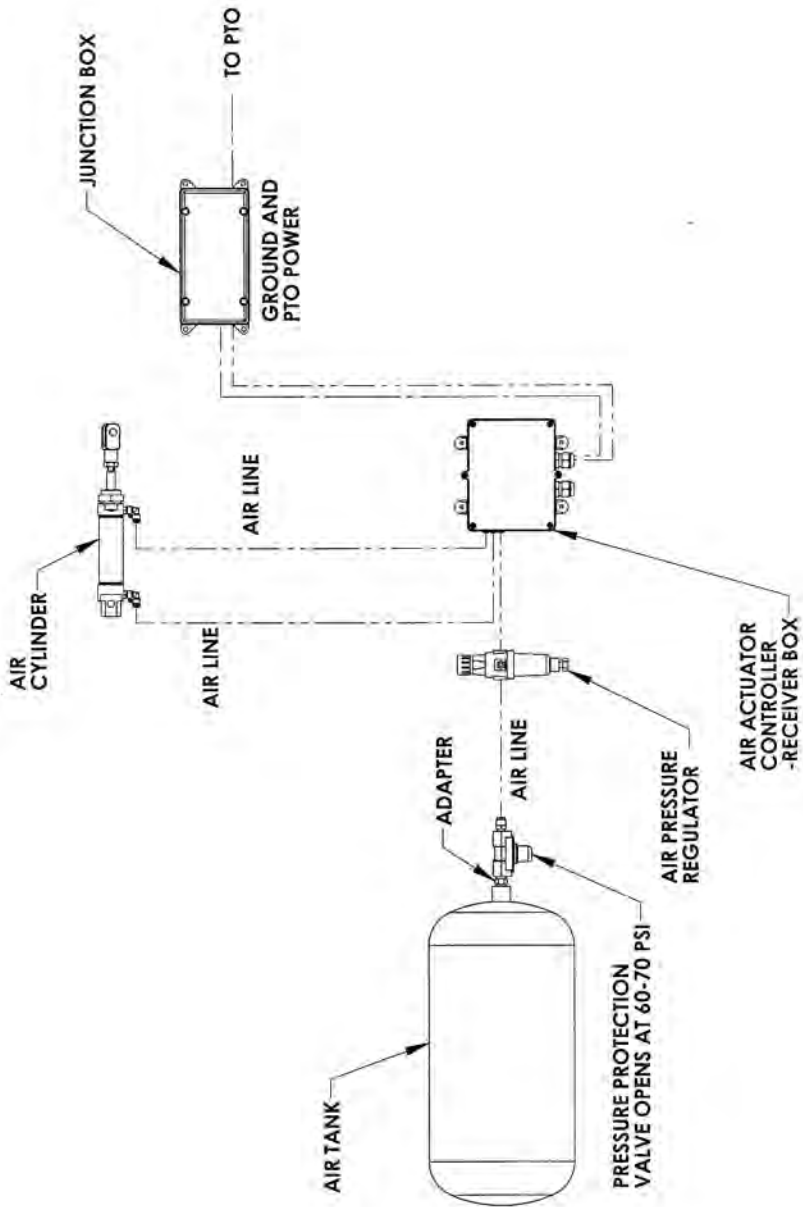

Section VIII - SCHEMATICS

CONTROL VALVE REMOTE CONTROL WINCH WIRE DIAGRAM

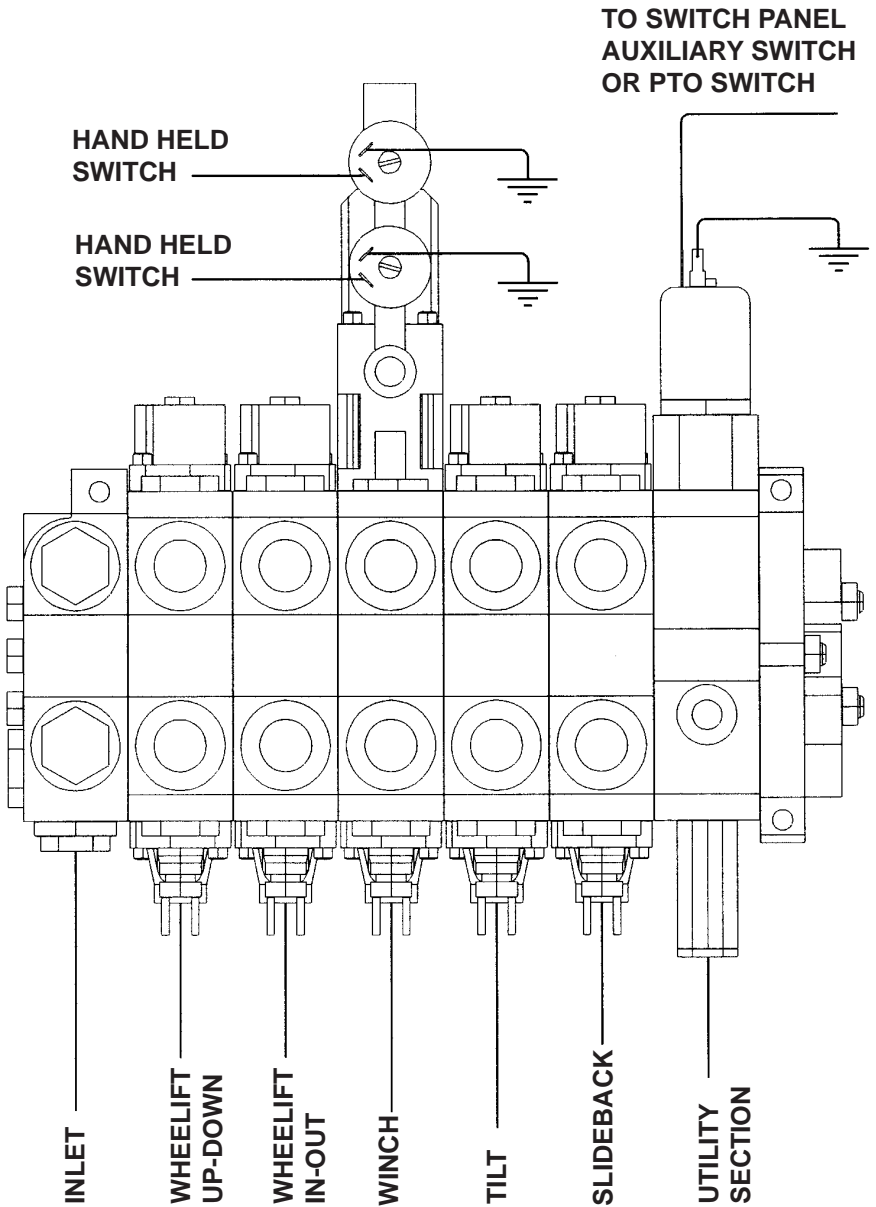

Section VIII - SCHEMATICS
CAR CARRIER
L-ARM CYLINDER HOSE ROUTING
AUTOGRIP II

Yellow is divided flow for right arm close.
 Green is divided flow for left arm close
 Purple is return combined flow.

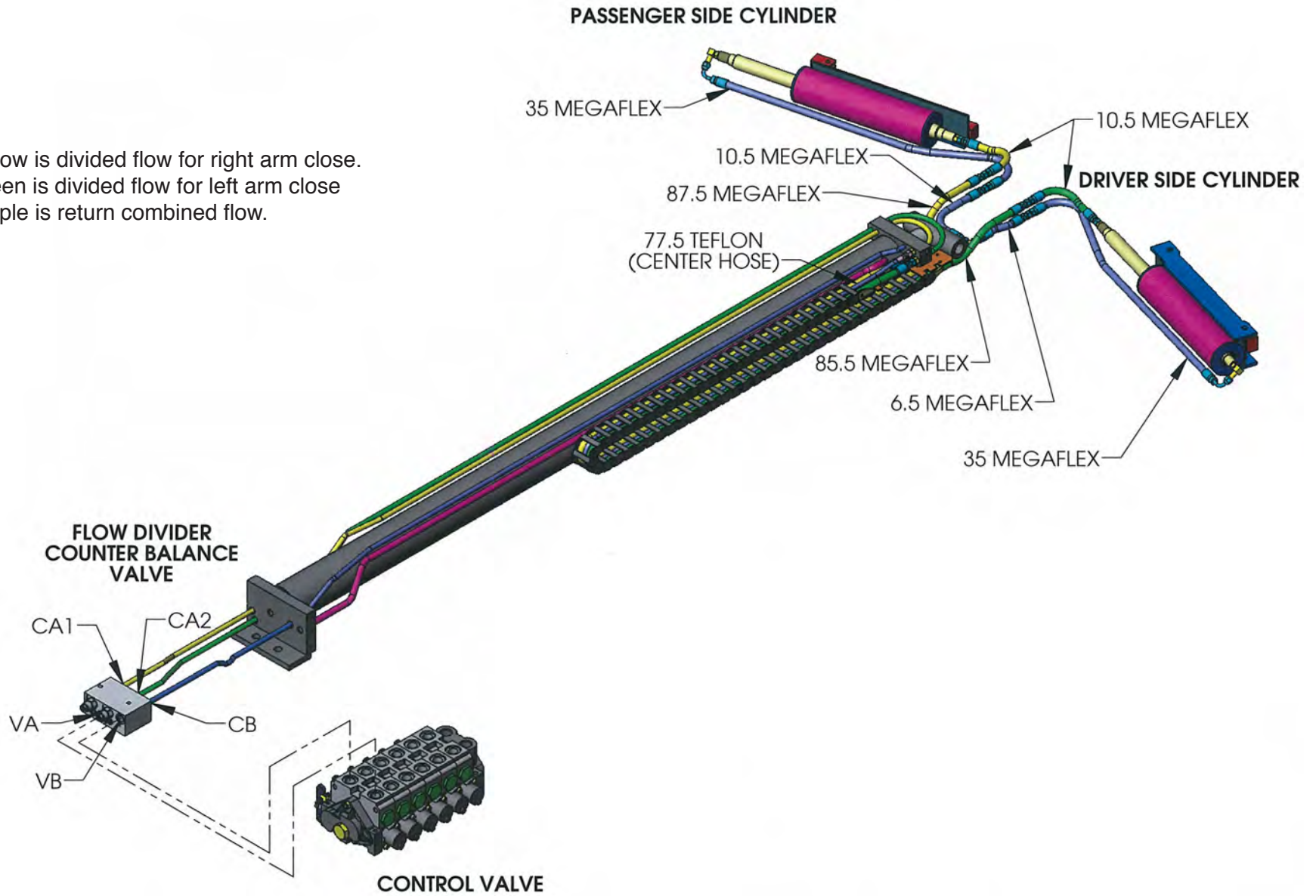

Section VIII- SCHEMATICS

CAR CARRIER

L-ARM CYLINDER HOSE ROUTING

AUTOGRIP II

