

51 Winthrop Road
Chester, Connecticut 06412-0684
Phone: (860) 526-9504
Sales Email: autosale@whelen.com
Canadian Sales: canadiansales@whelen.com
Customer Service: custserv@whelen.com

Safety First: This document provides all the necessary information to allow your Whelen product to be properly and safely installed. Before beginning the installation and/or operation of your new product, the installation technician and operator must read this manual completely. Important information is contained herein that could prevent serious injury or damage.

- Proper installation of this product requires the installer to have a good understanding of automotive electronics, systems and procedures.
- Whelen Engineering requires the use of waterproof butt splices and/or connectors if that connector could be exposed to moisture.
- Any holes, either created or utilized by this product, should be made both air- and watertight using a sealant recommended by your vehicle manufacturer.
- Failure to use specified installation parts and/or hardware will void the product warranty!
- If mounting this product requires drilling holes, the installer **MUST** be sure that no vehicle components or other vital parts could be damaged by the drilling process. Check both sides of the mounting surface before drilling begins. Also de-burr any holes and remove any metal shards or remnants. Install grommets into all wire passage holes.
- Do not install this product or route any wires in the deployment area of your air bag. Equipment mounted or located in the air bag deployment area will damage or reduce the effectiveness of the air bag, or become a projectile that could cause serious personal injury or death. Refer to your vehicle owner's manual for the air bag deployment area. The User/Installer assumes full responsibility to determine proper mounting location, based on providing ultimate safety to all passengers inside the vehicle.
- For this product to operate at optimum efficiency, a good electrical connection to chassis ground must be made. The recommended procedure requires the product ground wire to be connected directly to the **NEGATIVE (-)** battery post.
- If this product uses a remote device to activate or control this product, make sure that this control is located in an area that allows both the vehicle and the control to be operated safely in any driving condition.
- Do not attempt to activate or control this device in a hazardous driving situation.
- This product contains either strobe light(s), halogen light(s), high-intensity LEDs or a combination of these lights. Do not stare directly into these lights. Momentary blindness and/or eye damage could result.
- Use only soap and water to clean the outer lens. Use of other chemicals could result in premature lens cracking (crazing) and discoloration. Lenses in this condition have significantly reduced effectiveness and should be replaced immediately. Inspect and operate this product regularly to confirm its proper operation and mounting condition. Do not use a pressure washer to clean this product.
- **WARNING!** All customer supplied wires that connect to the positive (+) terminal of the battery must be sized to supply at least 125% of the maximum operating current and **FUSED** "at the battery" to carry that load. **DO NOT USE CIRCUIT BREAKERS WITH THIS PRODUCT!**
- **FAILURE TO FOLLOW THESE PRECAUTIONS AND INSTRUCTIONS COULD RESULT IN DAMAGE TO THE PRODUCT OR VEHICLE AND/OR SERIOUS INJURY TO YOU AND YOUR PASSENGERS!**

NOTICE! Prior to installing on any vehicle, check your state motor vehicle codes to confirm that this product complies with any and all state statutes.

Installation: Refer to the diagrams shown for mounting measurements specific to your model.

IMPORTANT: Customer supplied wire must be a minimum of 18 gauge.

5FLANGE* Notes: Mark the mounting and cut out holes onto the mounting surface. Drill the 2 mounting holes to the sizes noted and remove the area that the lighthouse fits into. Thread the wires through the rubber gasket and extend to your power source. Attach the housing to vehicle using the flange and supplied mounting hardware. Extend the wires to your power source.

5TSMAS* and 5LSMAS* Notes: Mark off the measurements and drill the wire access and mounting holes. Thread the wires through the rubber gasket, through the wire access hole and to your power source. Attach housing to vehicle using supplied mounting hardware and flange. Extend the wires to your power source.

5GROMMET Notes: Mark off the measurements, drill the two 1.25" holes and cut out the center area. Install the rubber grommet. Assemble the flange, lighthouse and adapter then snap this assembly into the grommet. Extend the wires to your power source.

Wiring

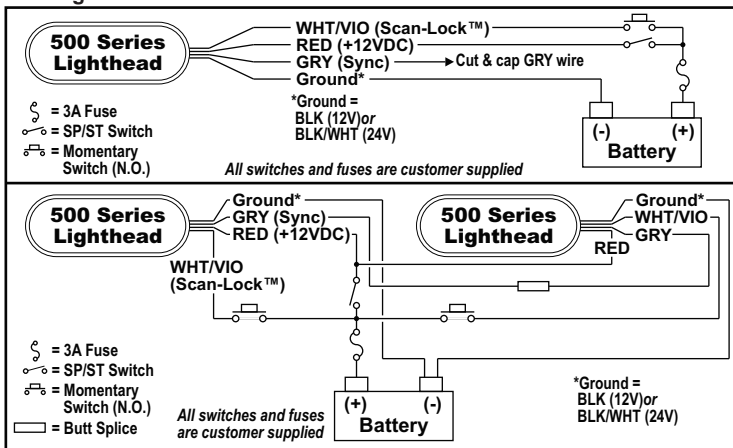

Scan-Lock™: To advance pattern: With the lighthouse active, apply +VBAT to the WHT/VIO wire for less than 1 second. To cycle to previous patterns: Apply +VBAT for more than 1 second. To restore factory default pattern: Turn off power to the lighthouse. Apply +VBAT to the WHT/VIO wire while turning the lighthouse on. Continue to apply voltage to the WHT/VIO wire for 5 seconds.

SYNC Operation: Some of the patterns available for the standard SYNC lighthouse are described as being either Phase 1 (PH.1) or Phase 2 (PH.2). These terms define how patterns on lighthouses with their SYNC wires connected relate to each other. Lighthouses configured to display the same Phase of a given pattern (Phase 1 or Phase 2) will flash simultaneously. Lighthouses configured to Phase 2 of a given pattern will alternate with Phase 1 lighthouses.

Split lighthouses have 2 additional phases. Their operation is more easily understood using the following illustration:

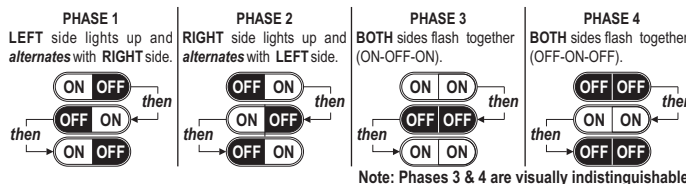

The SYNC wire can be connected to other SYNC-capable power supplies to synchronize their output. Be sure to cap the SYNC wire if it is not used.

Standard Lighthouse Patterns:

- | | | |
|-----------------------------|----------------------------|---------------------|
| 1. SignalAlert™ 75 ... PH.1 | 10. ComAlert™ 75 ... PH.2 | 19. DoubleFlash 150 |
| 2. SignalAlert™ 75 ... PH.2 | 11. LongBurst™ 75 ... PH.1 | 20. ComAlert™ 150 |
| 3. CometFlash® 75 ... PH.1 | 12. LongBurst™ 75 ... PH.2 | 21. ActionFlash™ 1 |
| 4. CometFlash® 75 ... PH.2 | 13. PingPong™ 75 ... PH.1 | 22. ActionFlash™ 2 |
| 5. DoubleFlash 75 ... PH.1 | 14. PingPong™ 75 ... PH.2 | 23. ModuFlash™ |
| 6. DoubleFlash 75 ... PH.2 | 15. SingleFlash 60 | 24. ActionScan™ |
| 7. SingleFlash 75 ... PH.1 | 16. SingleFlash 90 | 25. Steady |
| 8. SingleFlash 75 ... PH.2 | 17. SingleFlash 120 | |
| 9. ComAlert™ 75 ... PH.1 | 18. SingleFlash 300 | |

NOTE: BOLD = CA Title XIII Compliant Pattern *Italic* = SYNC Pattern

Connector Pinouts

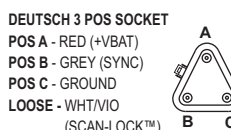

Flange Mount (5FLANGEC / 5FLANGEP / 5FLANGEB)

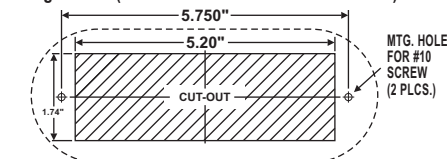

Flange Mount (5TSMAC / 5TSMAB / 5LSMAB / 5LSMAC)

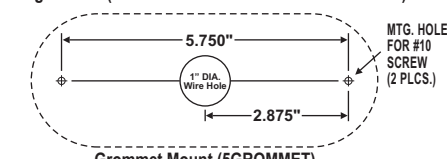

Grommet Mount (5GROMMET)

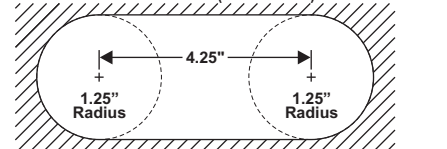

IMPORTANT! Before returning the vehicle to active service, visually confirm the proper operation of this product, as well as all vehicle components/equipment.

Split Lighthouse Patterns:

- | | | |
|-----------------------------|-----------------------------------|-----------------------------|
| 1. SignalAlert™ 75 ... PH.1 | 24. LongBurst 75 ... PH.4 | 47. ModuFlash™ ... ALT |
| 2. SignalAlert 75 ... PH.2 | 25. PingPong™ 75 ... PH.1 | 48. ModuFlash ... SIM |
| 3. SignalAlert 75 ... PH.3 | 26. PingPong 75 ... PH.2 | 49. DoubleFlash 120 ... ALT |
| 4. SignalAlert 75 ... PH.4 | 27. PingPong 75 ... PH.3 | 50. DoubleFlash 120 ... SIM |
| 5. CometFlash® 75 ... PH.1 | 28. PingPong 75 ... PH.4 | 51. PingPong™ 120 ... ALT |
| 6. CometFlash 75 ... PH.2 | 29. SSNF 75 ... PH.1 | 52. PingPong 120 ... SIM |
| 7. CometFlash 75 ... PH.3 | 30. SSNF 75 ... PH.2 | 53. TripleFlash™ 75 ... ALT |
| 8. CometFlash 75 ... PH.4 | 31. SingleFlash 60 ... ALT | 54. TripleFlash 75 ... SIM |
| 9. DoubleFlash 75 ... PH.1 | 32. SingleFlash 60 ... SIM | 55. TripleFlash 120 ... ALT |
| 10. DoubleFlash 75 ... PH.2 | 33. SingleFlash 90 ... ALT | 56. TripleFlash 120 ... SIM |
| 11. DoubleFlash 75 ... PH.3 | 34. SingleFlash 90 ... SIM | 57. SigAlert Cal.™ ... ALT |
| 12. DoubleFlash 75 ... PH.4 | 35. SingleFlash 120 ... ALT | 58. SigAlert Cal. ... SIM |
| 13. SingleFlash 75 ... PH.1 | 36. SingleFlash 120 ... SIM | 59. Action 1 ... ALT |
| 14. SingleFlash 75 ... PH.2 | 37. SingleFlash 300 ... ALT | 60. Action 1 ... SIM |
| 15. SingleFlash 75 ... PH.3 | 38. SingleFlash 300 ... SIM | 61. Action 2 ... ALT |
| 16. SingleFlash 75 ... PH.4 | 39. DoubleFlash 150 ... ALT | 62. Action 2 ... SIM |
| 17. ComAlert™ 75 ... PH.1 | 40. DoubleFlash 150 ... SIM | 63. CalScan™ ... Alt/Sim |
| 18. ComAlert 75 ... PH.2 | 41. ComAlert™ 150 ... ALT | 64. ActionScan™ ... Alt/Sim |
| 19. ComAlert 75 ... PH.3 | 42. ComAlert 150 ... SIM | 65. SteadyFlash 60 |
| 20. ComAlert 75 ... PH.4 | 43. ActionFlash™ 50 ... ALT | 66. SteadyFlash 75 |
| 21. LongBurst™ 75 ... PH.1 | 44. ActionFlash 50 ... SIM | 67. SteadyFlash 90 |
| 22. LongBurst 75 ... PH.2 | 45. ActionFlash 150 ... ALT | 68. SteadyFlash 120 |
| 23. LongBurst 75 ... PH.3 | 46. ActionFlash 150 ... SIM | 69. Steady & Steady |

NOTE: BOLD = CA Title XIII Compliant Pattern *Italic* = SYNC Pattern

Warnings to Installers

Whelen's emergency vehicle warning devices must be properly mounted and wired in order to be effective and safe. Read and follow all of Whelen's written instructions when installing or using this device. Emergency vehicles are often operated under high speed stressful conditions which must be accounted for when installing all emergency warning devices. Controls should be placed within convenient reach of the operator so that he can operate the system without taking his eyes off the roadway. Emergency warning devices can require high electrical voltages and/or currents. Properly protect and use caution around live electrical connections. Grounding or shorting of electrical connections can cause high current arcing, which can cause personal injury and/or vehicle damage, including fire. Many electronic devices used in emergency vehicles can create or be affected by electromagnetic interference. Therefore, after installation of any electronic device it is necessary to test all electronic equipment simultaneously to insure that they operate free of interference from other components within the vehicle. Never power emergency warning equipment from the same circuit or share the same grounding circuit with radio communication equipment. All devices should be mounted in accordance with the manufacturer's instructions and securely fastened to vehicle elements of sufficient strength to withstand the forces applied to the device. Driver and/or passenger air bags (SRS) will affect the way equipment should be mounted. This device should be mounted by permanent installation and within the zones specified by the vehicle manufacturer, if any. Any device mounted in the deployment area of an air bag will damage or reduce the effectiveness of the air bag and may damage or dislodge the device. Installer must be sure that this device, its mounting hardware and electrical supply wiring does not interfere with the air bag or the SRS wiring or sensors. Mounting the unit inside the vehicle by a method other than permanent installation is not recommended as unit may become dislodged during swerving; sudden braking or collision. Failure to follow instructions can result in personal injury. Whelen assumes no liability for any loss resulting from the use of this warning device. **PROPER INSTALLATION COMBINED WITH OPERATOR TRAINING IN THE PROPER USE OF EMERGENCY WARNING DEVICES IS ESSENTIAL TO INSURE THE SAFETY OF EMERGENCY PERSONNEL AND THE PUBLIC.**

Warnings to Users

Whelen's emergency vehicle warning devices are intended to alert other operators and pedestrians to the presence and operation of emergency vehicles and personnel. However, the use of this or any other Whelen emergency warning device does not guarantee that you will have the right-of-way or that other drivers and pedestrians will properly heed an emergency warning signal. Never assume you have the right-of-way. It is your responsibility to proceed safely before entering an intersection, driving against traffic, responding at a high rate of speed, or walking on or around traffic lanes. Emergency vehicle warning devices should be tested on a daily basis to ensure that they operate properly. When in actual use, the operator must ensure that both visual and audible warnings are not blocked by vehicle components (i.e.: open trunks or compartment doors), people, vehicles, or other obstructions. It is the user's responsibility to understand and obey all laws regarding emergency warning devices. The user should be familiar with all applicable laws and regulations prior to the use of any emergency vehicle warning device. Whelen's audible warning devices are designed to project sound in a forward direction away from the vehicle occupants. However, because sustained periodic exposure to loud sounds can cause hearing loss, all audible warning devices should be installed and operated in accordance with the standards established by the National Fire Protection Association.