

None	Bracket Assy.		Kit No.	700371	
711332	Bracket Bolt Pkg. (Inc. items 12, 14, 15)		Make	Chevy	
None	Pulley Bolt Pkg.		Engine	8.1L	
711334	Idler Bolt Pkg. (Inc. items 6, 16-18)		Fuel	Gas	
None	Fan Spacer Bolt Pkg.		Year	2000-	
			Equipment	A/C	
			Revised	B	2-19-01

ITEM	PART #	DESCRIPTION			
1.	710096	Engine mount bracket	11.	-----	-----
2.	710936	Plate/pump mount	12.	110465	3/8-16 x 1 1/4 skt head bolt
3.	-----	-----	13.	-----	-----
4.	-----	-----	14.	110488	M10 x 45 x 1.5 Bolt
5.	-----	-----	15.	110479	M10 x 30 x 1.5 Bolt
6.	711333	Idler bushing	16.	110225	M12 x 90 x 1.75 Bolt
7.	OEM	Idler pulley from OEM tensioner	17.	110180	M10 x 60 x 1.5 Bolt
8.	740335	Tensioner	18.	110676	3/8 Flat washer
9.	*	Pump (side port)	19.	110425	3/8-16 x 1 1/4 Bolt
10.	740144	Clutch	20.	740336	Belt/Micro-V

* See master list for pump part number.

Note: Due to the lack of a key between the crankshaft pulley and the crankshaft the use of 12 and 17 GPM pumps is restricted. The PSI limit on a 12 GPM pump is 1850 PSI. The limit for a 17 GPM pump is 1700 PSI. Using higher settings may result in premature failures and unwarrantable damages.

FIG. 1
BELT DIAGRAM

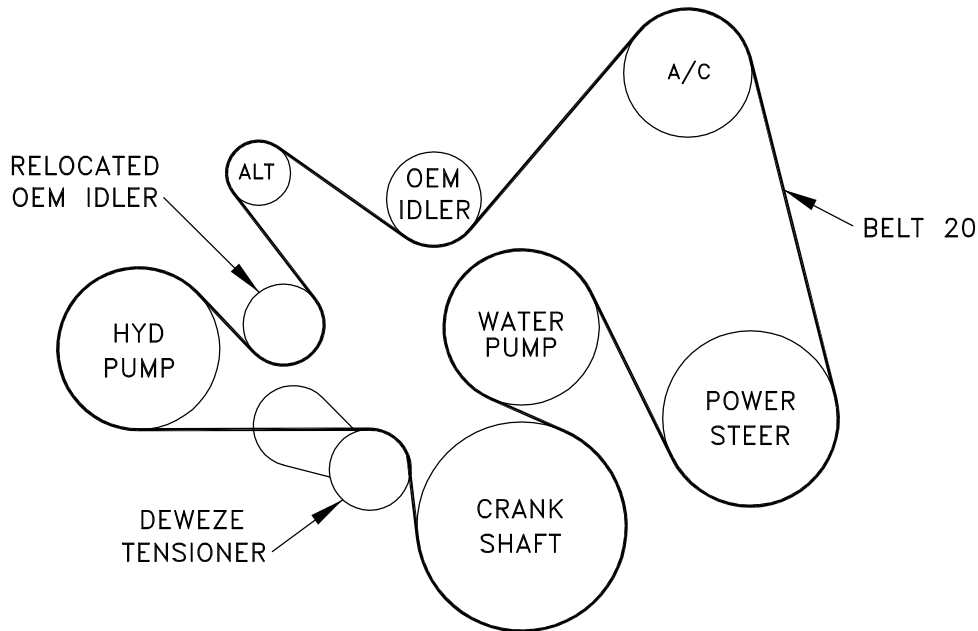

(A)(B)(C)... Denotes bolt holes in engine to locate corresponding holes in Pump Brkt.

FIG. 2A

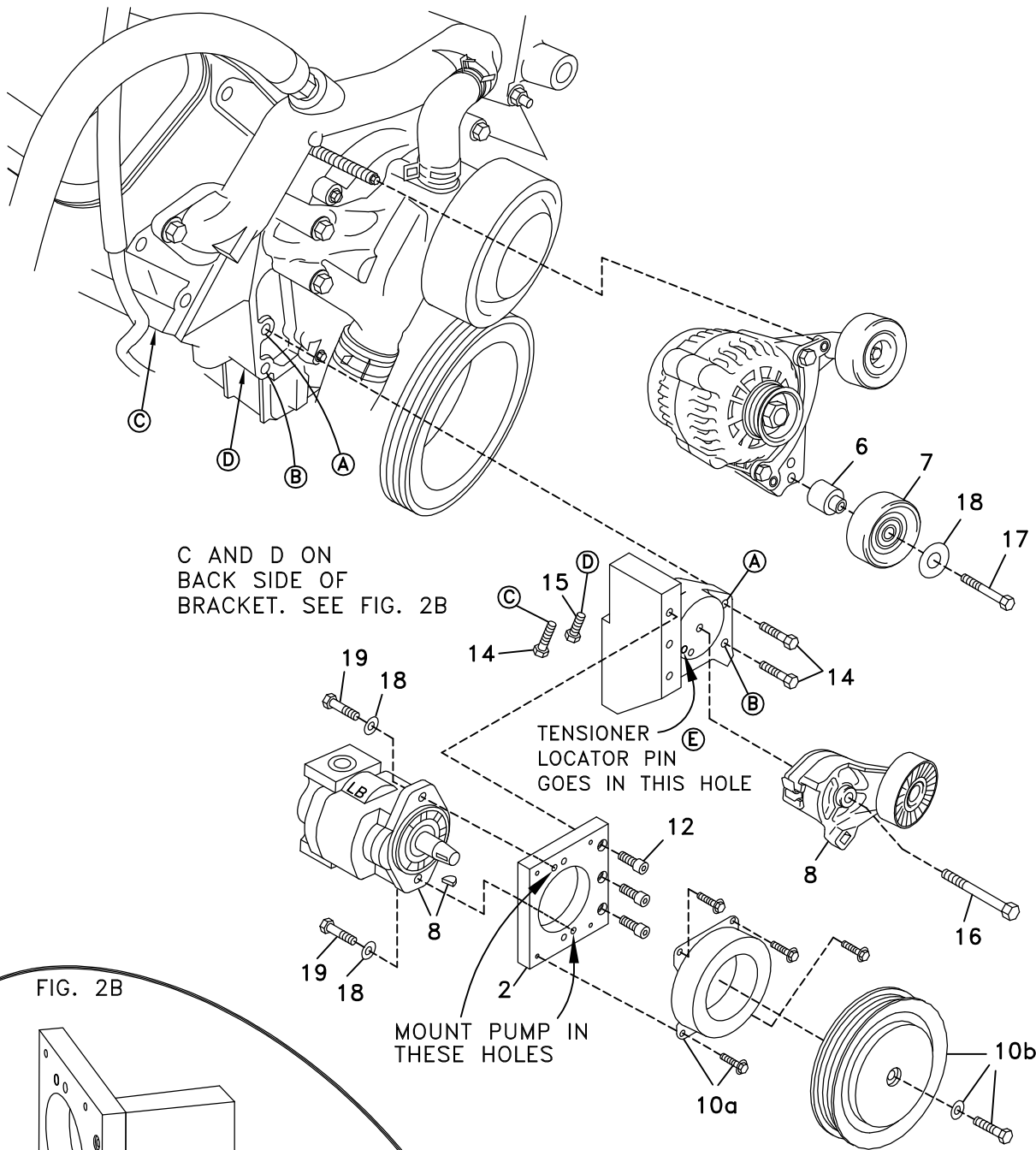

C AND D ON
BACK SIDE OF
BRACKET. SEE FIG. 2B

TENSIONER
LOCATOR PIN
GOES IN THIS HOLE

MOUNT PUMP IN
THESE HOLES

FIG. 2B

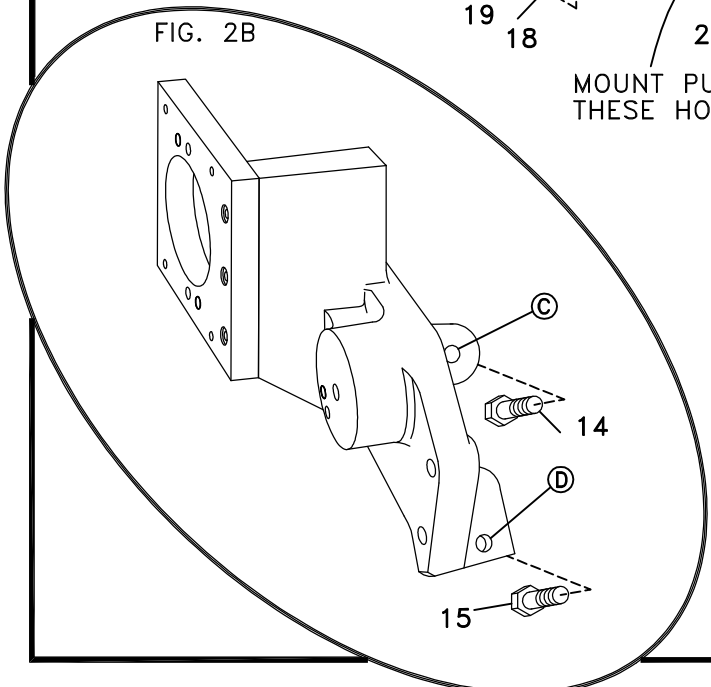

DewEze

Clutch Pump Kit
#700371
Chevrolet/
GMC 8.1L
With A/C
'A' mount
2000

INSTALLATION INSTRUCTIONS

NOTE: Due to the lack of a key between the crankshaft pulley and the crankshaft the use of 12 and 17 GPM pumps is restricted. The PSI limit on a 12 GPM pump is 1850 PSI. The limit for a 17 GPM pump is 1700 PSI. Using higher settings may result in premature failures and unwarrantable damages.

1. Disconnect the battery.
2. Remove the OEM serpentine belt. Remove the fan and shroud.
3. Remove the OEM tensioner from the alternator bracket. Remove the idler from the tensioner. Place this idler on the idler bushing (6), insert the M10 x 60 bolt (17) through a 3/8 flat washer (18), the idler pulley and the bushing and thread it into the alternator bracket where the tensioner originally was.
NOTE: The alternator and its mounting bracket do not need to be removed. It is moved out of the way in the drawing only to give a clearer view of the pump mounting bracket location.
4. Remove the ground cable from the engine at location D. Mount the assembled bracket to the engine at locations A and B with two M10 x 45 bolts (14). Thread another M10 x 45 bolt (14) up through the upper hole on the rear of the pump bracket at location C and into the engine. Insert the M10 x 30 bolt (15) through the ground cable and into the lower hole in the rear of the bracket at location D and into the engine.
5. Attach the DewEze tensioner (8) to the bracket with the M12 x 90 bolt (16). Be sure to place the locating boss on the back of the tensioner in the upper 5/16" hole at location E.
6. Mount the pump (8) to the pump plate (2) using two 3/8 x 1 1/4 bolts (19) and two 3/8 flat washers (18) into the two holes that are 20 degrees off vertical as shown in the detail drawing. Attach the hydraulic fittings to the pump. Place the pump plate with the pump onto the bracket with three 3/8 x 1 1/4 socket head bolts (12). Attach the clutch coil (10a) to the pump plate (2) with the four flange bolts included with the clutch. Attach the clutch pulley (10b) onto the pump shaft with the bolt and heavy washer included with the clutch.
7. Install the DewEze belt (20) as shown in the belt diagram.
8. Reconnect the battery. Run the engine to check alignment and clearance.
9. Install fan and fan shroud. Run engine again with everything in place to check alignment and clearance.