

51 Winthrop Road
 Chester, Connecticut 06412-0684
 Phone: (860) 526-9504
 Sales Email: autosale@whelen.com
 Canadian Sales: canadiansales@whelen.com
 Customer Service: custserv@whelen.com

Safety First: This document provides all the necessary information to allow your Whelen product to be properly and safely installed. Before beginning the installation and/or operation of your new product, the installation technician and operator must read this manual completely. Important information is contained herein that could prevent serious injury or damage.

- Proper installation of this product requires the installer to have a good understanding of automotive electronics, systems and procedures.
- Whelen Engineering requires the use of waterproof butt splices and/or connectors if that connector could be exposed to moisture.
- Any holes, either created or utilized by this product, should be made both air- and watertight using a sealant recommended by your vehicle manufacturer.
- Failure to use specified installation parts and/or hardware will void the product warranty!
- If mounting this product requires drilling holes, the installer **MUST** be sure that no vehicle components or other vital parts could be damaged by the drilling process. Check both sides of the mounting surface before drilling begins. Also de-burr any holes and remove any metal shards or remnants. Install grommets into all wire passage holes.
- Do not install this product or route any wires in the deployment area of your air bag. Equipment mounted or located in the air bag deployment area will damage or reduce the effectiveness of the air bag, or become a projectile that could cause serious personal injury or death. Refer to your vehicle owner's manual for the air bag deployment area. The User/Installer assumes full responsibility to determine proper mounting location, based on providing ultimate safety to all passengers inside the vehicle.
- For this product to operate at optimum efficiency, a good electrical connection to chassis ground must be made. The recommended procedure requires the product ground wire to be connected directly to the **NEGATIVE (-)** battery post.
- If this product uses a remote device to activate or control this product, make sure that this control is located in an area that allows both the vehicle and the control to be operated safely in any driving condition.
- Do not attempt to activate or control this device in a hazardous driving situation.
- This product contains either strobe light(s), halogen light(s), high-intensity LEDs or a combination of these lights. Do not stare directly into these lights. Momentary blindness and/or eye damage could result.
- Use only soap and water to clean the outer lens. Use of other chemicals could result in premature lens cracking (crazing) and discoloration. Lenses in this condition have significantly reduced effectiveness and should be replaced immediately. Inspect and operate this product regularly to confirm its proper operation and mounting condition. Do not use a pressure washer to clean this product.
- **WARNING!** All customer supplied wires that connect to the positive (+) terminal of the battery must be sized to supply at least 125% of the maximum operating current and **FUSED** "at the battery" to carry that load. **DO NOT USE CIRCUIT BREAKERS WITH THIS PRODUCT!**
- **FAILURE TO FOLLOW THESE PRECAUTIONS AND INSTRUCTIONS COULD RESULT IN DAMAGE TO THE PRODUCT OR VEHICLE AND/OR SERIOUS INJURY TO YOU AND YOUR PASSENGERS!**

Installation:

WARNING! "External Flasher" models require an electronic flasher. Allowing the LED to steady burn will damage the lighthead and void the warranty.

External flasher models draw less current than a normal automotive bulb. If your flasher does not operate properly, replace your flasher with a Whelen 3TERM flasher.

Note: Make sure lighthead will not interfere with existing equipment or any items on the opposite side of the mounting surface.

1. Using the dimensions shown, drill the four, 1/4" diameter mounting holes and a 1" inch wire hole into the mounting surface. Check measurements before drilling.
2. Install the 4, supplied plastic grommets into the mounting holes. Install a rubber grommet (customer supplied) into the wire hole.
3. Using appropriately sized wires (min. 18 AWG), extend the wires to their connections. Fuse the positive connections at 3 amps and test operation before mounting.
4. Mount the lighthead to the vehicle using the four #8 x 1-1/2" sheet metal screws.

On-Board Flasher Models:

Scan-Lock[™] (WHT-VIO): This feature allows the user to select from several available flash patterns.

TO CYCLE THROUGH ALL PATTERNS: Apply positive voltage to the WHITE-VIOLET wire for less than 1 second and release. Apply positive voltage to the WHITE-VIOLET wire for more than 1 second and release to cycle backward.

TO SET A PATTERN AS DEFAULT: Allow the desired pattern to run for more than 5 seconds. The lighthead will now display this pattern when active.

TO RESET TO THE FACTORY DEFAULT PATTERN: Turn off power, apply positive voltage to the WHITE-VIOLET wire, then turn power on.

Available Flash Patterns: SignalAlert[™] 75 / SignalAlert 150 / SingleFlash 375 / SingleFlash 150 / SingleFlash 75 / DoubleFlash 150 / DoubleFlash 75 / CometFlash[®]75 / ActionFlash[™] / ModuFlash[™] / ComAlert[™] / ActionScan[™] / SignalAlert Steady / Steady (Brake)

Hi/Lo Intensity (VIO): This feature allows the user to step the unit down to low power operation for nighttime use.

Apply +VBAT to the VIOLET wire to put the lighthead into low power. Remove the +VBAT from the VIOLET wire for high power operation.

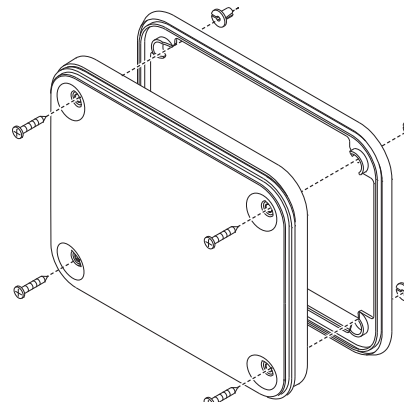
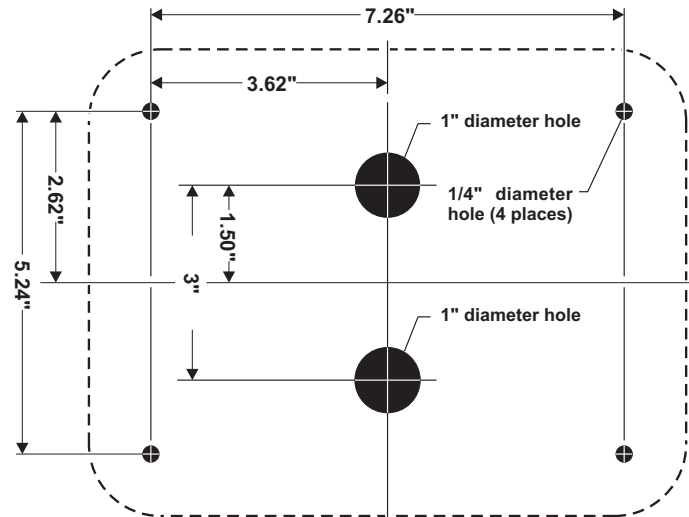

WIRE FUNCTIONS - LO-POWER 12V

LED COLOR - Power
 BLACK - Ground
 VIOLET - Hi/Low Power
 WHITE/VIOLET - Scan-Lock[™]

WIRE FUNCTIONS - STEADY 12V

LED COLOR - Power
 BLACK - Ground

WIRE FUNCTIONS - LO-POWER 24V

LED COLOR - Power
 BLACK/WHITE - Ground
 VIOLET - Hi/Low Power
 WHITE/VIOLET - Scan-Lock[™]

WIRE FUNCTIONS - STEADY 24V

LED COLOR - Power
 BLACK/WHITE - Ground

WIRE FUNCTIONS - EXTERNAL FLASHER 12V

SOLID LED COLOR WIRE
 Power (Upper Side 1)
 BLACK - GROUND (Upper Side 1)

WHITE/LED COLOR TRACE WIRE

Power (Upper Side 2)
 WHITE/BLACK
 GROUND (Upper Side 2)

SOLID LED COLOR WIRE

Power (Lower Side 1)
 BLACK - GROUND
 (Lower Side 1)

WHITE/LED COLOR TRACE WIRE

Power (Lower Side 2)
 WHITE/BLACK - GROUND
 (Lower Side 2)

Warnings to Installers

Whelen's emergency vehicle warning devices must be properly mounted and wired in order to be effective and safe. Read and follow all of Whelen's written instructions when installing or using this device. Emergency vehicles are often operated under high speed stressful conditions which must be accounted for when installing all emergency warning devices. Controls should be placed within convenient reach of the operator so that he can operate the system without taking his eyes off the roadway. Emergency warning devices can require high electrical voltages and/or currents. Properly protect and use caution around live electrical connections. Grounding or shorting of electrical connections can cause high current arcing, which can cause personal injury and/or vehicle damage, including fire. Many electronic devices used in emergency vehicles can create or be affected by electromagnetic interference. Therefore, after installation of any electronic device it is necessary to test all electronic equipment simultaneously to insure that they operate free of interference from other components within the vehicle. Never power emergency warning equipment from the same circuit or share the same grounding circuit with radio communication equipment. All devices should be mounted in accordance with the manufacturer's instructions and securely fastened to vehicle elements of sufficient strength to withstand the forces applied to the device. Driver and/or passenger air bags (SRS) will affect the way equipment should be mounted. This device should be mounted by permanent installation and within the zones specified by the vehicle manufacturer, if any. Any device mounted in the deployment area of an air bag will damage or reduce the effectiveness of the air bag and may damage or dislodge the device. Installer must be sure that this device, its mounting hardware and electrical supply wiring does not interfere with the air bag or the SRS wiring or sensors. Mounting the unit inside the vehicle by a method other than permanent installation is not recommended as unit may become dislodged during swerving; sudden braking or collision. Failure to follow instructions can result in personal injury. Whelen assumes no liability for any loss resulting from the use of this warning device. **PROPER INSTALLATION COMBINED WITH OPERATOR TRAINING IN THE PROPER USE OF EMERGENCY WARNING DEVICES IS ESSENTIAL TO INSURE THE SAFETY OF EMERGENCY PERSONNEL AND THE PUBLIC.**

Warnings to Users

Whelen's emergency vehicle warning devices are intended to alert other operators and pedestrians to the presence and operation of emergency vehicles and personnel. However, the use of this or any other Whelen emergency warning device does not guarantee that you will have the right-of-way or that other drivers and pedestrians will properly heed an emergency warning signal. Never assume you have the right-of-way. It is your responsibility to proceed safely before entering an intersection, driving against traffic, responding at a high rate of speed, or walking on or around traffic lanes. Emergency vehicle warning devices should be tested on a daily basis to ensure that they operate properly. When in actual use, the operator must ensure that both visual and audible warnings are not blocked by vehicle components (i.e.: open trunks or compartment doors), people, vehicles, or other obstructions. It is the user's responsibility to understand and obey all laws regarding emergency warning devices. The user should be familiar with all applicable laws and regulations prior to the use of any emergency vehicle warning device. Whelen's audible warning devices are designed to project sound in a forward direction away from the vehicle occupants. However, because sustained periodic exposure to loud sounds can cause hearing loss, all audible warning devices should be installed and operated in accordance with the standards established by the National Fire Protection Association.