



### Technical Description

InPower's ABS Series of Auxiliary Battery Switches are the ideal solution for charging and isolating an auxiliary battery from a vehicle's chassis battery and alternator. InPower's ABS Series is designed to replace outmoded battery isolators and unreliable mechanical battery separators.

The ABS uses InPower's proven patented solid-state contactor technology, incorporating sophisticated microprocessor algorithms to monitor over-current and under-voltage sensing.

The auxiliary battery is charged from the chassis battery and alternator, while the chassis battery is protected from auxiliary battery load discharge. Since the ABS is bidirectional, a charging device (such as a battery charger or genset) connected to the auxiliary battery can also supply charging current to the chassis battery when needed. A "boost start" feature allows both the auxiliary and chassis batteries to supply current to aid engine starting.

InPower's ABS Auxiliary Battery Switches are available in 100, 150, 175 and 200 amp models. To properly size your ABS, first determine how much extra current is available from the chassis alternator. This is the maximum alternator output current less the minimum chassis load current. The difference is the maximum available auxiliary charging current. Select an ABS model with a capacity greater than this current.

- *Superb Auxiliary Battery Isolation*
- *Bidirectional Charging*
- *Boost start the vehicle from the auxiliary battery if the chassis battery voltage is low*
- *Solid state - no moving parts*
- *Extremely efficient - No need for a massive heat sink*
- *Over-current protection*

### System Diagram

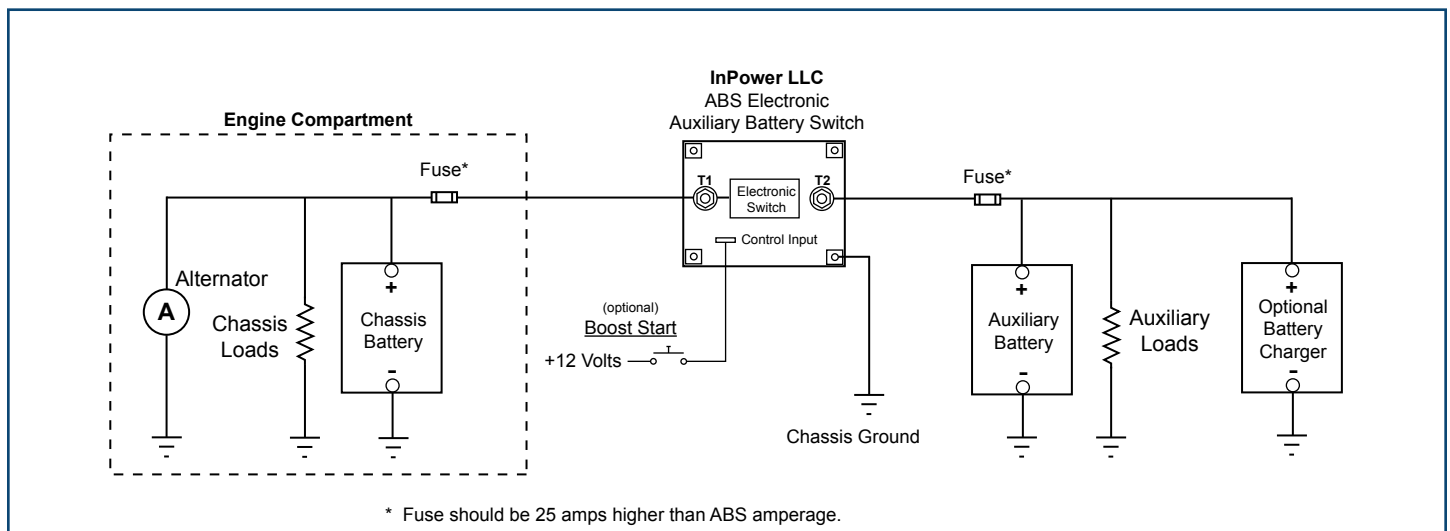

## Specifications

Maximum Current Rating:	ABS-100	ABS-150	ABS-175	ABS-200
	100 Amps	150 Amps	175 Amps	200 Amps
Logic Power Current:	5 milliamps			
Operating Voltage Range:	+3.0 to +18.0 Volts			
Over Current Trip:	100% to 110% for 500 Milliseconds			
Weight:	0.60 lbs			
Dimensions:	4.15 inches W x 4.15 inches L x 1.27 inches H			
Power Terminals:	3/8 - 16 stainless steel, with stainless steel locking nuts			
Ground Connection:	Ground pad at each of the four mounting holes			
Power Terminal Torque:	10 to 15 foot pounds			

## Ordering Guide

Model	Description
ABS-100	Auxiliary Battery Switch, 100 amps
ABS-150	Auxiliary Battery Switch, 150 amps
ABS-175	Auxiliary Battery Switch, 175 amps
ABS-200	Auxiliary Battery Switch, 200 amps
TB28-2	Terminal Boot for 8 - 2 AWG cable
TB28-3	Terminal Boot for 2 - 2/0 AWG cable

## Mechanical Drawing

