

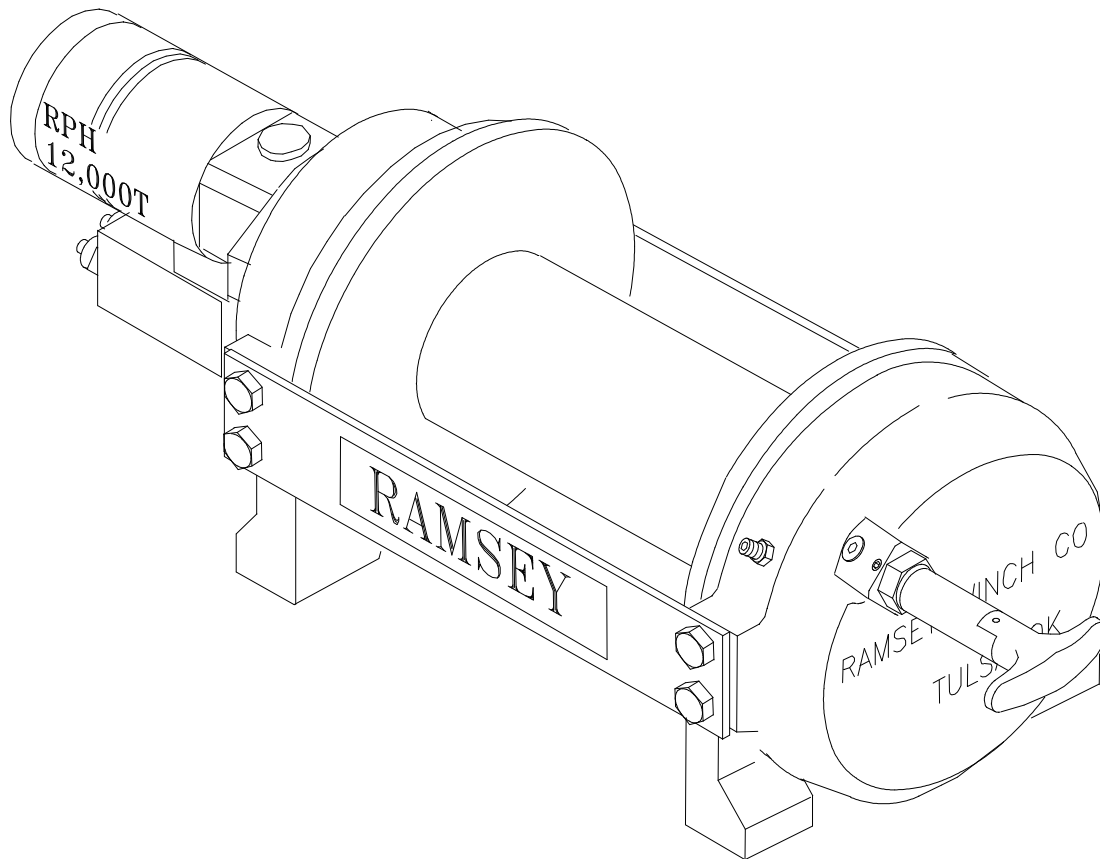

OPERATING, SERVICE AND MAINTENANCE MANUAL



MODEL RPH 12,000T PLANETARY WINCH

Intended Purpose: Vehicle Recovery and Pulling of Loads



CAUTION: READ AND UNDERSTAND THIS MANUAL BEFORE INSTALLATION AND OPERATION OF WINCH. SEE WARNINGS!

TABLE OF CONTENTS

INTRODUCTIONS.....	1
WARRANTY INFORMATION.....	1
SPECIFICATIONS.....	1
WARNINGS.	1
WINCH MOUNTING.....	2
CABLE INSTALLATION.....	3
HYDRAULIC SYSTEM REQUIREMENTS.....	4
PERFORMANCE CHARTS.....	4
OPERATIONS.....	5
MANUAL CLUTCH SHIFTER.....	5
MAINTENANCE.....	5
TROUBLE SHOOTING GUIDE.....	6
INSTRUCTIONS FOR OVERHAUL.....	7-12
DIMENSIONAL DRAWINGS	
RPH 12,000T WITH MANUAL CLUTCH SHIFTER.....	13
RPH 12,000T WITH AIR CYLINDER CLUTCH SHIFTER.....	14
PARTS LIST AND PARTS DRAWINGS	
RPH 12,000T WITH MANUAL CLUTCH SHIFTER.....	16-17
RPH 12,000T WITH AIR CYLINDER CLUTCH SHIFTER.....	18-19
RPH 12,000T WITH BLOCKED CLUTCH.....	20-21
LIMITED WARRANTY.....	22

RAMSEY HYDRAULIC PLANETARY WINCH MODEL RPH 12,000T

PLEASE READ THIS MANUAL CAREFULLY

This manual contains useful ideas for obtaining the most efficient operation from your Ramsey Winch, and safety procedures one needs to know before operating a Ramsey Winch. Do not operate this winch until you have carefully read and understand the "WARNING" and "OPERATION" sections of this manual.

WARRANTY INFORMATION

Ramsey Winches are designed and built to exacting specifications. Great care and skill go into every winch we make. If the need should arise, warranty procedure is outlined on the back of your self-addressed postage paid warranty card. Please read and fill out the enclosed warranty card and send it to Ramsey Winch Company. If you have any problems with your winch, please follow instructions for prompt service on all warranty claims. Refer to back page for limited warranty.

SPECIFICATIONS*

Noise Level: 70 dB(A)

Rated Line Pull (lbs.).....		11,015			
(Kn.).....		49			
Gear Reduction.....		5.1:1			
Weight (without cable).....		110 lbs. (50 kgs.)			
LAYER OF CABLE		1	2	3	4
*Rated line pull per layer	Lbs. Kn.	11,015 49	9,230 41	7,950 35	5,540 25
Cable capacity	Ft. M.	24 7	52 16	85 26	122 37
Line speed (at 15 GPM)	FPM MPM	36 11	42 12,8	50 15,2	71 21,6
*These specifications are based on recommended 12 mm wire rope and a 24.0 Cu. In./Rev. motor.					

NOTE: The rated line pulls shown are for the winch only. Consult the wire rope manufacturer for wire rope ratings.

WARNINGS:

CLUTCH MUST BE FULLY ENGAGED BEFORE STARTING THE WINCH.

DO NOT DISENGAGE CLUTCH UNDER LOAD.

DO NOT LEAVE CLUTCH ENGAGED WHEN WINCH IS NOT IN USE.

STAY OUT FROM UNDER AND AWAY FROM RAISED LOADS.

STAND CLEAR OF CABLE WHILE PULLING. DO NOT TRY TO GUIDE CABLE.

DO NOT EXCEED MAXIMUM LINE PULL RATINGS SHOWN IN TABLE.

DO NOT USE WINCH TO LIFT, SUPPORT, OR OTHERWISE TRANSPORT PERSONNEL.

A MINIMUM OF 5 WRAPS OF CABLE AROUND THE DRUM BARREL IS NECESSARY TO HOLD THE LOAD. CABLE CLAMP (SETSCREW) IS NOT DESIGNED TO HOLD LOAD.

IN CAR CARRIER APPLICATIONS, AFTER PULLING VEHICLE ON CARRIER, BE SURE TO SECURE VEHICLE TO CARRIER BED. DO NOT MAINTAIN LOAD ON WINCH CABLE WHILE TRANSPORTING VEHICLE. DO NOT USE WINCH AS A TIE DOWN.

WHEN PULLING A HEAVY LOAD PLACE A BLANKET, JACKET, OR TARPAULIN OVER THE CABLE FIVE OR SIX FEET FROM THE HOOK.

AVOID CONDITIONS WHERE LOAD SHIFTS OR JERKS OCCUR, AS THEY MAY INDICATE A DANGEROUS SITUATION.

WINCH MOUNTING

ESSENTIAL MOUNTING INSTRUCTIONS TO MAINTAIN ALIGNMENT OF PLANETARY WINCH COMPONENTS

It is most important that this winch be mounted securely so that the three major sections (the motor end, the cable drum and the gear-housing end) are properly aligned. Excessive bushing wear and difficulty in freespooling are usually symptoms of misalignment.

In the as-installed condition, if the winch is mid mounted at least one tie plate must be attached to the mounting feet at the bottom of the winch to maintain alignment. **NOTE:** If the winch is foot mounted, at least one tie plate must remain mounted at mid point of winch to maintain alignment. It is always desirable to use both tie plates in the final installed configuration.

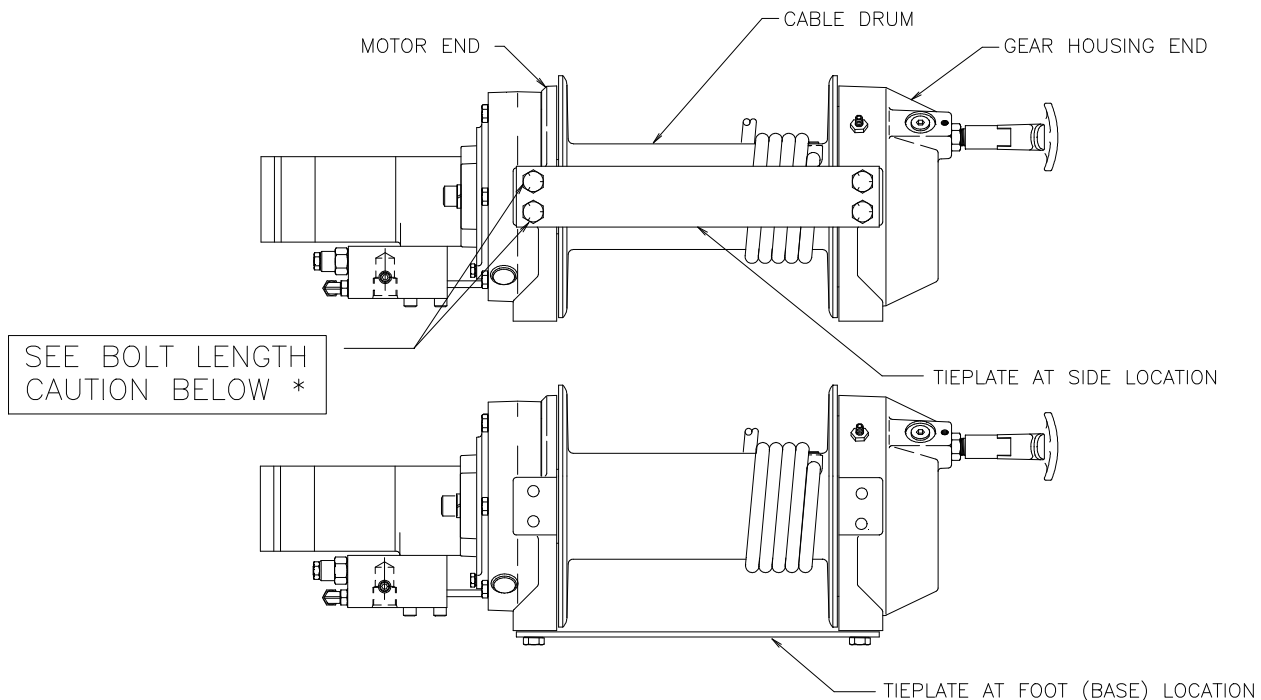

Angle Mounting Kit, #251006, is recommended for maximum ease in mounting the winch. The angle kit will allow the winch to be mounted in upright or midmount applications and will meet the criteria of serving as a solid and true mounting surface.

When mounting the winch with other than the recommended Ramsey Angle Kit, the mounting hole patterns described on page 14 must be used. The mounting surface must be flat within .015 inch and sufficiently stiff to resist flexing. If a steel plate is used for foot mounting it should be .750 inch thick. For this mounting application eight (8) 1/2-13NC x 1-1/2 Lg. Gr. 5 capscrews with lockwashers will be needed to mount winch. Capscrews should be torqued to 85 ft. lb. (115 Nm.).

NOTE: If angles or a steel plate are used in mounting winch, tie plates provided with winch are to be attached to the remaining mounting pads, whether they be side or foot.

***CAUTION:** If longer bolts (minimum Grade 5) are substituted to mount winch or to mount a roller guide at the side mount pads, bolt length must be such as to allow a maximum of .56 inch thread length engagement in the tapped holes in sides of each end bearing. Refer to page 13. Use of excessive length bolts will not allow tie plate to tighten down properly. Torque bolts to 55 ft. lbs. (75 Nm).

CABLE INSTALLATION

1. Unwind cable by rolling it out along the ground to prevent kinking. Securely wrap end of cable, opposite hook, with plastic or similar tape to prevent fraying.
2. Place taped end of cable into hole in cable drum, as shown below. Use 3/8-16NC x 1/2 lg. Hx. Soc. drive setscrew (part of 234171 drum assembly) to secure cable to drum.
3. Carefully run winch in the "reel-in" direction. Keeping tension on end of cable, spool all the cable onto the cable drum, taking care to form neatly wrapped layers.

After installing cable, check freespool operation. Disengage clutch and pull on cable at a walking speed. If cable "birdnests", loosen jam nut (item #21) and turn nylon screw (item #19) clockwise to increase drag on drum. If cable pull is excessive loosen nylon setscrew by turning counterclockwise. Tighten jam nut when proper setting is obtained. **CAUTION: Over-tightening of jam nut may strip nylon setscrew.**

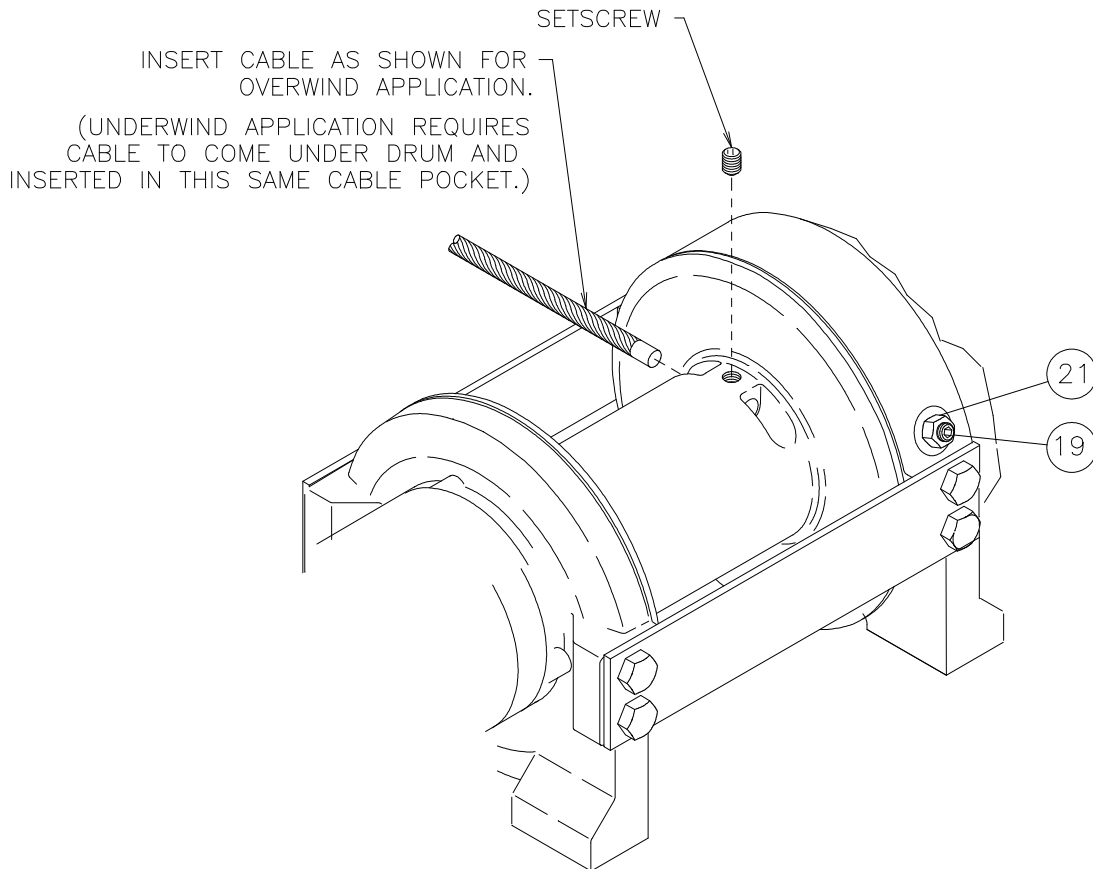

HYDRAULIC SYSTEM REQUIREMENTS

Refer to the performance charts below to properly match your hydraulic system to the winch performance. The charts consist of: (1) first layer line pull (LB) vs. working pressure (PSI), (2) first layer line speed (FPM) vs. flow (GPM), and (3) relief valve setting (PSI) vs. flow (GPM). A motor spool directional control valve is required.

SYSTEM REQUIREMENTS:
2500 PSI RELIEF VALVE SETTING*
15 GPM FLOW RATE**
10 MICRON NOMINAL FILTRATION

INSTALLER MUST DETERMINE TYPE OF EMERGENCY STOP REQUIRED. A MANUAL CONTROL VALVE ALSO SERVES AS AN EMERGENCY STOP VALVE. AN EMERGENCY STOP VALVE MAY BE REQUIRED WITH OTHER TYPES OF CONTROL VALVES.

***CAUTION: DO NOT EXCEED 20 G.P.M. IF EXCEEDED, MOTOR AND WINCH MAY BE DAMAGED**

TYPICAL LAYOUT

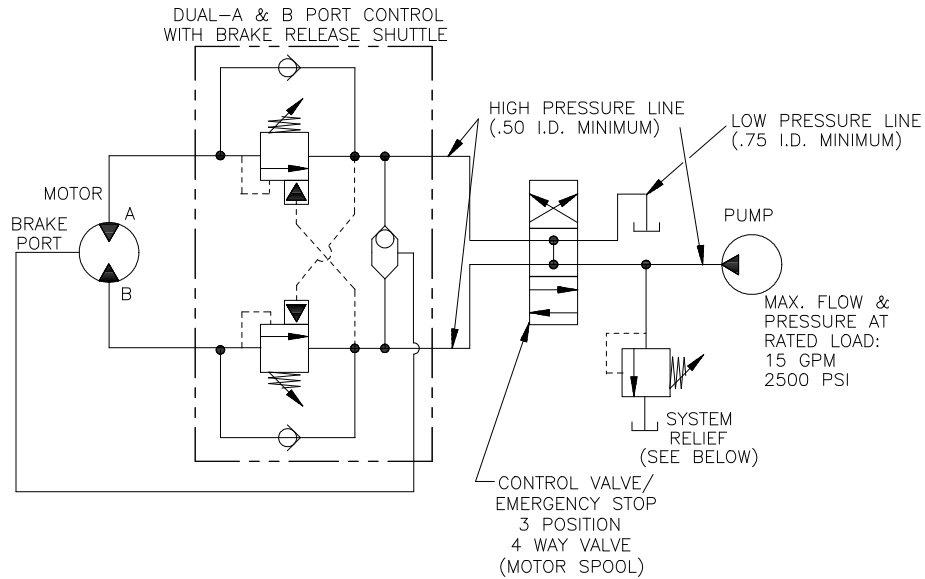

PERFORMANCE CHARTS

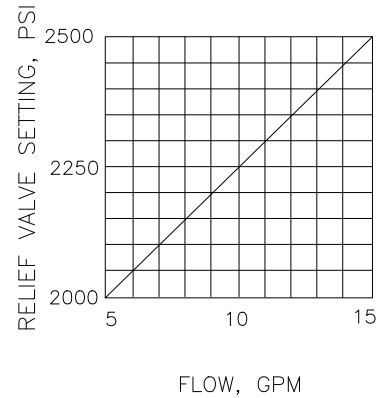
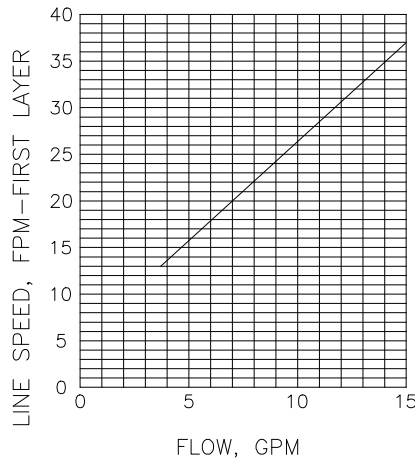
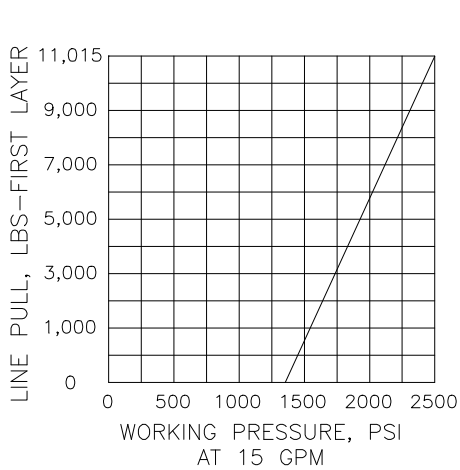

PERFORMANCE WITH 24.0 CU. IN. HYDRAULIC MOTOR

OPERATION

The best way to get acquainted with how your winch operates is to make test runs before you actually use it. Plan your test in advance. Remember, you hear your winch, as well as see it operate. Get to recognize the sounds of a light steady pull, a heavy pull, and sounds caused by load jerking or shifting. Avoid conditions where load shifts or jerks occur, as they may indicate a dangerous situation.

The uneven spooling of cable, while pulling a load, is not a problem, unless there is a cable pileup on one end of drum. If this happens, reverse the winch to relieve the load and move your anchor point further to the center of the vehicle. After the job is done you can unspool and rewind for a neat lay of the cable.

When pulling a heavy load place a blanket, jacket or tarpaulin over the cable about five or six feet behind the hook. In the event of a broken cable, this will slow the snap back of the cable and could prevent serious injury.

The winch clutch allows rapid unspooling of the cable from the cable drum for hooking onto the load. The clutch is operated by the clutch shifter lever or air shifter.

WARNING: DO NOT DISENGAGE CLUTCH UNDER LOAD.

MANUAL CLUTCH SHIFTER (Refer to page 13)

TO DISENGAGE CLUTCH: Run the winch in the reverse (reel out) direction until load is off the cable. Pull handle out and rotate 90°. With handle in the "DISENGAGED" position, cable may now be free-spoiled from drum.

TO ENGAGE CLUTCH: Pull handle out, rotate 90° and release handle. Run the winch in reverse until the clutch handle snaps fully into the "ENGAGED" position. **DO NOT** attempt to pull a load unless the handle is fully at the "ENGAGED" position.

AIR CYLINDER CLUTCH SHIFTER (Refer to page 14)

TO DISENGAGE CLUTCH: Run the winch in the reverse (reel out) direction until load is off the cable. Apply air pressure to the .125-27 NPT port: 80 PSI (min.) 150 PSI (max.). **CAUTION: Pressure must not exceed 150 PSI.**

TO ENGAGE CLUTCH: Remove air pressure from the cylinder (a return spring engages the plunger). Run winch in reverse until the clutch engagement indicator light (green light) is lit. **DO NOT** attempt to pull a load unless the green light is lit. To connect light to the vehicle electrical system refer to the Electrical Schematic on page 14.

MAINTENANCE

1. Inspect the cable for damage and lubricate frequently. If the cable becomes frayed with broken strands, replace immediately.
2. Check that the clutch is fully engaging. See OPERATION instructions, above, for the appropriate clutch shifter. **FOR MANUAL CLUTCH ONLY:** Monthly disengage clutch, put several drops of oil on the shaft and work clutch IN and OUT several times to lubricate inside of clutch cylinder.
3. Check to see that drum cable does not overrun (birdnest) when freespooling. Refer to page 3.
4. Replace drum bushings and seals when seals begin to seep grease. Refer to OVERHAUL INSTRUCTIONS, page 7. Add additional lubricant, Mobilith SHC 007, to gears if required.

TROUBLE SHOOTING GUIDE

CONDITIONS	POSSIBLE CAUSE	CORRECTION / ACTION
DRUM WILL NOT ROTATE AT NO LOAD	Brake damaged.	Inspect and replace brake.
	Gears damaged.	Inspect and replace damaged gears.
	Brake not releasing	See section below.
DRUM WILL NOT ROTATE UNDER LOAD	Load greater than rated capacity of winch.	Refer to Specifications pg.1 for line pull rating.
	Low hydraulic system pressure.	Check pressure. Refer to HYDRAULIC SYSTEMS performance charts pg. 4.
WINCH RUNS TOO SLOW	Low hydraulic system flow rate.	Check flow rate. Refer to HYDRAULIC SYSTEMS flow chart page 4.
	Motor worn out.	Replace motor.
DRUM WILL NOT FREESPOOL	Clutch not disengaged.	Check clutch shifter. Refer to page 5. Check ADJUSTMENT. Refer to page 10.
BRAKE WILL NOT RELEASE	Brake damaged.	Inspect and replace. Refer to page 8 & 11 for overhaul.
CABLE BIRDNESTS WHEN CLUTCH IS DISENGAGED	Drag screw improperly adjusted.	Adjust nylon drag screw. Refer to pg. 3.
EXCESSIVE NOISE	Hydraulic system flow too high	Check flow rate. Refer to HYDRAULIC SYSTEMS flow chart pg. 4.
DRUM CHATTERS, in "REEL IN" direction	Low hydraulic system flow.	Check flow rate. Refer to HYDRAULIC SYSTEMS flow chart pg. 4.
	Low hydraulic system relief pressure setting.	Check relief valve setting. Refer to HYDRAULIC SYSTEMS pg. 4.
OIL SEEPAGE FROM BREATHER VENT OF BRAKE HOUSING	Brake piston not sealing properly.	Replace o-ring and back up rings on brake piston. Refer to page 8 & 11.
GREASE SEEPAGE FROM JOINTS IN MOTOR	Grease applied to seals during assembly by the motor manufacturer.	NONE. Normal condition during the first few times the winch is operated.

INSTRUCTIONS FOR OVERHAUL OF RAMSEY WINCH

MODEL RPH 12,000T

DISASSEMBLY

Take note of mounting configuration for proper mounting of parts during re-assembly. Disconnect tube (item #44) from elbows (item #24) on bottom of brake (item #6) and valve (item #45). Remove motor (item #31) from brake housing (item #6) by unscrewing capscrews (item #15). Tap motor lightly to disengage. Replace all gaskets, o-rings and seals with new ones during re-assembly.

Remove coupling (item #23) from brake housing. Examine coupling for signs of wear, replace if necessary. If necessary, remove valve (item #45) from motor by removing capscrews (item #19). If valve is removed make sure two square cross section o-rings remain seated in their counter bores in valve.

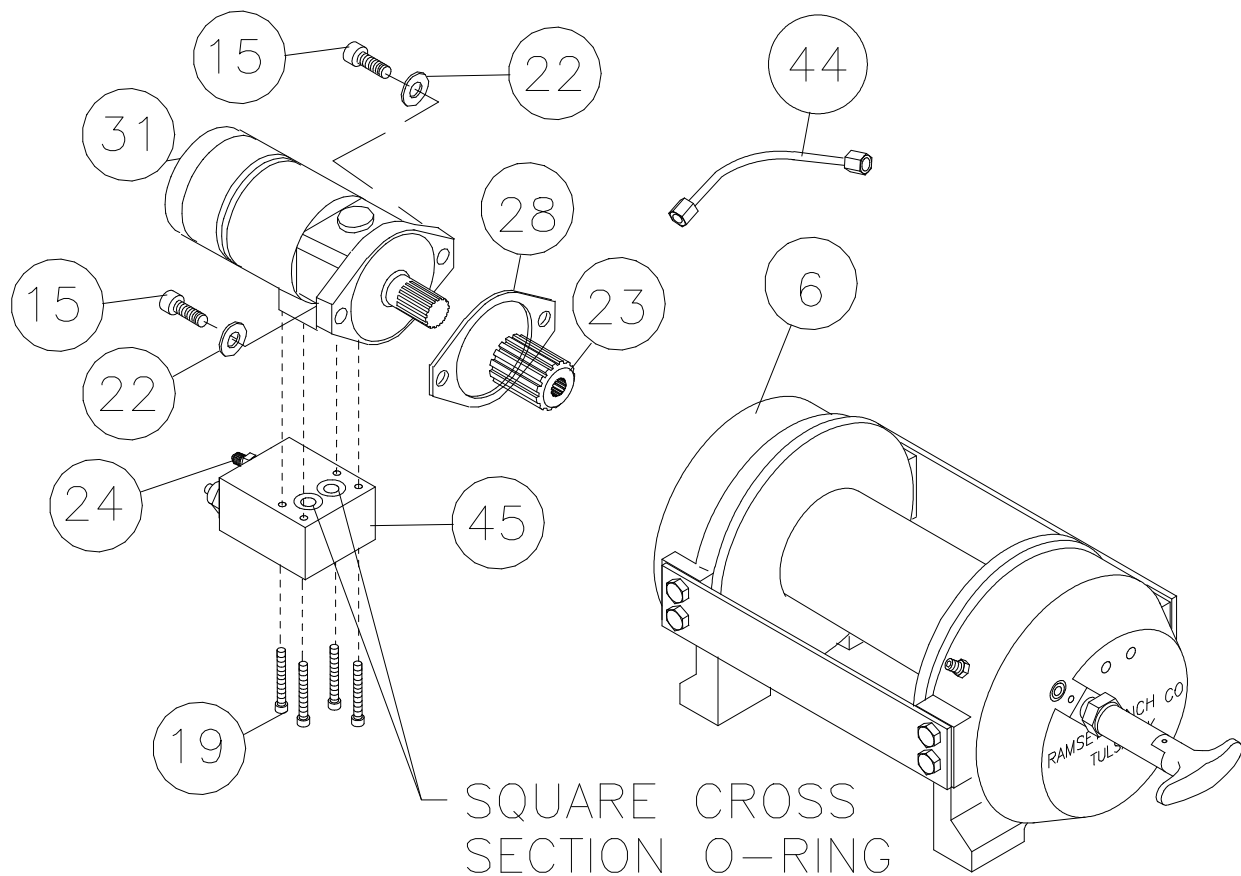

Remove brake housing (item #6) from end bearing (item #4) by unscrewing (6) capscrews (item #14) in a criss-cross pattern (2 turns each) until all capscrews are removed from brake housing. Remove brake parts from brake housing. Examine brake discs (item #26) for signs of wear, and replace if necessary. Examine o-rings (items #34 & #35) and backup rings (items #36 & #37) for signs of wear. Remove o-rings and backup rings from grooves in brake piston (item #3).

Remove and examine springs (items #42 & #43) for damage, replace if necessary.

Examine fitting (item #30) to assure that fittings are in proper working condition, replace if necessary.

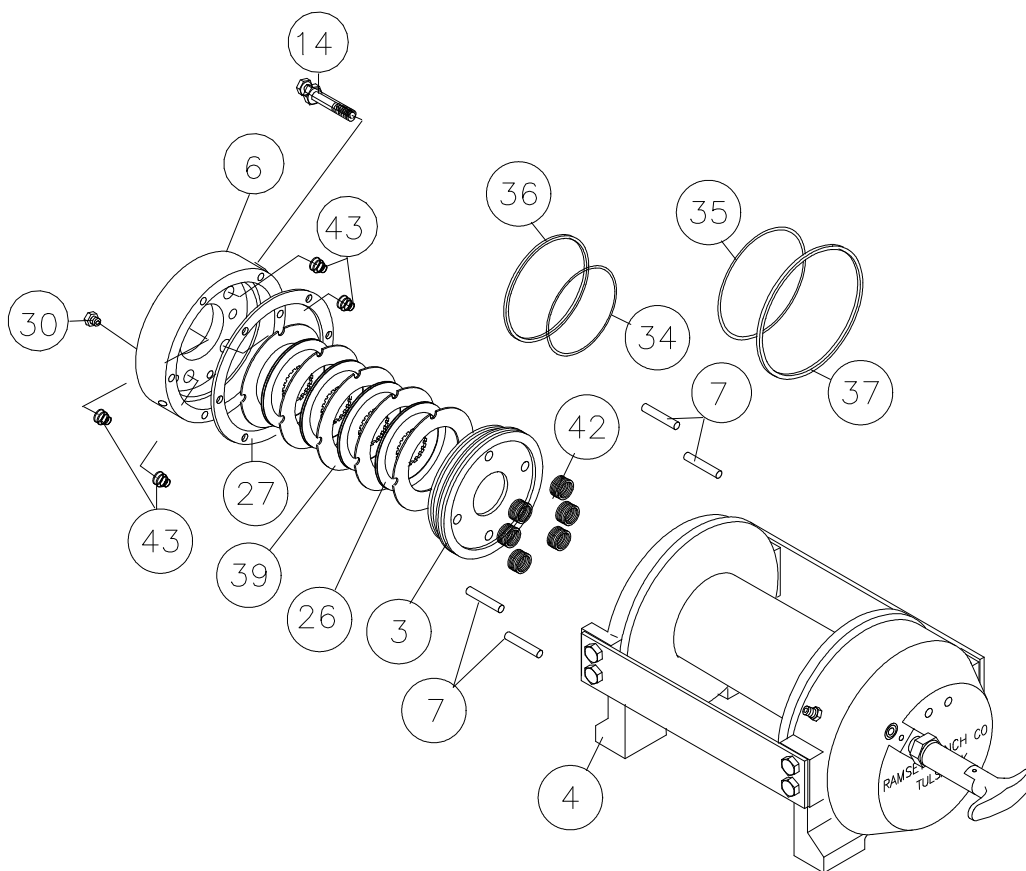

Remove tie plates (item #9) from end bearings (items #4 & #5) by unscrewing capscrews (item #16), as shown. Remove snap ring (item #41) and thrust washer (item #48) from shaft. Slide motor end bearing (item #4) from drum (item #1) and drum from gear housing end bearing (item #5).

Remove input shaft (item #8) and thrust washer (item #47) from end bearing. Inspect gear teeth and splined end of shaft for signs of wear. If damaged, it will be necessary to replace shaft.

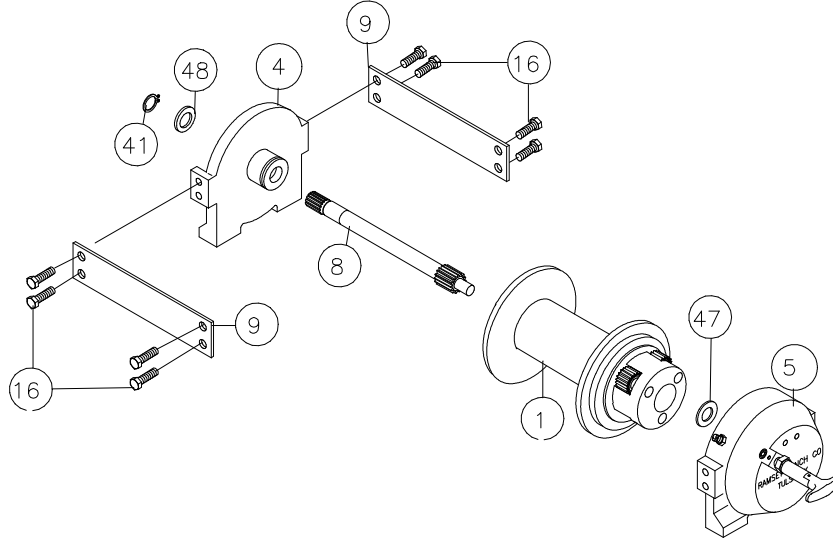

Remove o-ring (item #32), bushing (item #12) from outside of motor end bearing (item #4), remove o-ring (item #33), bearing (item #11) from inside of motor end bearing (item #4). Place new, well oiled, o-ring (item #33) into groove inside of end bearing and press new bearing (item #11) into end bearing. Press bushing (item #12) onto end bearing and dip o-ring (item #32) in oil and seat into groove of end bearing.

Remove seal (item #40) from gear housing end bearing (item #5). Loosen nut (item #21) and remove nylon setscrew (item #18) and remove ring gear (item #29) from gear housing end bearing, if necessary. Remove bushing (item #13) and bearing (item #10) from gear housing end bearing (item #5). Press new bushing (item #13) and bearing (item #10) into place in end bearing. Install ring gear and nylon setscrew and nut. Ring gear must be fully seated in gear housing end bearing (item #5) and slot in ring gear must NOT be aligned with clutch shifter hole. Install new seal in gear housing end bearing, with sharp edge of seal outward.

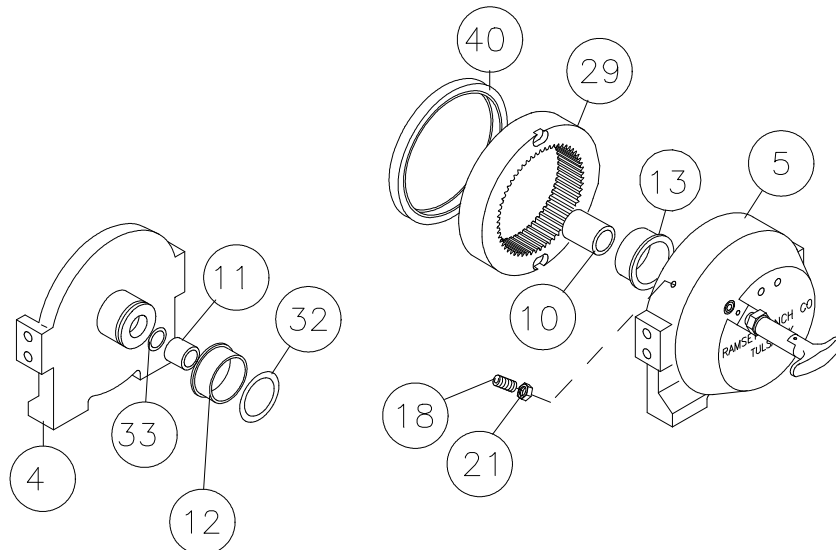

Generously apply grease (MOBILITH SHC 007) to teeth of ring gear (item #28), teeth of planet gears in drum (item #1) and to bushing in gear housing end bearing (item #5). Apply a small amount of grease to base of bushing on motor end bearing (item #4). Apply grease to teeth of gear and short end of shaft (item #8). Place gear end of shaft through thrust washer (item #47) and into bearing in end bearing (item #5). Place drum over shaft and rotate drum to engage planet gears with output gear on shaft and with ring gear in end bearing.

Assemble end bearing (item #4) to drum assembly and use tie plates (item #9) and capscrews (item #16) to hold both end bearings together. Tighten capscrews to 55 Ft. Lbs. (75 Nm.). Slide thrust washer (item #48) over end of shaft and against end bearing (item #4). Place snap ring (item #41) into groove in splined end of shaft.

If necessary, remove and replace appropriate shifter assembly (item #2 or #3), as follows:

MANUAL CLUTCH SHIFTER ASSEMBLY

Remove by loosening setscrew (item #18), jam nut and unscrewing clutch shifter. Be sure slot in ring gear is not aligned with clutch shifter hole. Rotate drum, if necessary, to insure hole and slot are not aligned. Reinstall clutch shifter with plunger, jam nut and handle positioned in cylinder housing, as shown. Thread assembly (with handle engaged in cylinder slot) into the end bearing. Pull drum toward the brake housing end bearing to remove play. Hold drum in the position and continue threading the shifter assembly in until the gap between the end of the handle and cylinder is $7/16^{+0} -1/16$ inch and handle is in the horizontal position, as shown below. NOTE: This gap will vary with drum endplay. With the drum pulled against the gear housing, the gap should be $3/8$ inch. Lightly tighten jam nut. Rotate drum until handle snaps fully into the engaged position. Pull handle out and rotate 90° . Verify that drum can be rotated freely (at least one full revolution) with clutch shifter at DISENGAGED position. Securely tighten jam nut while holding the handle. Tighten setscrew securely. Re-check clutch operation as described on page 5.

AIR CYLINDER SHIFTER ASSEMBLY

Remove by loosening setscrew (item #18), jam nut and unscrewing clutch shifter. To reinstall, thread air cylinder into housing. Install one or two shims (item #45) under cylinder head, if needed, to orient air cylinder port for pneumatic connections. Tighten setscrew. Refer to page 5 and check for proper operation of the clutch.

BLOCKED CLUTCH

Insert plunger into gear housing bore so it engages into ring gear slot. Pull drum flange toward gear housing and thread setscrew into housing until it bottoms out and drum starts to move. Back setscrew out $1/2$ turn and lock in place with jam nut.

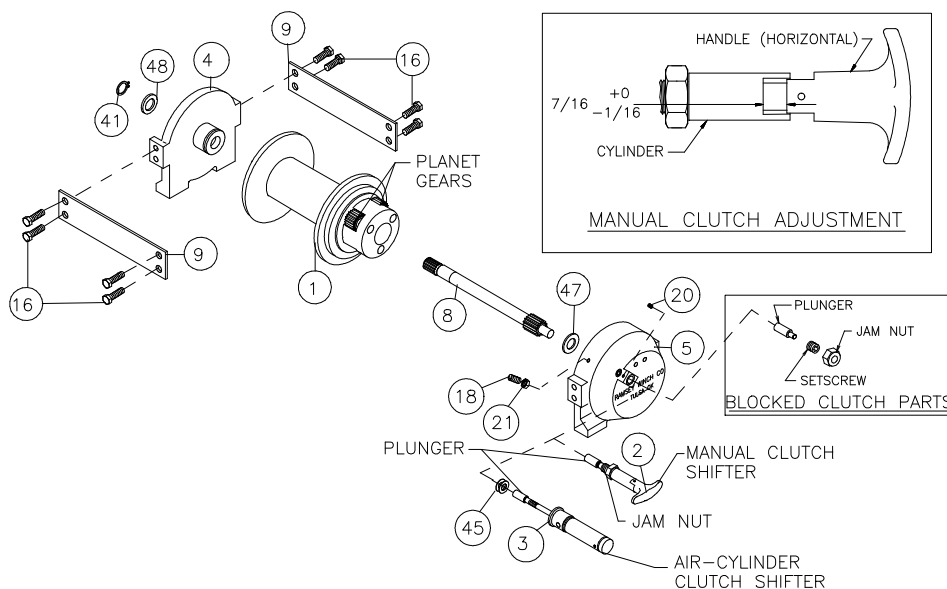

Set winch on gear housing end with motor end bearing (item #4) up. Insert (6) springs (item #42) into pockets of motor end bearing (item #4), as shown, leaving top and bottom pockets empty. Install coupling (item #23) over splined end of shaft (item #8). Put (4) brake pins (item #7) into (4) holes in motor end bearing. Install well-oiled o-ring (items #34 & #35) and backup rings (items #36 & #37) into grooves in O.D. of piston (item #3). Place o-rings into portions of grooves nearest to center of piston in both cases. See SECTION A-A below.

Piston (item #3), brake disc (item #26) and separator plates (item #39) must be clean and free of grease and oil. Place piston over pins (item #7) and on top of springs (item #42). Place separator plates (item #39) and brake disc alternately on top of piston, as shown below. Press larger diameter end of (4) springs (item #43) into pockets in brake housing (item #6). Place gasket (item #27) on top of end bearing (item #4). Place brake housing over brake parts with fitting ports downward toward mounting feet. Align mounting holes and force brake housing down onto end bearing (item #4). Apply 271 Loc-tite to 6 capscrews (item #14) and finger tighten until flush with surface of brake housing. Torque capscrews (2 turns each) in a criss-cross pattern until a torque of 30 ft. lbs., per capscrew, is achieved.

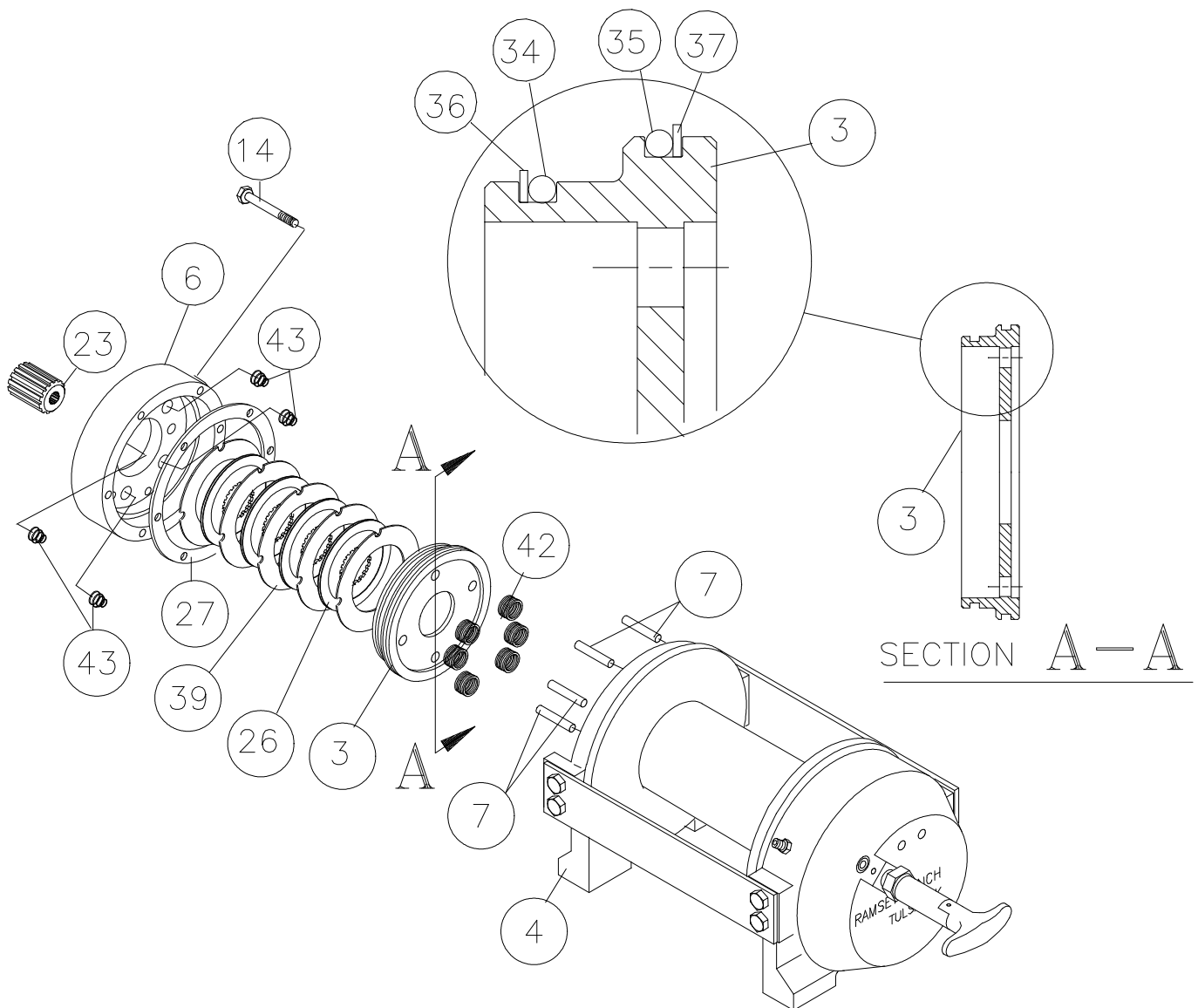

Place gasket (item #28) into position on mounting surface of motor (item #31). Slide motor shaft into coupling and attach motor to brake housing (item #6). Use (2) capscrews (item #15) with lockwashers (item #22) and torque to 87 ft. lbs. (118 Nm) each. Securely connect tube (item #44) to elbows (item #24) in valve (item #45) and in bottom of brake housing (item #6).

Apply at least 550 PSI hydraulic system pressure to release brake and verify that brake releases, by observing that the winch drum rotates.

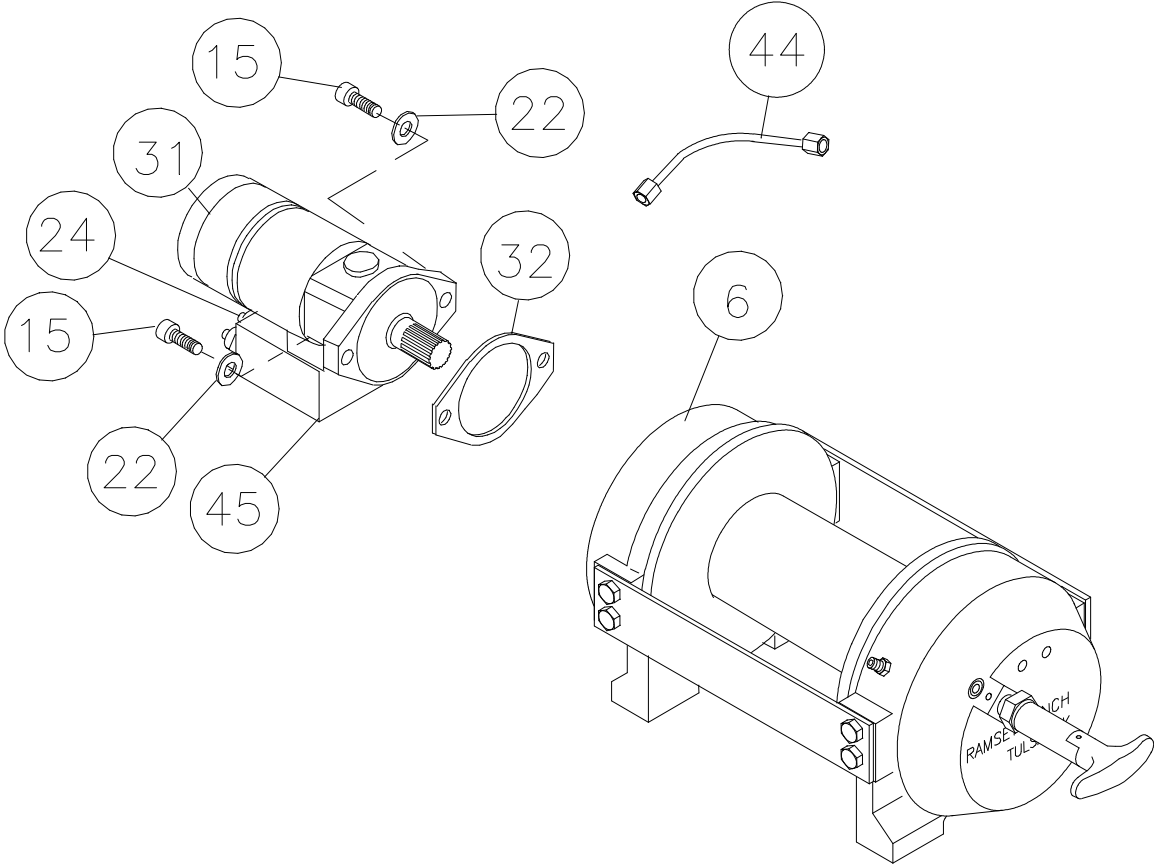

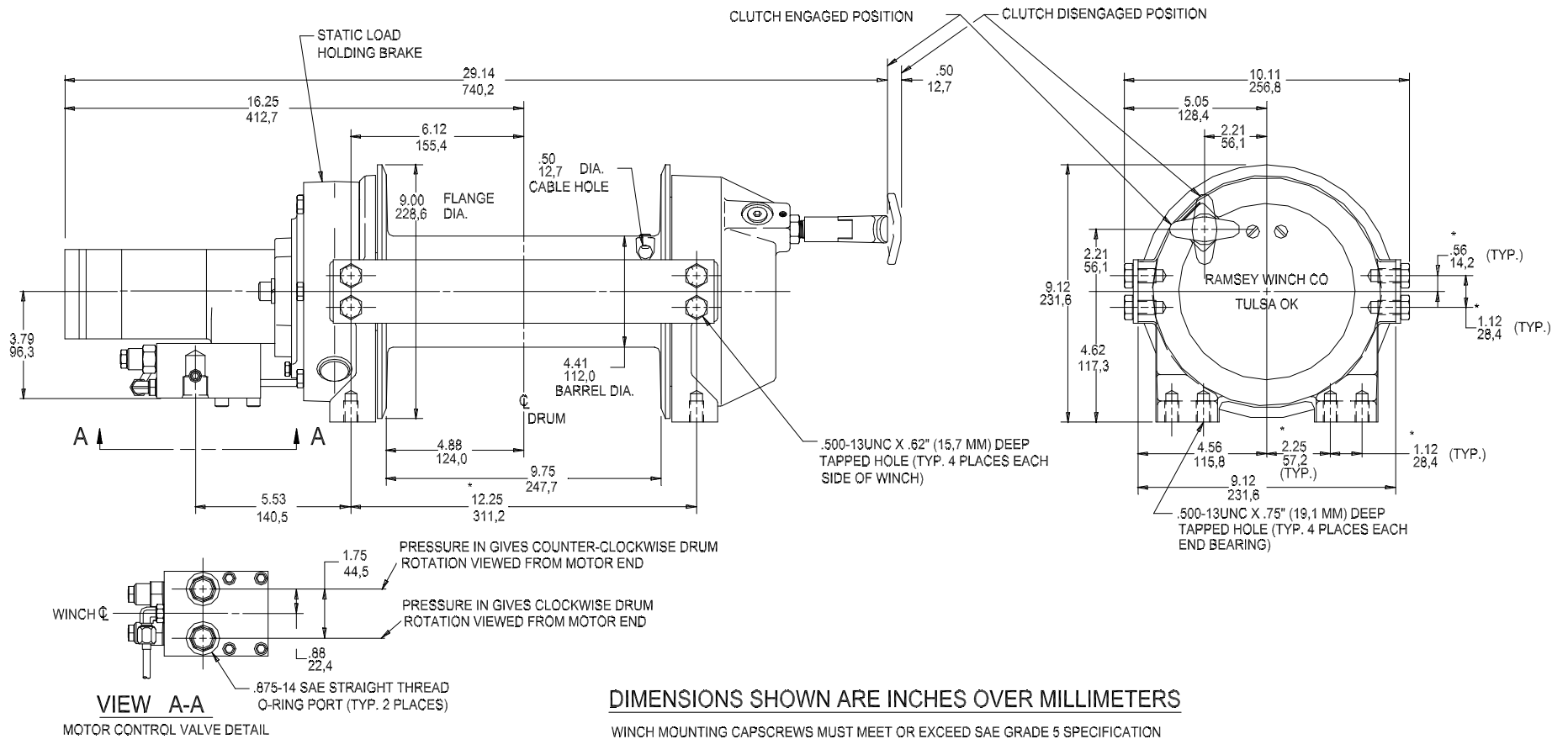

DIMENSIONS SHOWN ARE INCHES OVER MILLIMETERS

WINCH MOUNTING CAPSCREWS MUST MEET OR EXCEED SAE GRADE 5 SPECIFICATION

*NOTE: THESE HOLE LOCATIONS MUST BE HELD WITHIN ±.03" (0,8 MM) OF TRUE POSITION. RECOMMENDED MOUNTING HOLE DIAMETER IS .53" (13,5 MM).

MODEL RPH-12,000T

WITH MANUAL CLUTCH SHIFTER

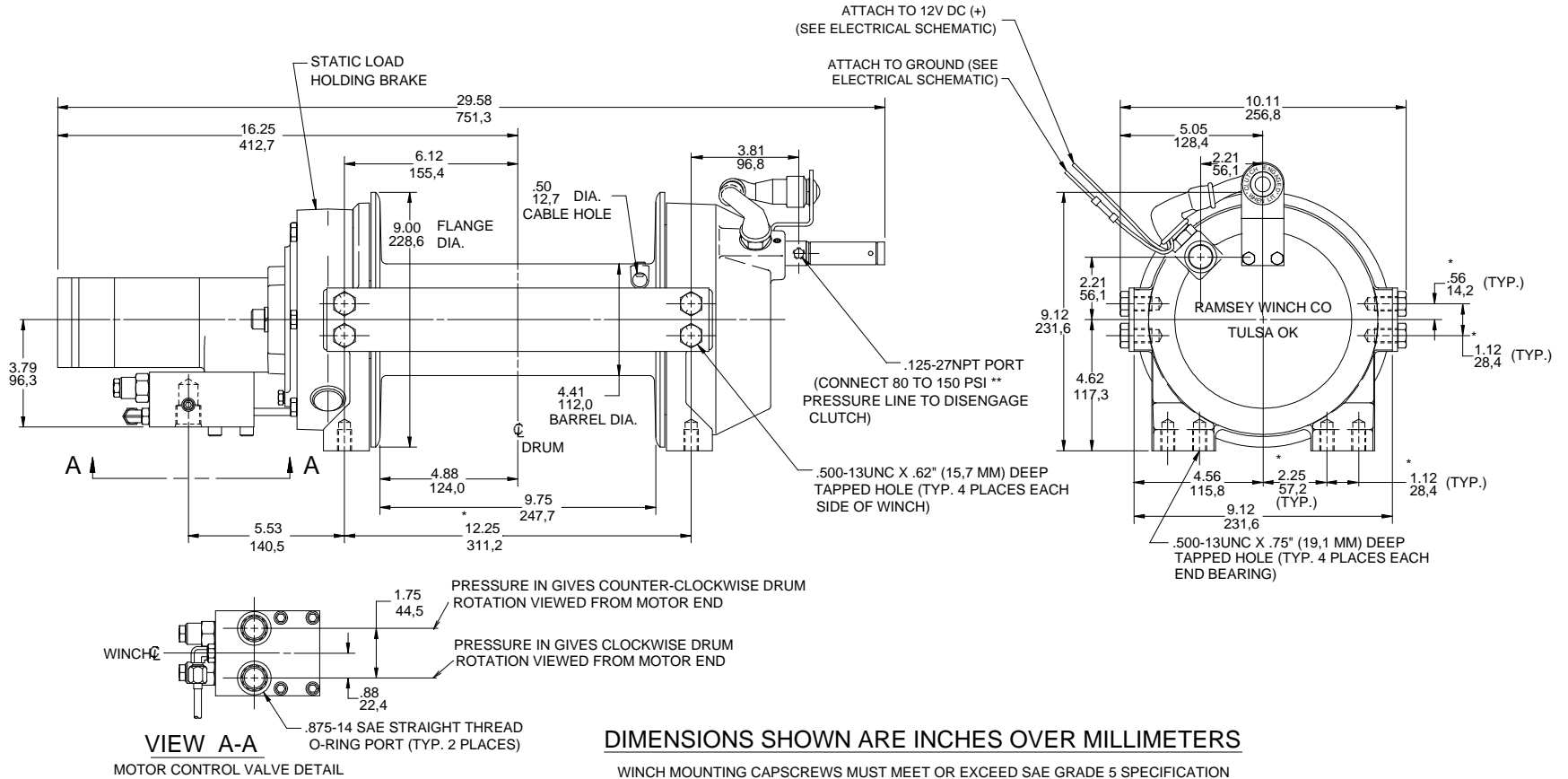

DIMENSIONS SHOWN ARE INCHES OVER MILLIMETERS

WINCH MOUNTING CAPSCREWS MUST MEET OR EXCEED SAE GRADE 5 SPECIFICATION

*NOTE: THESE HOLE LOCATIONS MUST BE HELD WITHIN ±.03" (0,8 MM) OF TRUE POSITION. RECOMMENDED MOUNTING HOLE DIAMETER IS .53" (13,5 MM).

** CAUTION: PRESSURE MUST NOT EXCEED 150 PSI.

MODEL RPH-12,000T

WITH AIR CYLINDER CLUTCH SHIFTER

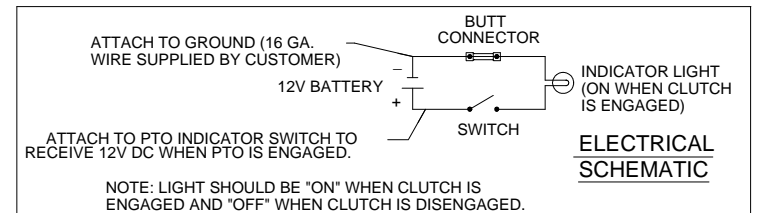

NOTES

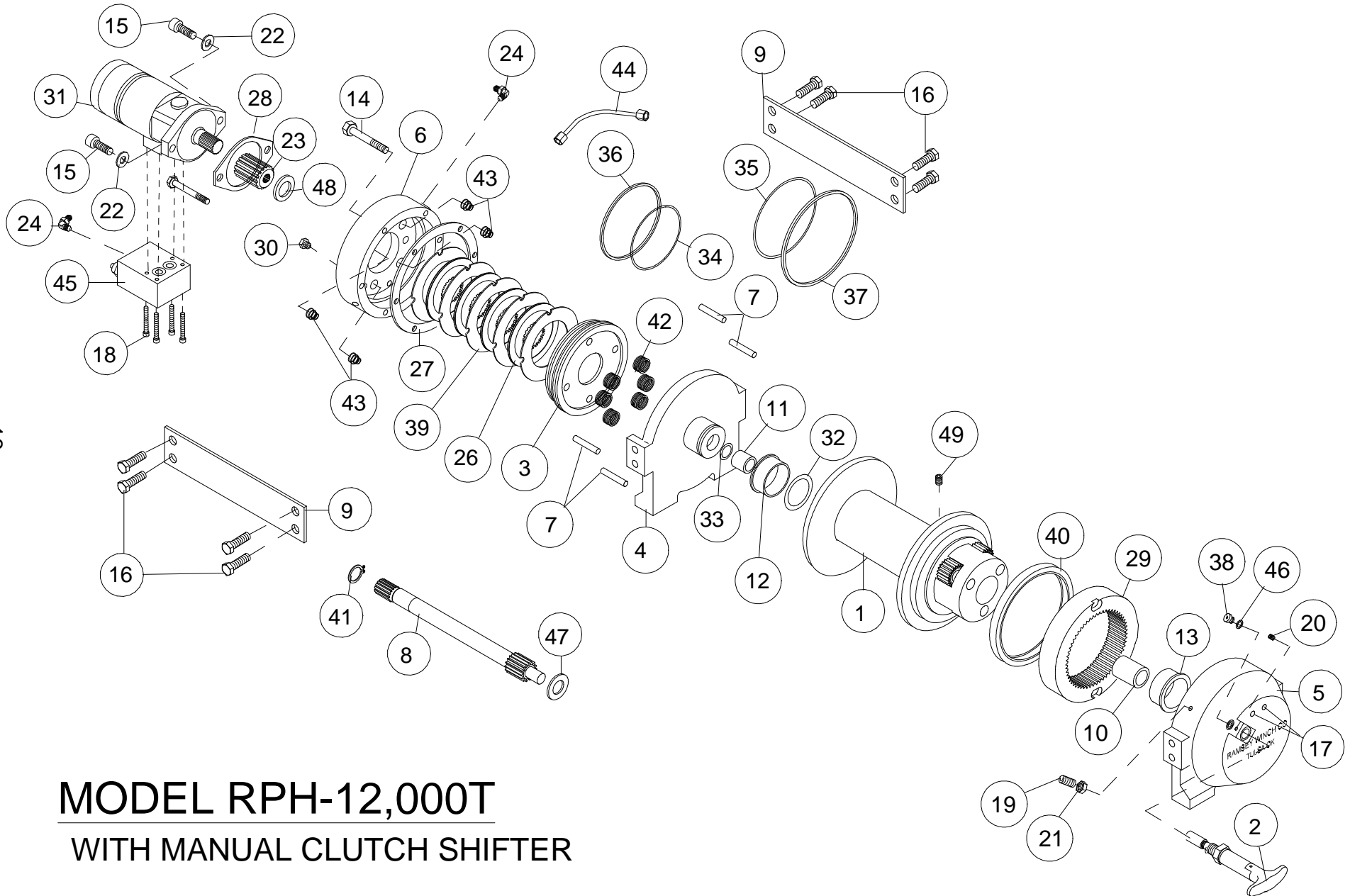

MODEL RPH-12,000T
WITH MANUAL CLUTCH SHIFTER

PARTS LIST RPH 12,000T WITH MANUAL CLUTCH SHIFTER

<u>ITEM</u>	<u>QTY.</u>	<u>PART NO.</u>	<u>DESCRIPTION</u>
1	1	93758	DRUM ASS'Y.
2	1	276052	SHIFTER ASS'Y.-MANUAL
3	1	306042	PISTON-BRAKE
4	1	338300	END BEARING-MOTOR
5	1	338301	END BEARING-GEAR HOUSING
6	1	338302	HOUSING-BRAKE
7	4	346045	PIN-BRAKE
8	1	357504	SHAFT-INPUT/SUN GEAR
9	2	395172	TIE PLATE
10	1	402120	BEARING-GEAR HSG.
11	1	402121	BEARING-MTR. END BEARING
12	1	412084	BUSHING-DRUM (MTR. END)
13	1	412085	BUSHING-DRUM (G.HSG. END)
14	6	414303	CAPSCREW-3/8-16NC X 2-1/2 LG. HX.HD., GR. 5 PLTD.
15	2	414948	CAPSCREW 1/2-13NC X 1-1/4 LG. SOC.HD.
16	8	414581	CAPSCREW 1/2-13NC X 3/4 LG. HX.HD. GR.5 PLTD.
17	2	414854	CAPSCREW 1/4-20NC X 1/2 LG. RD.HD. SLOT PLTD.
18	4	414868	CAPSCREW 5/16-18NC X 1-1/2 LG. SOC. HD. NYLOK
19	1	414926	SETSCREW-3/8-16NC X 1 LG., SOCKET, NYLON
20	1	416016	SETSCREW-1/4-20NC X 1/4 LG., HX. SOC. HD.
21	1	418036	NUT 3/8-16NC HEX. JAM
22	2	418218	LOCKWASHER-1/2 ID MED. SECT.
23	1	431015	COUPLING-MOTOR
24	2	432018	FITTING-7/16 ELBOW
25			NOT USED
26	4	438022	DISC-BRAKE
27	1	442220	GASKET-BRAKE
28	1	442223	GASKET-MOTOR
29	1	444085	GEAR-RING
30	1	456038	FITTING-VENT
31	1	458090	MOTOR-HYDRAULIC
32	1	462046	O-RING (DRUM)
33	1	462056	O-RING
34	1	462057	O-RING
35	1	462058	O-RING
36	1	462059	O-RING BACKUP
37	1	462060	O-RING BACKUP
38	1	472052	PLUG
39	5	474111	PLATE-SEPARATOR
40	1	486080	SEAL-GEAR HSG.
41	1	490037	SNAP RING
42	6	494110	SPRING-BRAKE
43	4	494112	SPRING
44	1	509009	TUBE ASSEMBLY
45	1	516013	VALVE-MOTOR CONTROL
46	1	518037	THRUST WASHER
47	1	518047	THRUST WASHER
48	1	518052	THRUST WASHER
49	1	416059	SETSCREW-3/8-16NC X 1/2 HX SOC HD CUP

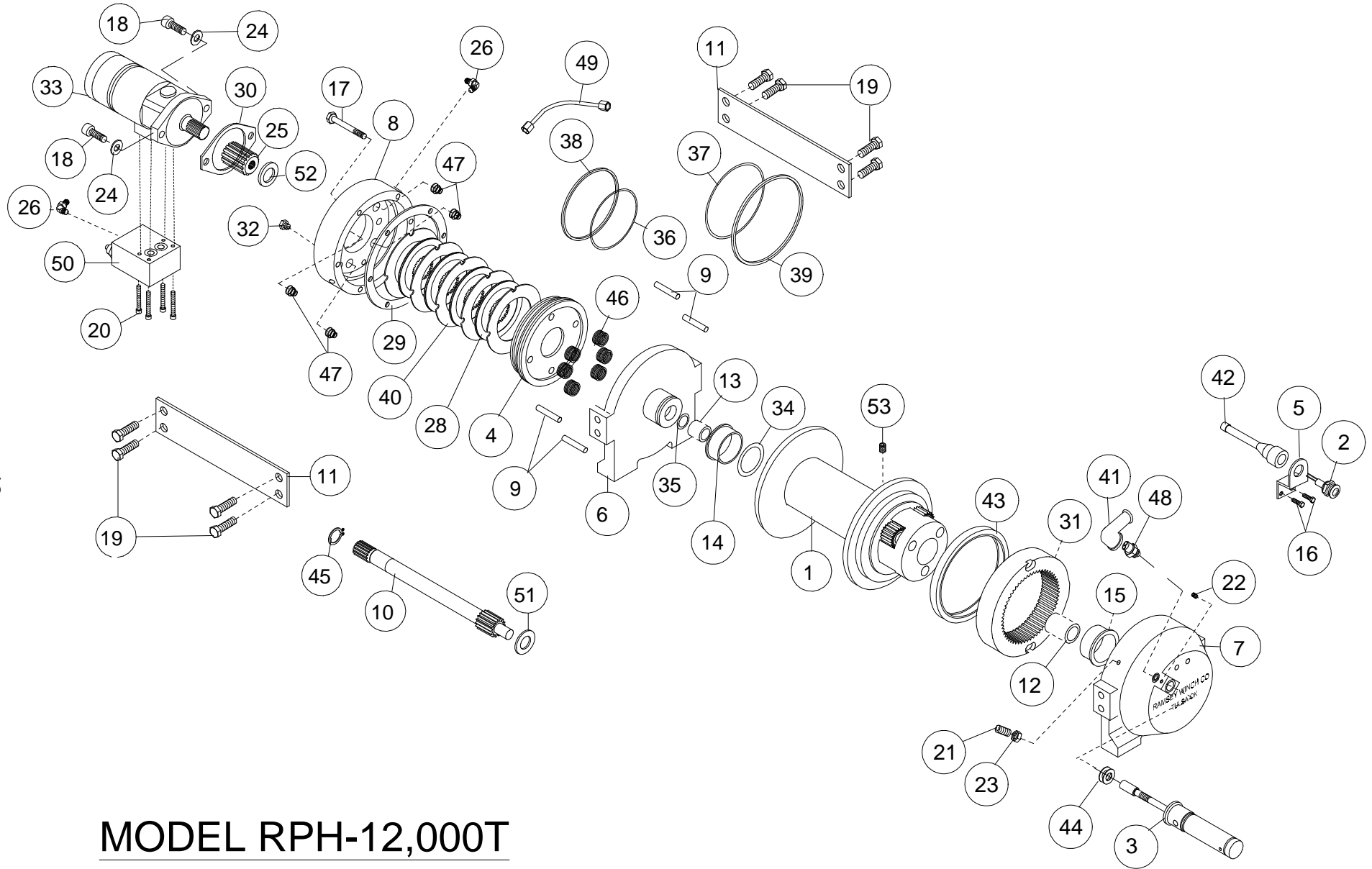

MODEL RPH-12,000T
 WITH AIR CYLINDER CLUTCH SHIFTER

PARTS LIST RPH 12,000T WITH AIR-CYLINDER CLUTCH SHIFTER

<u>ITEM</u>	<u>QTY.</u>	<u>PART NO.</u>	<u>DESCRIPTION</u>
1	1	93758	DRUM ASS'Y.
2	1	236020	LIGHT ASSEMBLY
3	1	276053	SHIFTER ASS'Y.-AIR CYLINDER
4	1	306042	PISTON-BRAKE
5	1	312529	BRACKET-LIGHT
6	1	338300	END BEARING-MOTOR
7	1	338301	END BEARING-GEAR HOUSING
8	1	338302	HOUSING-BRAKE
9	4	346045	PIN-BRAKE
10	1	357504	SHAFT-INPUT/SUN GEAR
11	2	395172	TIE PLATE
12	1	402120	BEARING-GEAR HSG.
13	1	402121	BEARING-MTR. END BEARING
14	1	412084	BUSHING-DRUM (MTR. END)
15	1	412085	BUSHING-DRUM (G.HSG. END)
16	2	414036	CAPSCREW 1/4-20NC X 1/2 LG.
17	6	414303	CAPSCREW 3/8-16NC X 2-1/2 LG. HX.HD., GR. 5 PLTD.
18	2	414948	CAPSCREW 1/2-13NC X 1-1/4 LG. SOC.HD.
19	8	414581	CAPSCREW 1/2-13NC X 3/4 LG. HX.HD. GR.5 PLTD.
20	4	414868	CAPSCREW 5/16-18NC X 1-1/2 LG. SOC. HD. NYLOK
21	1	414926	SETSCREW-3/8-16NC X 1 LG., SOCKET, NYLON
22	1	416016	SETSCREW-1/4-20NC X 1/4 LG., HX. SOC. HD.
23	1	418036	NUT 3/8-16NC HEX. JAM
24	2	418218	LOCKWASHER-1/2 ID MED. SECT.
25	1	431015	COUPLING-MOTOR
26	2	432018	FITTING-7/16 ELBOW
27			NOT USED
28	4	438022	DISC-BRAKE
29	1	442220	GASKET-BRAKE
30	1	442223	GASKET-MOTOR
31	1	444085	GEAR-RING
32	1	456038	FITTING-VENT
33	1	458090	MOTOR-HYDRAULIC
34	1	462046	O-RING (DRUM)
35	1	462056	O-RING
36	1	462057	O-RING
37	1	462058	O-RING
38	1	462059	O-RING BACKUP
39	1	462060	O-RING BACKUP
40	5	474111	PLATE-SEPARATOR
41	1	482013	BOOT
42	1	482045	BOOT
43	1	486080	SEAL-GEAR HSG.
44	2	488007	SHIM
45	1	490037	SNAP RING
46	6	494110	SPRING-BRAKE
47	4	494112	SPRING
48	1	504021	SWITCH
49	1	509009	TUBE ASSEMBLY
50	1	516013	VALVE-MOTOR CONTROL
51	1	518047	THRUST WASHER
52	1	518052	THRUST WASHER
53	1	416059	SETSCREW-3/8-16NC X 1/2 HX SOC HD CUP

PARTS LIST RPH 12,000T WITH BLOCKED CLUTCH

ITEM	QTY.	PART NO.	DESCRIPTION
1	1	93758	DRUM ASS'Y.
2	1	306042	PISTON-BRAKE
3	1	338300	END BEARING-MOTOR
4	1	338301	END BEARING-GEAR HOUSING
5	1	338302	HOUSING-BRAKE
6	4	346045	PIN-BRAKE
7	1	357504	SHAFT-INPUT/SUN GEAR
8	2	395172	TIE PLATE
9	1	402120	BEARING-GEAR HSG.
10	1	402121	BEARING-MTR. END BEARING
11	1	412084	BUSHING-DRUM (MTR. END)
12	1	412085	BUSHING-DRUM (G.HSG. END)
13	6	414303	CAPSCREW-3/8-16NC X 2-1/2 LG. HX.HD., GR. 5 PLTD.
14	2	414948	CAPSCREW 1/2-13NC X 1-1/4 LG. SOC.HD.
15	8	414581	CAPSCREW 1/2-13NC X 3/4 LG. HX.HD. GR.5 PLTD.
16	2	414854	CAPSCREW 1/4-20NC X 1/2 RD.HD. SLOT PLTD.
17	4	414868	CAPSCREW 5/16-18NC X 1-1/2 LG. SOC. HD. NYLOK
18	1	414926	SETSCREW-3/8-16NC X 1 LG., SOCKET, NYLON
19	1	416016	SETSCREW-1/4-20NC X 1/4 LG., HX. SOC. HD.
20	1	416080	SETSCREW 5/8-18NF X 1 LG. HX.SOC.HD.
21	1	418036	NUT 3/8-16NC HEX. JAM
22	1	418088	NUT 5/8-18NF
23	2	418218	LOCKWASHER-1/2 ID MED. SECT.
24	1	426048	PLUNGER
25	1	431015	COUPLING-MOTOR
26	2	432018	FITTING-7/16 ELBOW
27			NOT USED
28	4	438022	DISC-BRAKE
29	1	442220	GASKET-BRAKE
30	1	442223	GASKET-MOTOR
31	1	444085	GEAR-RING
32	1	456038	FITTING-VENT
33	1	458090	MOTOR-HYDRAULIC
34	1	462046	O-RING (DRUM)
35	1	462056	O-RING
36	1	462057	O-RING
37	1	462058	O-RING
38	1	462059	O-RING BACKUP
39	1	462060	O-RING BACKUP
40	1	472052	PLUG
41	5	474111	PLATE-SEPARATOR
42	1	486080	SEAL-GEAR HSG.
43	1	490037	SNAP RING
44	6	494110	SPRING-BRAKE
45	4	494112	SPRING
46	1	509009	TUBE ASSEMBLY
47	1	516013	VALVE-MOTOR CONTROL
48	1	518037	THRUST WASHER
49	1	518047	THRUST WASHER
50	1	518052	THRUST WASHER
51	1	416059	SETSCREW-3/8-16NC X 1/2 HX SOC HD CUP

LIMITED WARRANTY

RAMSEY WINCH warrants each new RAMSEY Winch to be free from defects in material and workmanship for a period of one (1) year from date of purchase.

The obligation under this warranty, statutory or otherwise, is limited to the replacement or repair at the Manufacturer's factory, or at a point designated by the Manufacturer, of such part that shall appear to the Manufacturer, upon inspection of such part, to have been defective in material or workmanship.

This warranty does not obligate RAMSEY WINCH to bear the cost of labor or transportation charges in connection with the replacement or repair of defective parts, nor shall it apply to a product upon which repair or alterations have been made, unless authorized by Manufacturer, or for equipment misused, neglected or which has not been installed correctly.

RAMSEY WINCH shall in no event be liable for special or consequential damages. RAMSEY WINCH makes no warranty in respect to accessories such as being subject to the warranties of their respective manufacturers.

RAMSEY WINCH, whose policy is one of continuous improvement, reserves the right to improve its products through changes in design or materials as it may deem desirable without being obligated to incorporate such changes in products of prior manufacture.

If field service at the request of the Buyer is rendered and the fault is found not to be with RAMSEY WINCH's product, the Buyer shall pay the time and expense to the field representative. Bills for service, labor or other expenses that have been incurred by the Buyer without approval or authorization by RAMSEY WINCH will not be accepted

See warranty card for details.



316 West Milwaukee, PO Box 511
New Hampton, IA 50659
P: (800)222-6047 | F: (641)394-4044
E: zips@zips.com | W: Zips.com