

DDR05

Rear suspension package Ensemble pour suspension arrière Ensemble para suspensión de trasero

INSTALLATION INSTRUCTIONS

- Raise vehicle allowing the axle to hang freely.
- Remove existing bump stop assembly and retain fasteners.
- Assemble Aeon rubber spring and bracket as shown in the adjacent diagram.
- Mount Timbren assembly using OEM fasteners.
- Clamp Timbren bottom support onto axle using fasteners provided. Torque U-bolt nuts to 30 - 35 ft.lb.
- Lower vehicle.

NOTES:

Check that brake line or brake cable locations do not interfere with Aeon spring.
Use rubber washer #3 and bolt #6 to achieve desired ride height.
When removing OEM fasteners, use penetrating fluid.

Do not exceed vehicle manufacturer's recommended axle weight rating. Check for AEON® interference with vehicle components - Under load AEON® will "expand" in diameter.

INSTRUCTIONS DE MONTAGE

- Soulever le véhicule de sorte que l'essieu soit dégagé.
- Retirer l'assemblage de la butée de suspension existante et conserver la boulonnerie.
- Assembler le ressort en caoutchouc Aeon et le support comme il est indiqué dans le schéma adjacent.
- Monter l'assemblage Timbren en utilisant les trous existants et la boulonnerie fournie avec l'assemblage Timbren.
- Attacher le support inférieur Timbren sur l'essieu en utilisant la boulonnerie fournie. Serrer les écrous des boulons en U à 30 - 35 ft. lb.
- Redescendre le véhicule.

REMARQUES:

Vérifier que les emplacements de la conduite de frein et du câble de frein ne nuisent pas au ressort Aeon.
Utiliser la rondelle en caoutchouc no 3 et fixer à l'aide de boulons la rondelle en caoutchouc no 6 pour obtenir le niveau du véhicule désiré.
Utiliser un fluide pénétrant, au moment de retirer la boulonnerie du fabricant d'équipement.

Ne pas dépasser le poids nominal sur l'essieu recommandé par le fabricant du véhicule. Vérifier que le ressort AEON® n'a pas d'incidence sur d'autres pièces du véhicule - Le ressort AEON® augmentera son diamètre avec la charge.

INSTRUCCIONES DE INSTALACIÓN

- Levante el vehículo dejando que los ejes cuelguen libremente.
- Retire la unidad del tope de suspensión existente.
- Ensamble el resorte de caucho Aeon y la abrazadera como se muestra en el diagrama adyacente.
- Monte la unidad Timbren utilizando los orificios existentes y los elementos de sujeción Timbren provistos.
- Sujete con abrazaderas el soporte inferior Timbren al eje utilizando los elementos de sujeción provistos. Apretar las tuercas de los pernos en U para 30 - 35 ft. lb.
- Baje el vehículo.

NOTAS:

Verifique que la ubicación de la tubería de freno o del cable del freno no interfiera con el resorte Aeon.
Use arandela de caucho #3 y perno #6 para lograr el nivel deseado del vehículo.
Al remover los elementos de sujeción del fabricante original de equipo, utilice fluido penetrante.

No exceda la carga nominal en el eje recomendada por el fabricante del vehículo. Compruebe que no haya interferencia entre el resorte AEON® y los otros componentes del vehículo. Bajo carga, el resorte AEON® se ampliará en diámetro.

Ref. = Reference = No. de référence = Núm. de referencia
Part = Part #. = No. de pièce = Núm. de pieza
Qty. = Quantity = Quantité = Cantidad

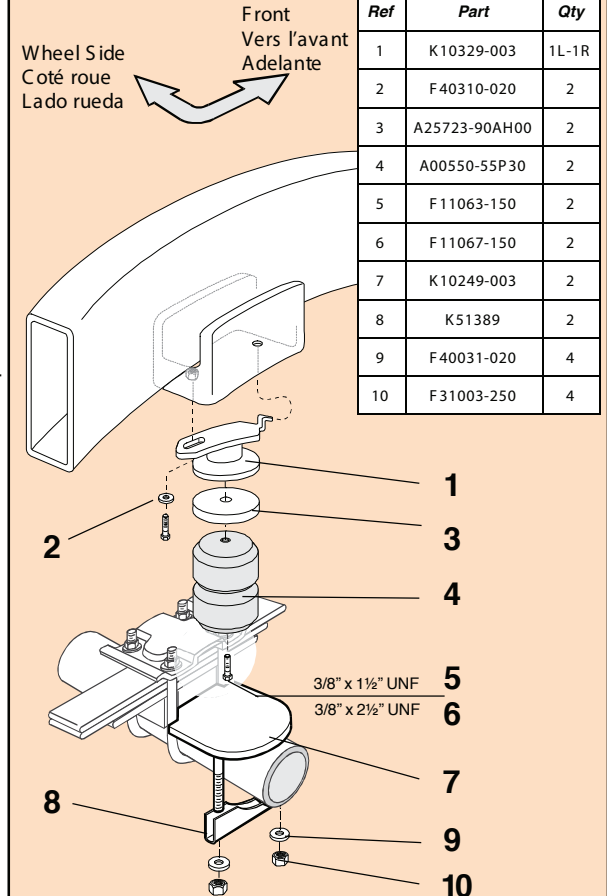

Ref	Part	Qty
1	K10329-003	1L-1R
2	F40310-020	2
3	A25723-90AH00	2
4	A00550-55P30	2
5	F11063-150	2
6	F11067-150	2
7	K10249-003	2
8	K51389	2
9	F40031-020	4
10	F31003-250	4

DDR05

PART NUMBER	DESCRIPTION	QTY	LOCATION
F31003-250	NYLOCK LOCKNUT 3/8 UNC GR 5 Z	4	G1B
F40031-020	WASHER FLAT USS 3/8 x 1 GR 2 Z	4	G1C
F11063-150	HCS 3/8 x 1-1/2 UNF GR 5 Z	2	G1C
F11067-150	HCS 3/8 x 2-1/2 UNF GR 5 Z	2	G2C
F40310-020	WASHER FLAT M10 GR 4.6 Z	2	I1D

A00550-55P30	AEON 550-55 ASSEMBLY P+W3/8	2	C11B
A25723-90AH00	RUBBER SPACER 4"od x 1" thk w/ AH Bushing	2	

K10329LH-003	DDR00/DDR05/DDR052 WELDMENT LH PTD.	1	D1A
K10329RH-003	DDR00/DDR05/DDR052 WELDMENT RH PTD.	1	D1A
K10249-003	DR1525H2 / DDR05 WELDMENT PAINTED	2	D2C
K51389	SADDLE CLAMP 3-1/2"	2	G5B

B90201-CR	LARGE REAR BOX 10.5 x 8.5 x 6	1	A--D
B10000	8" x 12" BUBBLE FOR KITS	1	
B00029-010	BARCODE LABEL FOR KIT	1	

Issued: 10/6/2016

Clearance Instructions:

Rear SES Kits for Pick-Ups and Vans should have a 1/2" to 1-1/2" gap between the rubber spring and contact point when empty.

A partial load, or vehicle accessories will reduce or eliminate the gap.

Front SES kits are usually in full contact.

Medium and Heavy-Duty Trucks, Trailers and Motorhomes will be in constant contact, and have no gap.

Lifetime Warranty:

Timbren SES Kits are warranted against defects in material and workmanship, under normal use and service, for the life of the vehicle on which the kit was originally installed. The warranty is not transferable and proof of purchase is required. The warranty is limited to the replacement of the failed part.

TIMBREN will not be responsible for any labour or freight charges involved in the replacement of any product. TIMBREN shall be entitled to make its own inspection to determine the validity of the claim. TIMBREN shall not be liable nor warranty the product in the event of alteration, misuse, overload, negligence or damage caused by others.

If ride or performance of our product is unsatisfactory in any way, please call: 1-800-263-3113 or email sales@timbren.com

ASSEMBLY NOTES:

APPLY 'LEFT' LABEL TO L/H BRACKET